

Fuse 1

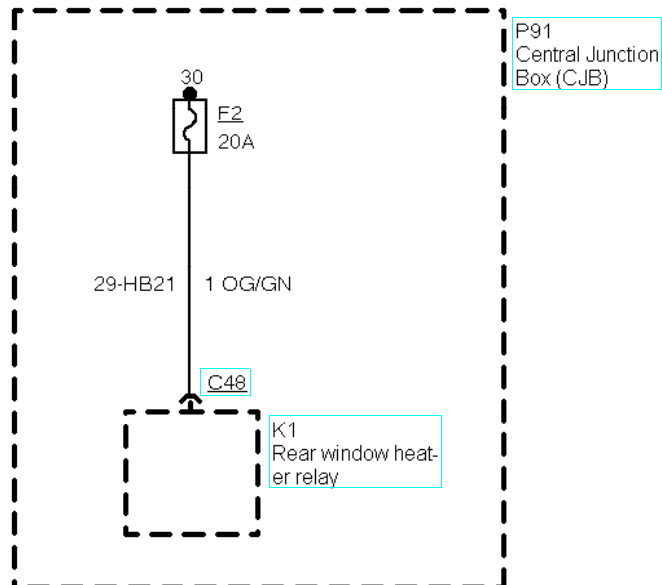

---

Fuse 2, before 01/97



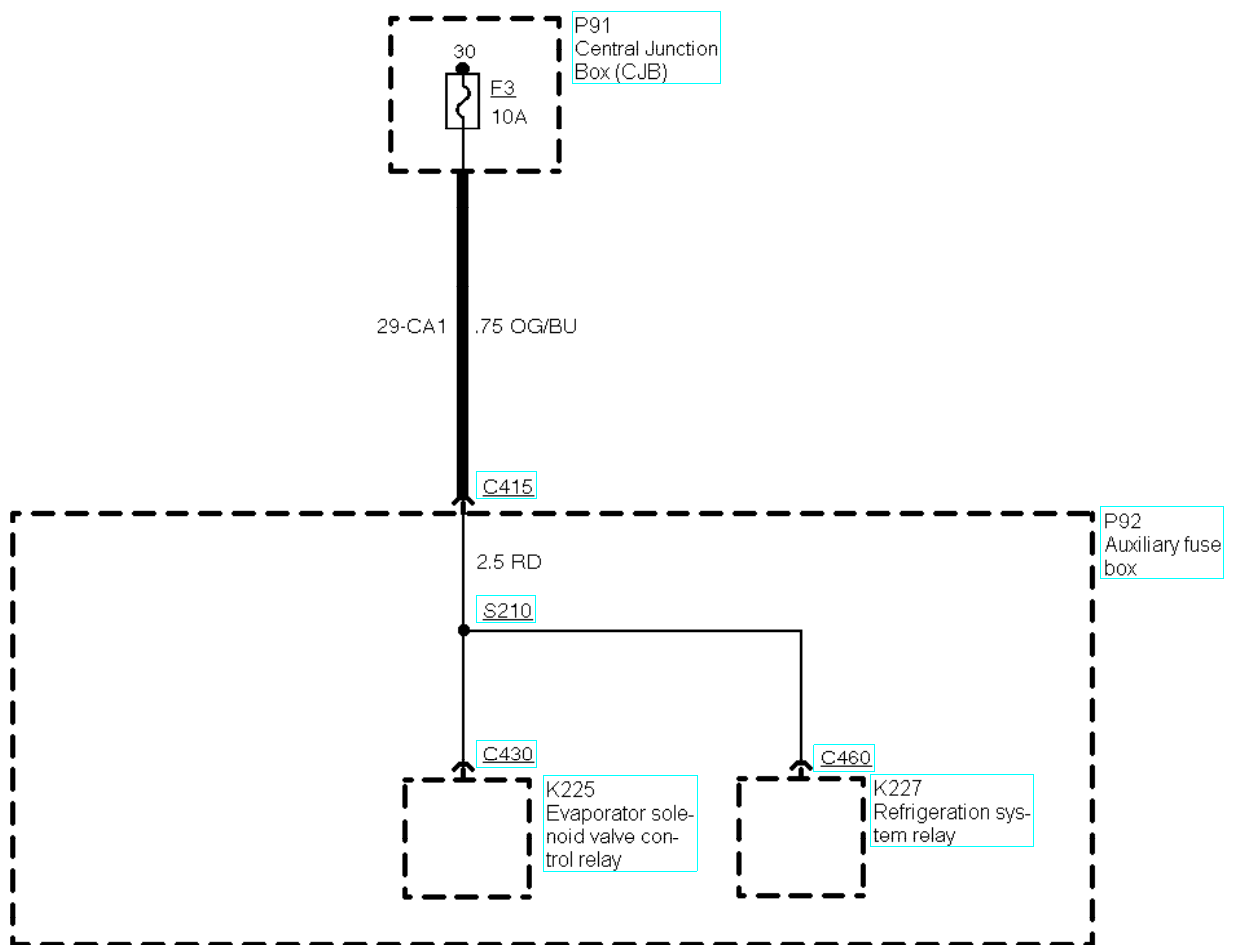

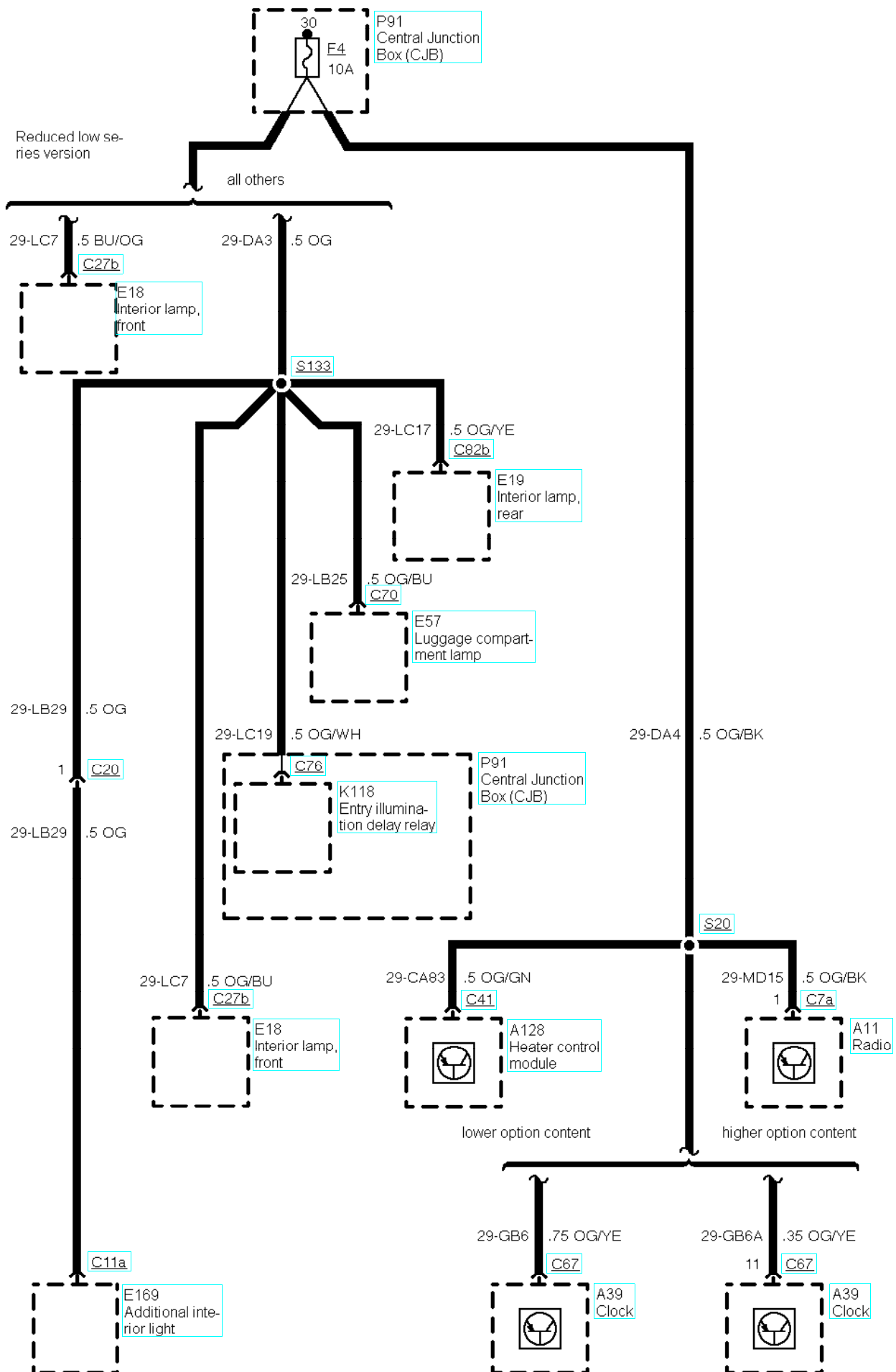

Fuse 4, as of 01/97

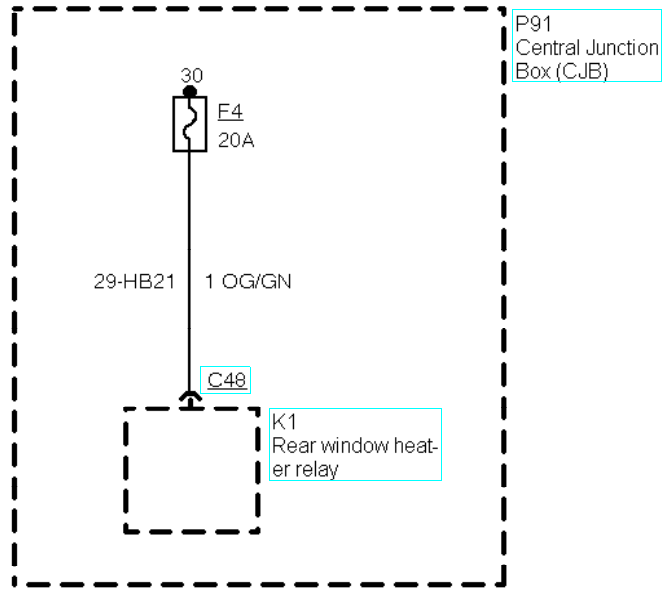

Fuse 5

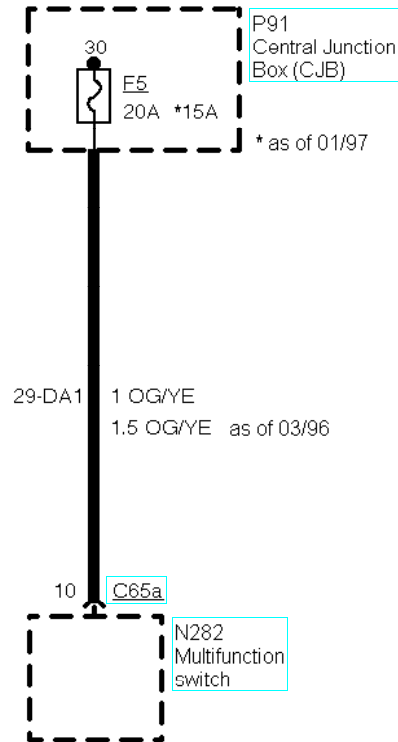

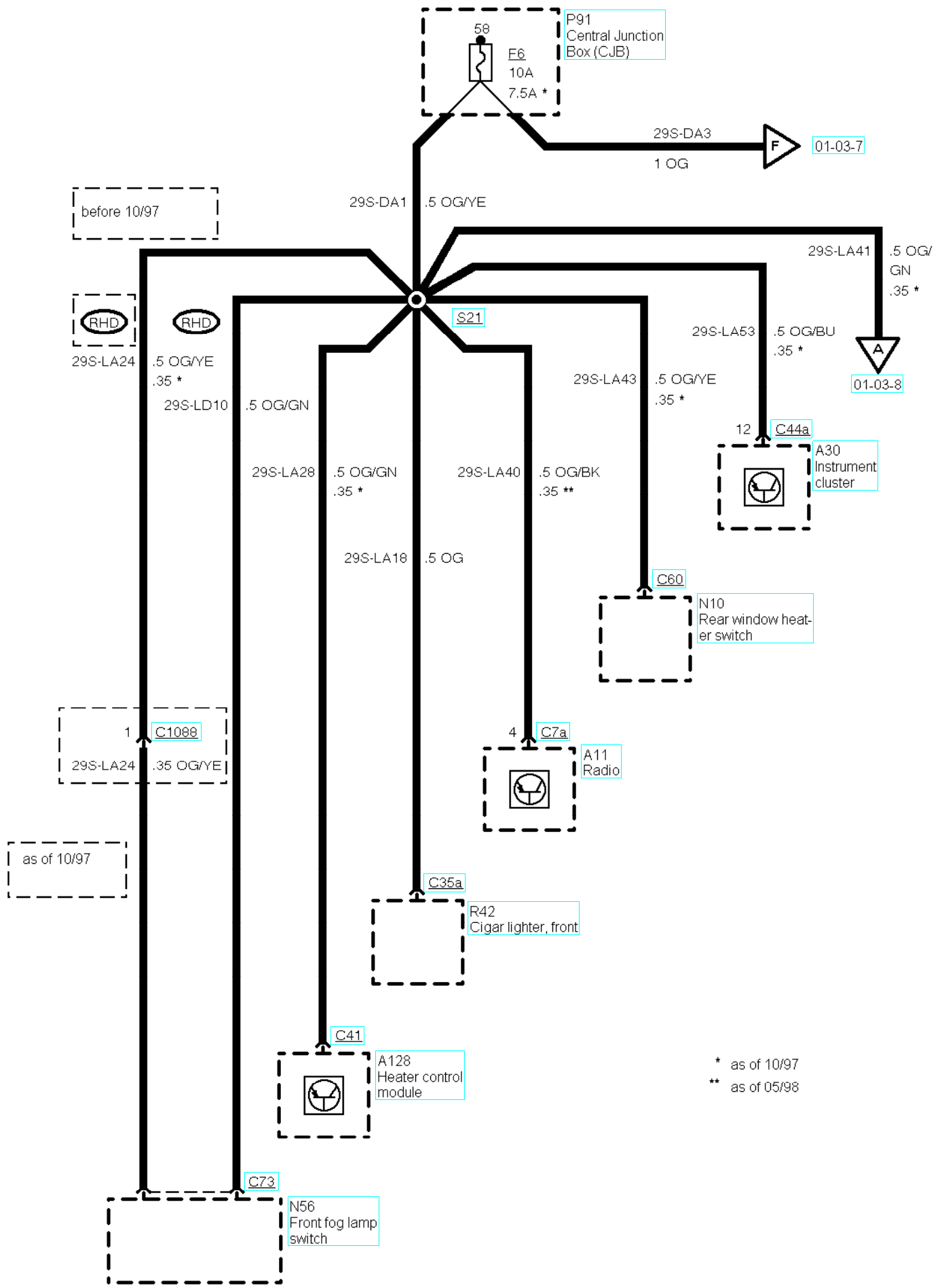

\* as of 10/97

\*\* Courier  
as of 05/98

PL H

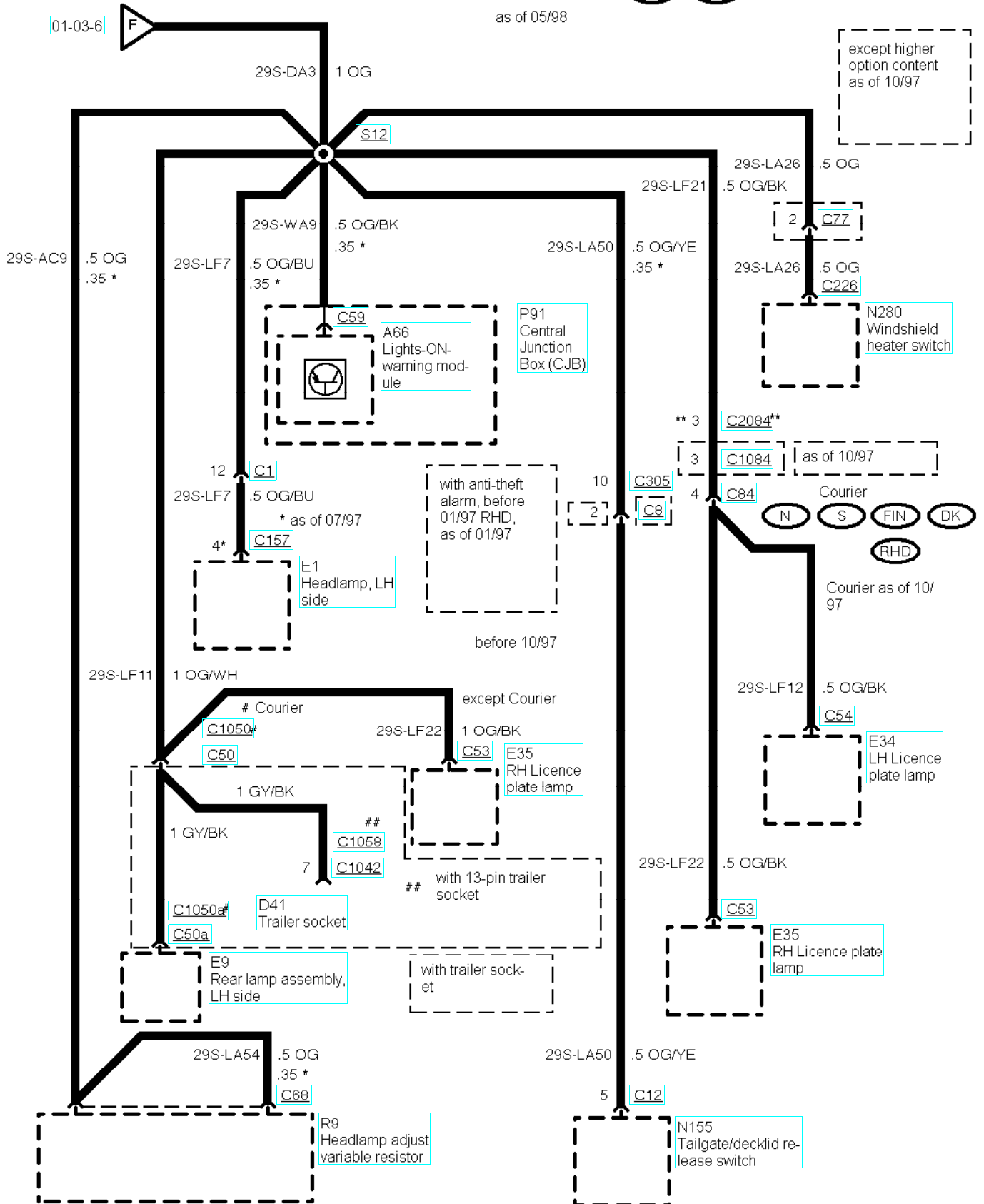

\* as of 10/97

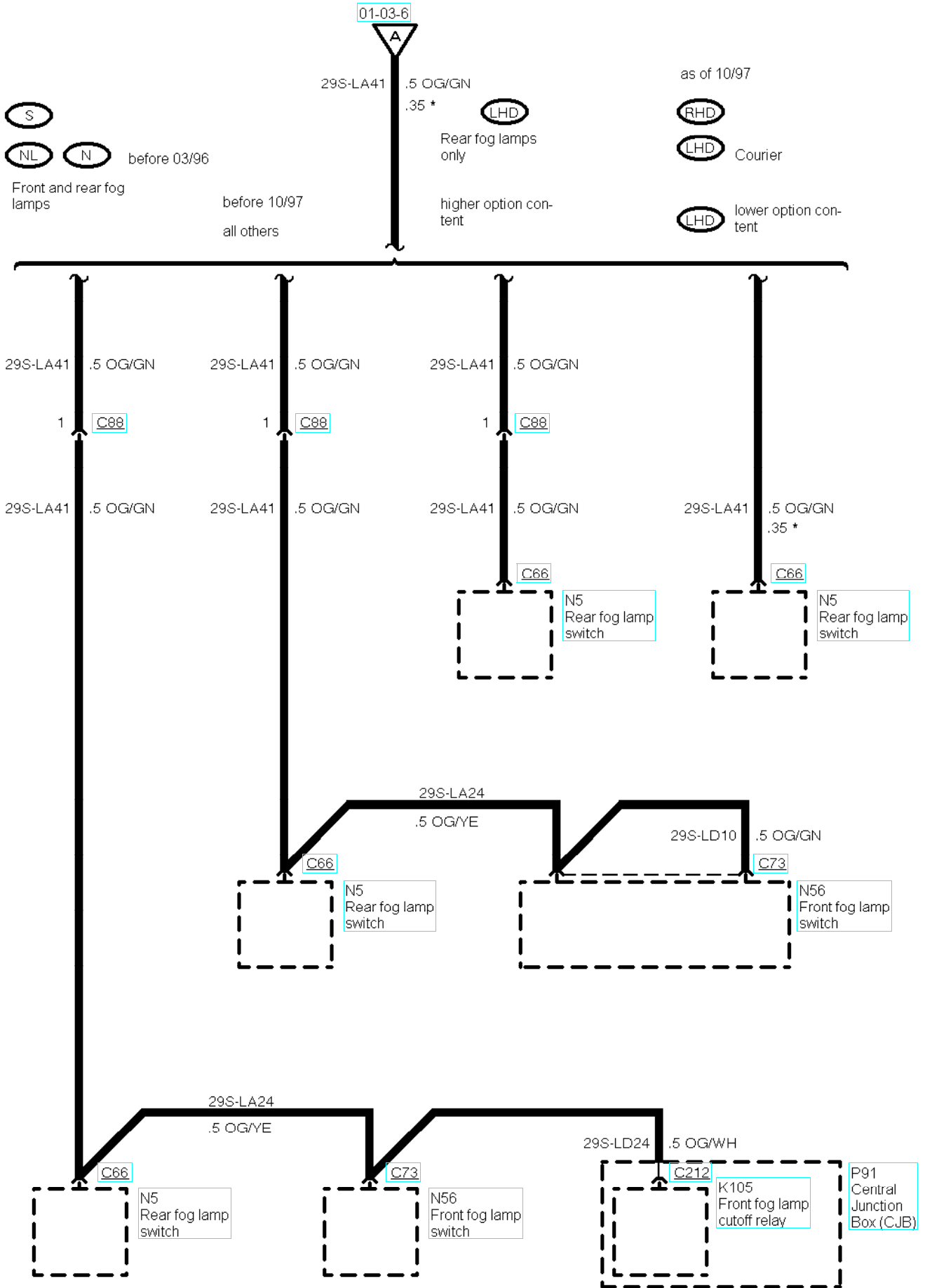

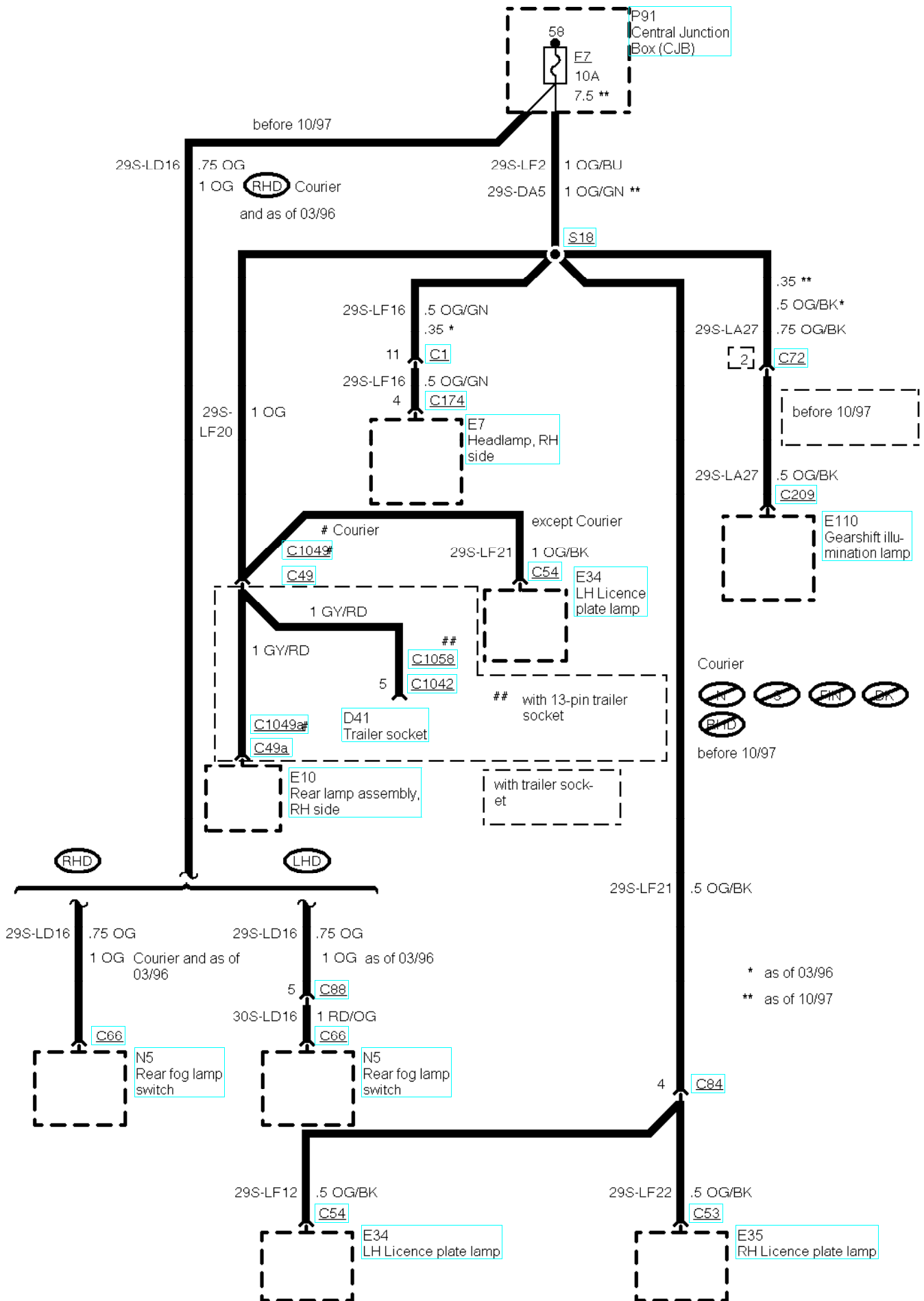



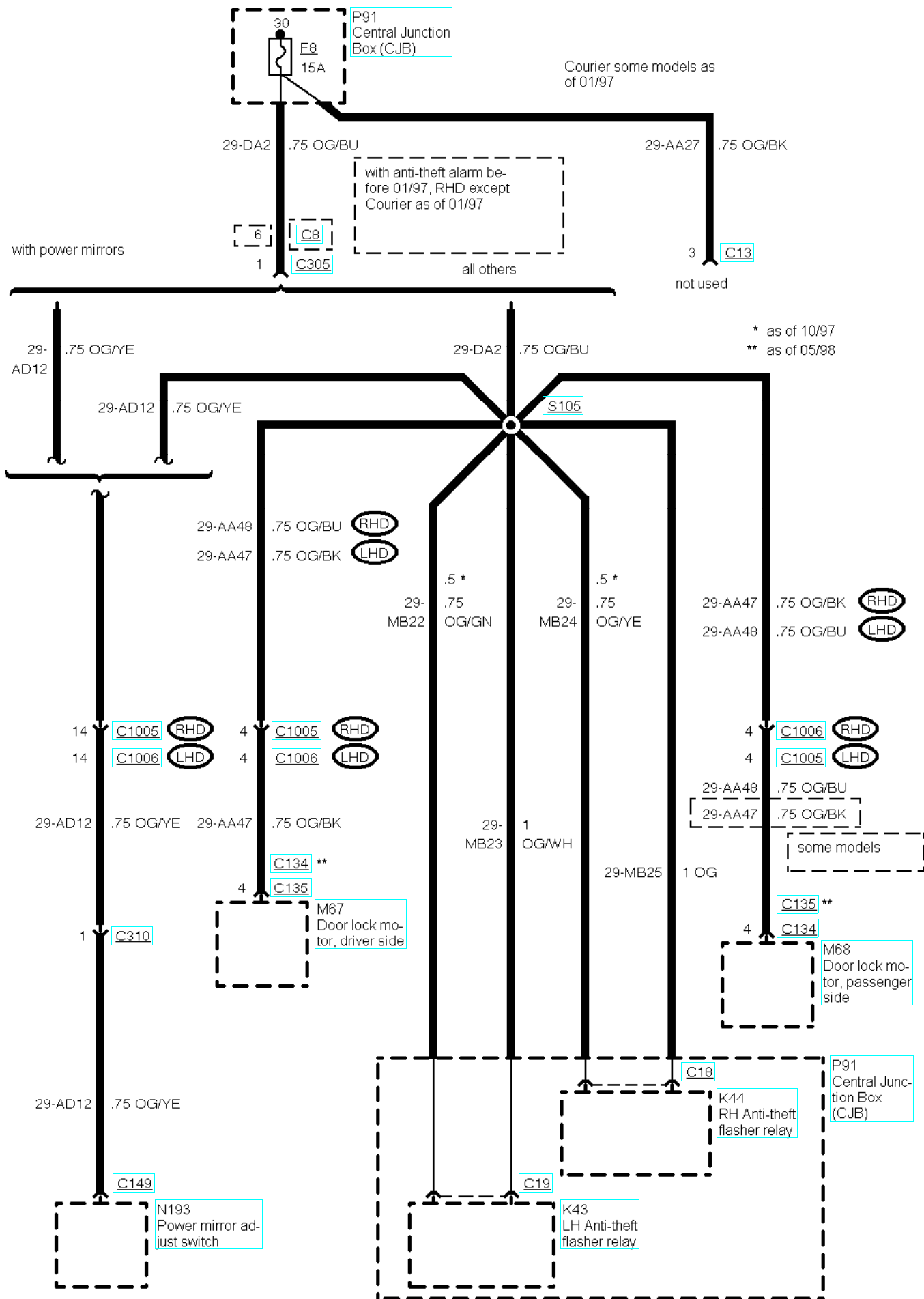

Fuse 9

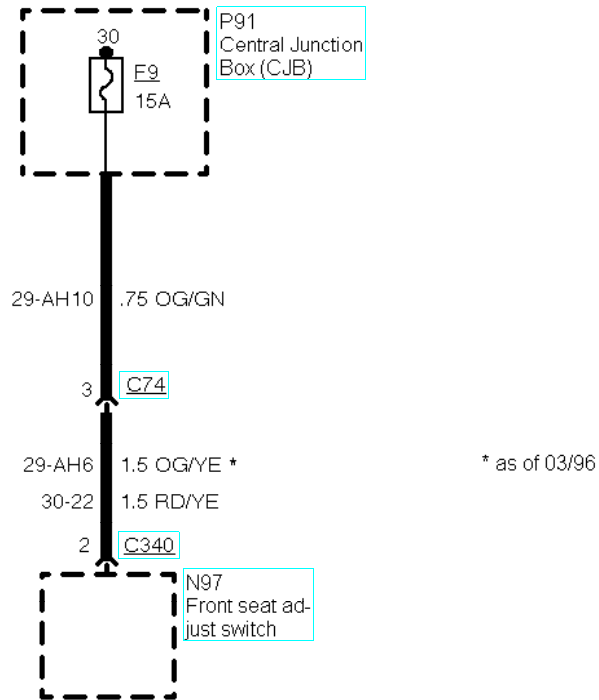

Fuse 10

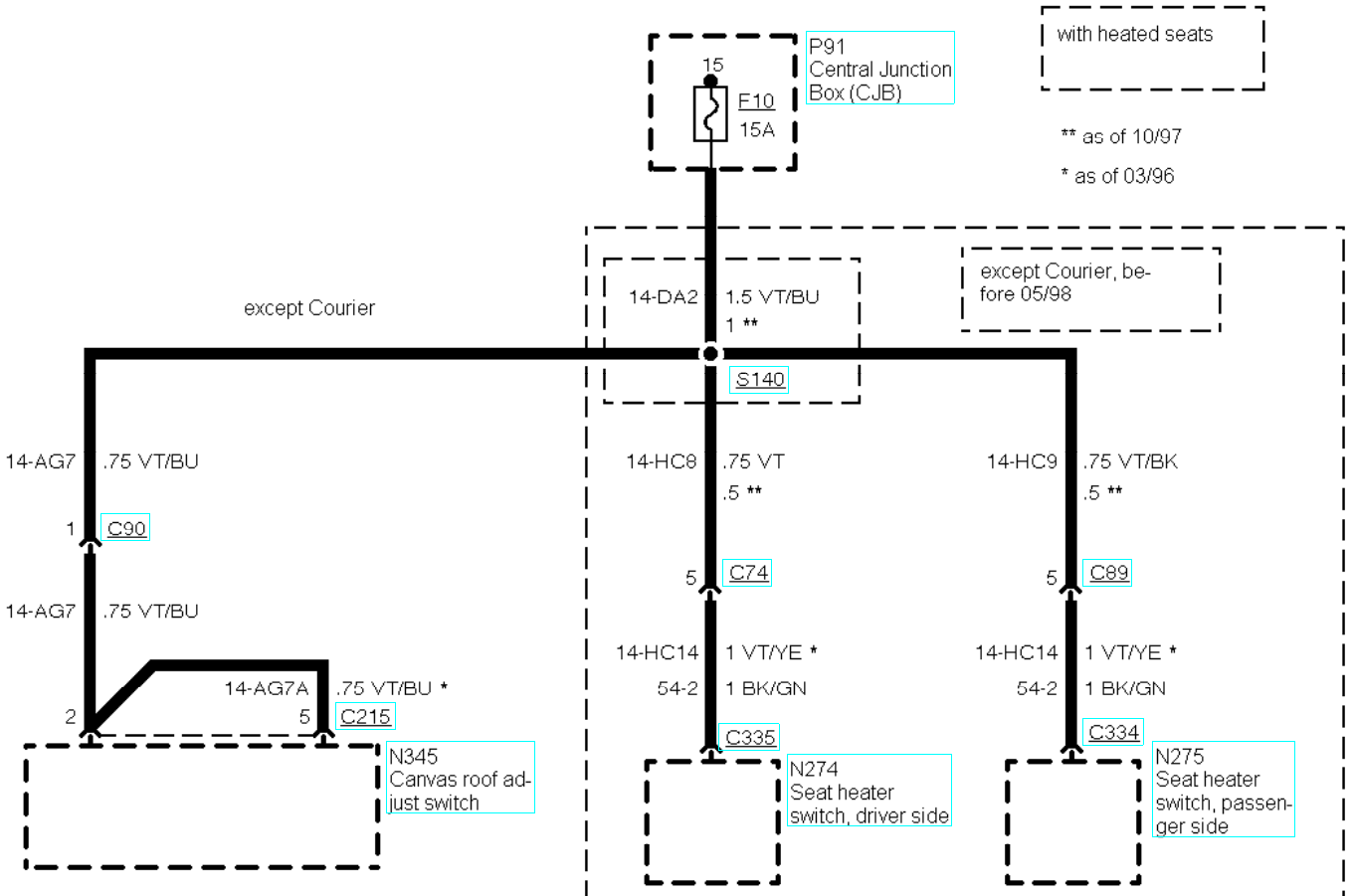

\* as of 01/97

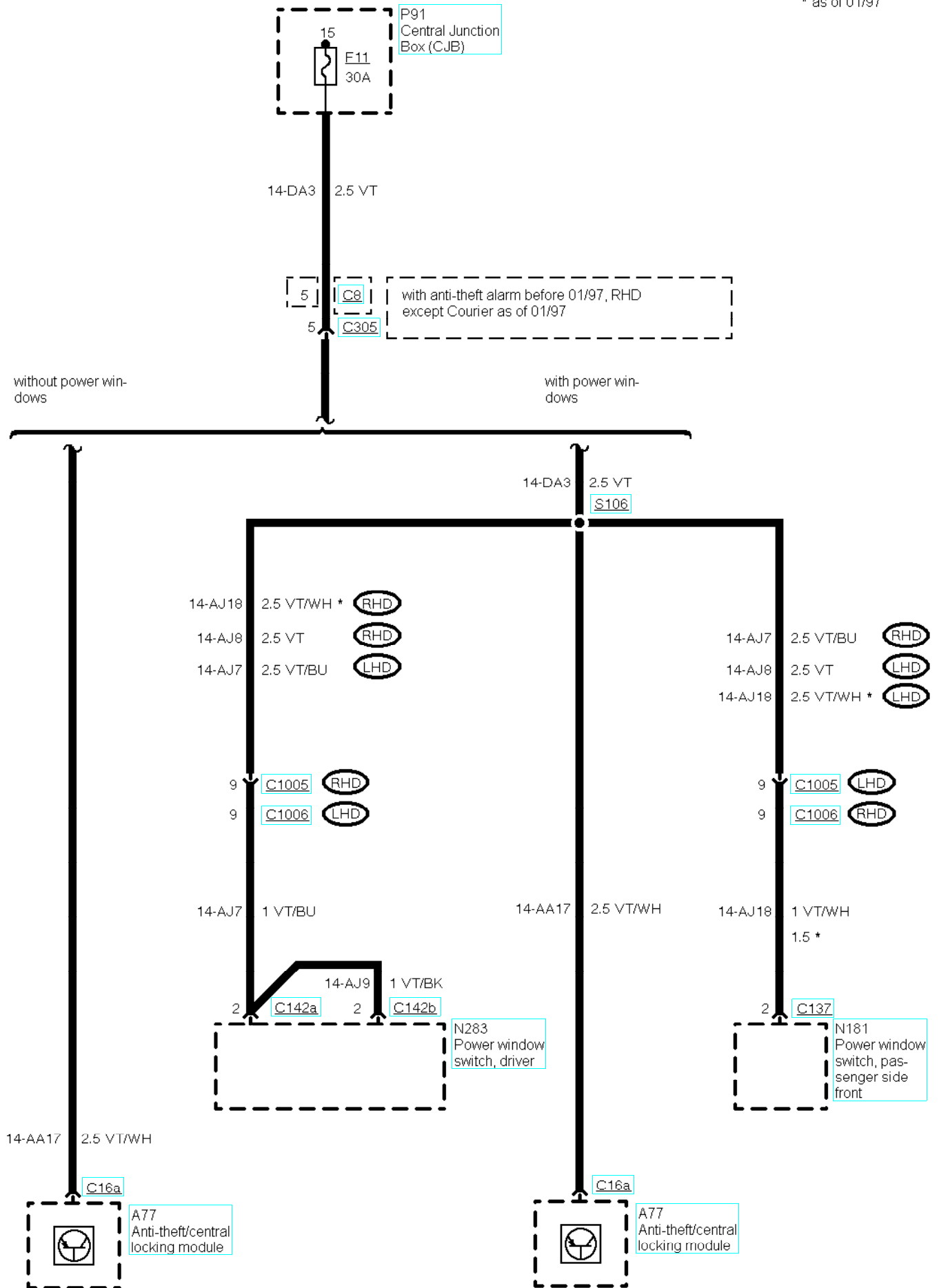

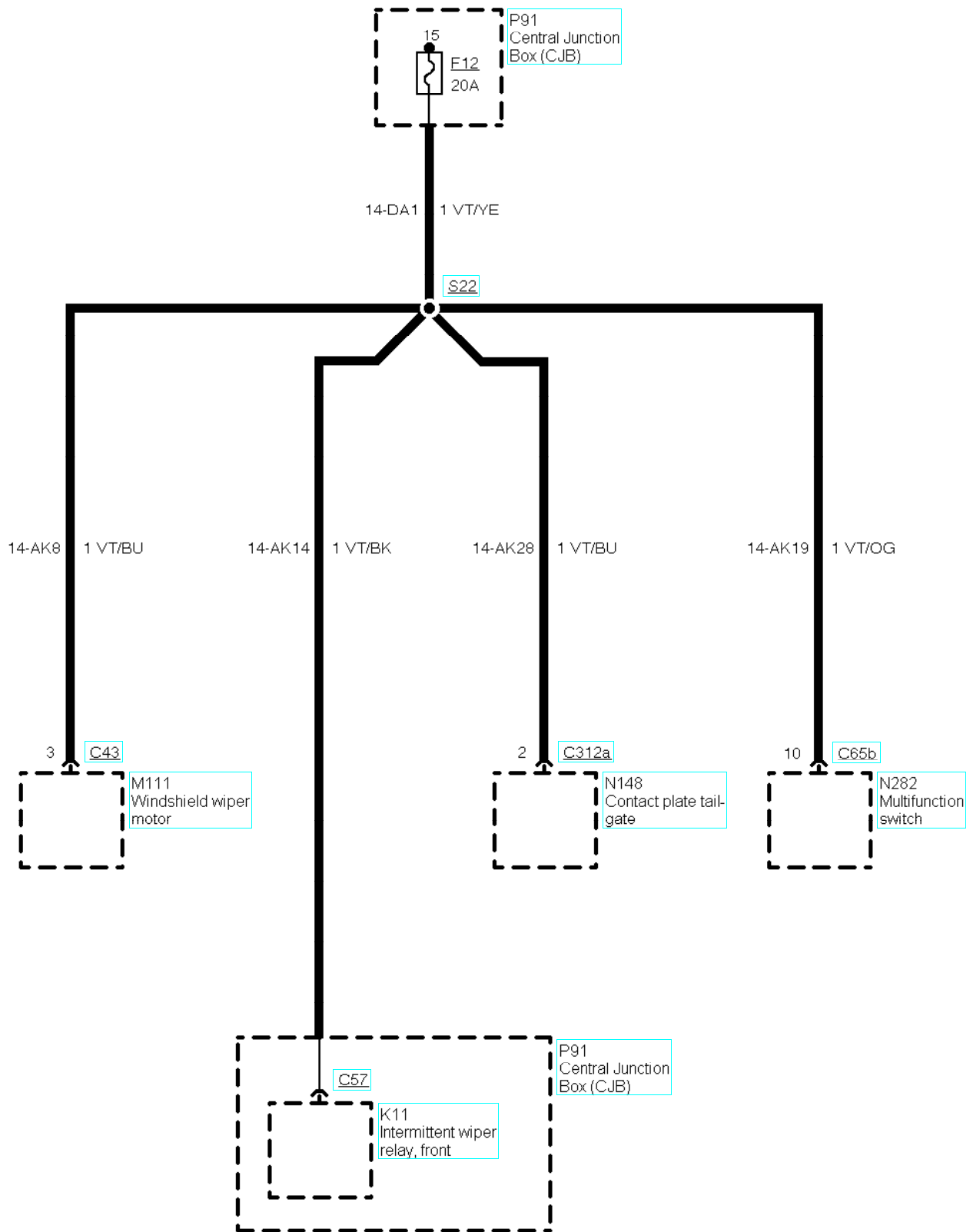

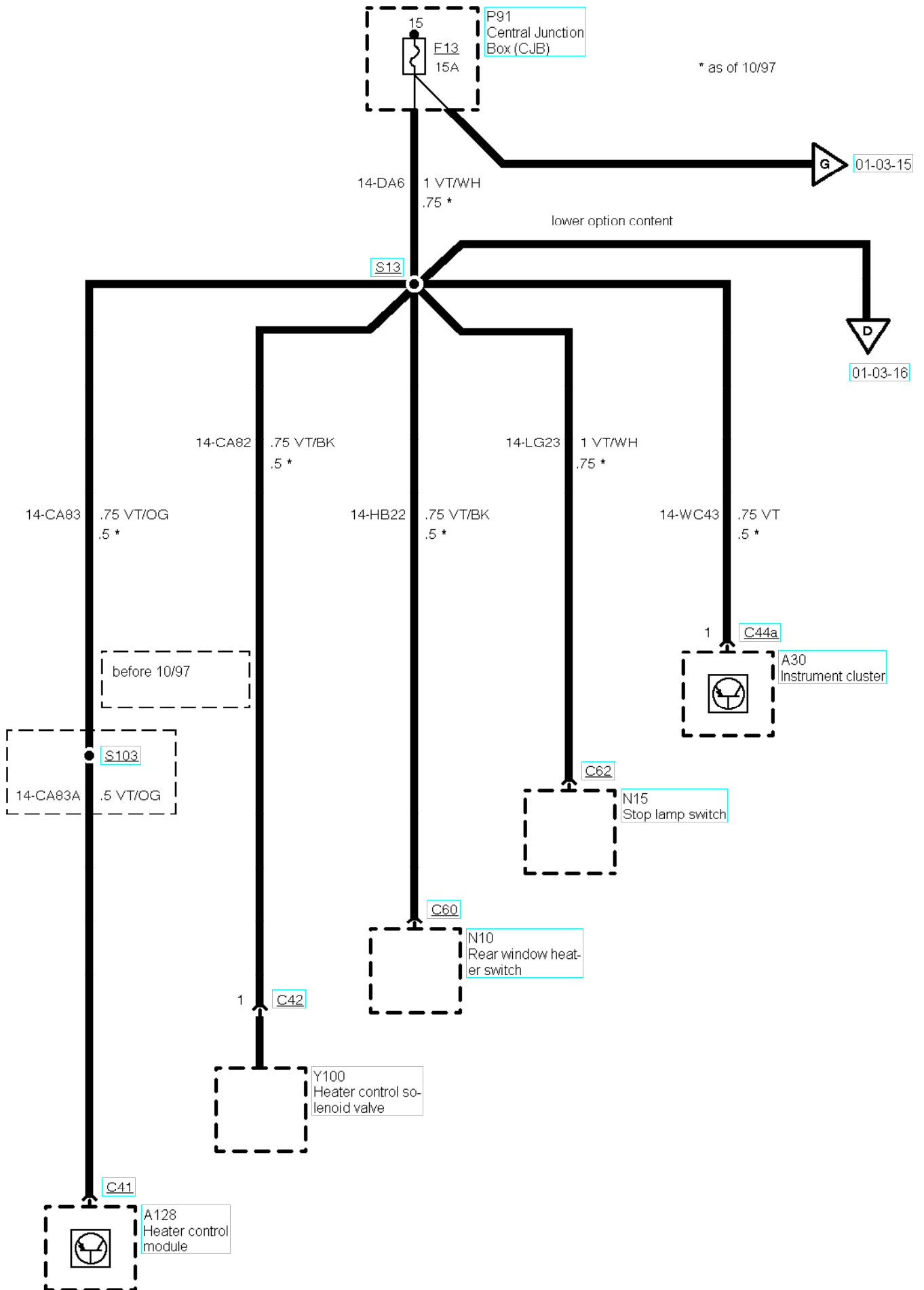

\* as of 10/97

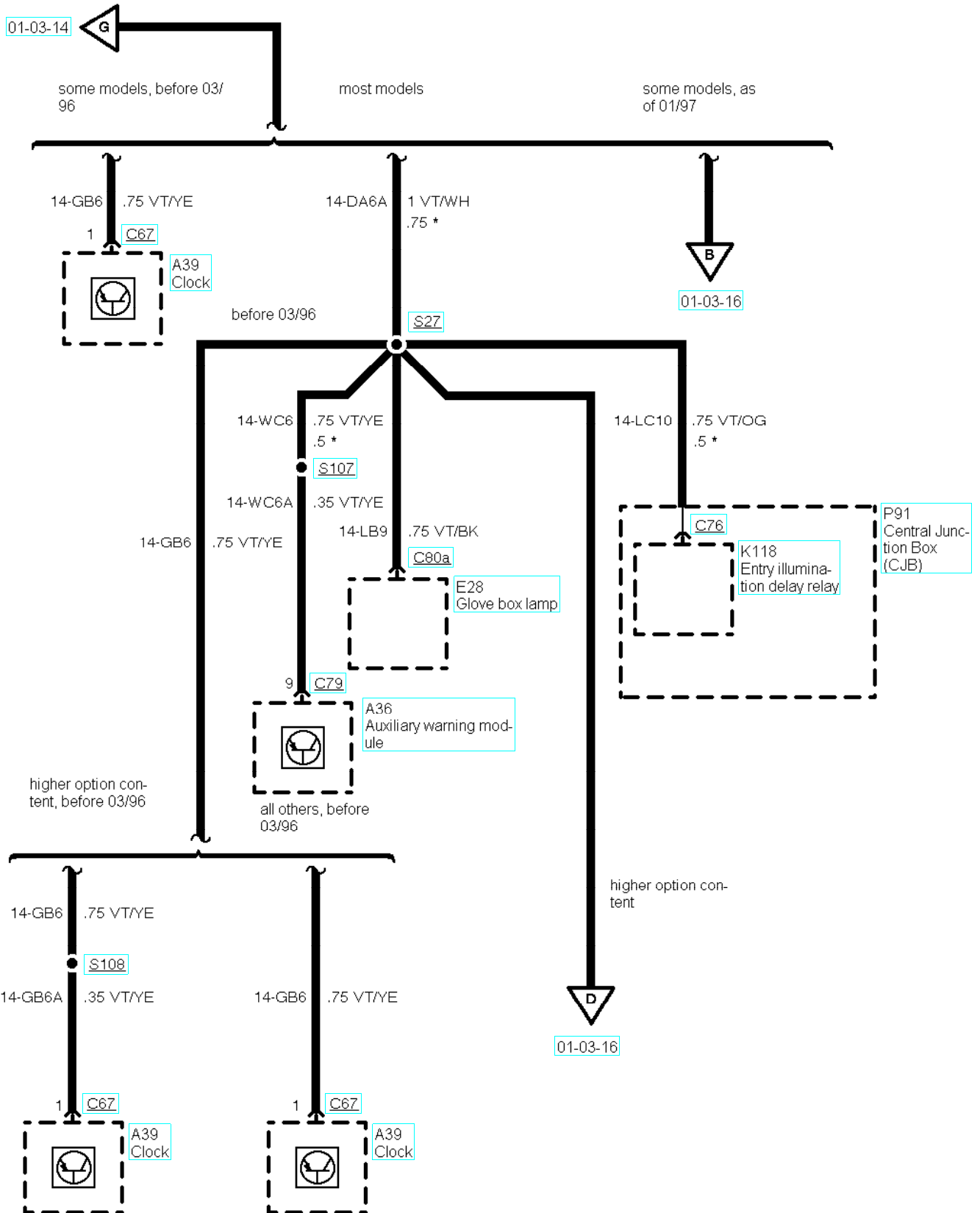

01-03-15  
01-03-14



\* as of 10/97

01-03-15



before 01/97

from 01/97 to 10/97

14-LG28 1 VT/WH  
.75 \*

15 C3 as of 10/97

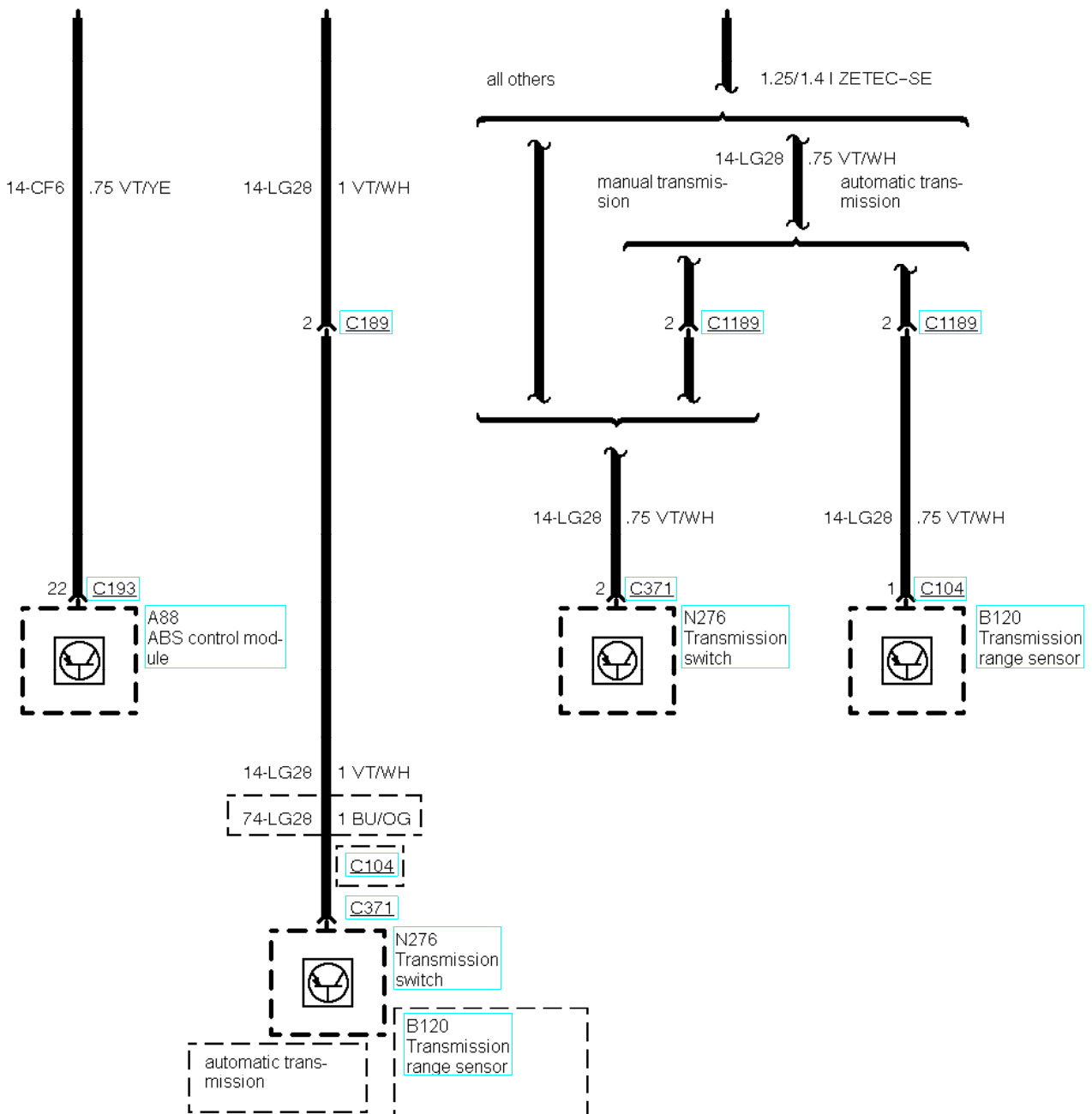

\* as of 01/97

\*\* as of 10/97

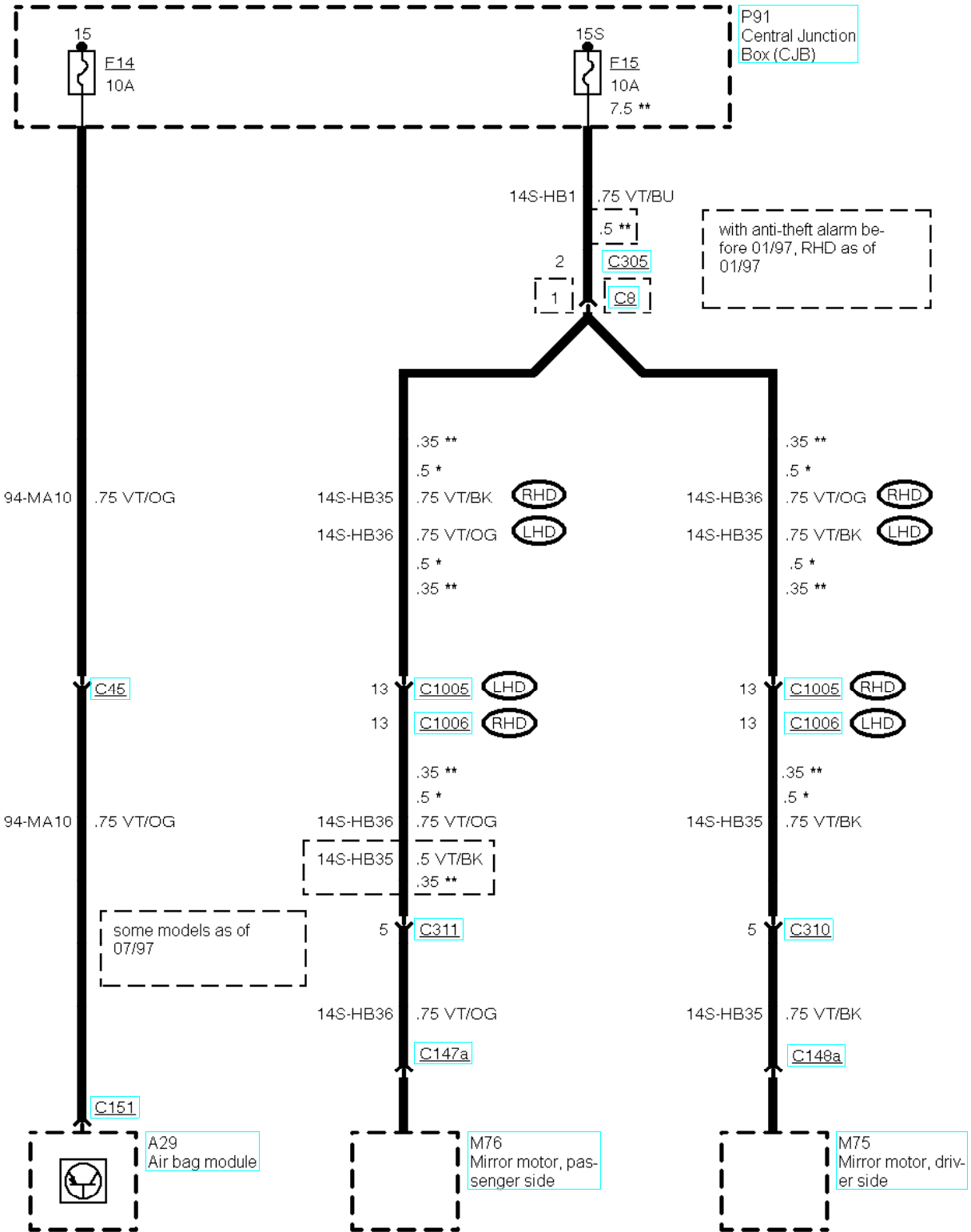



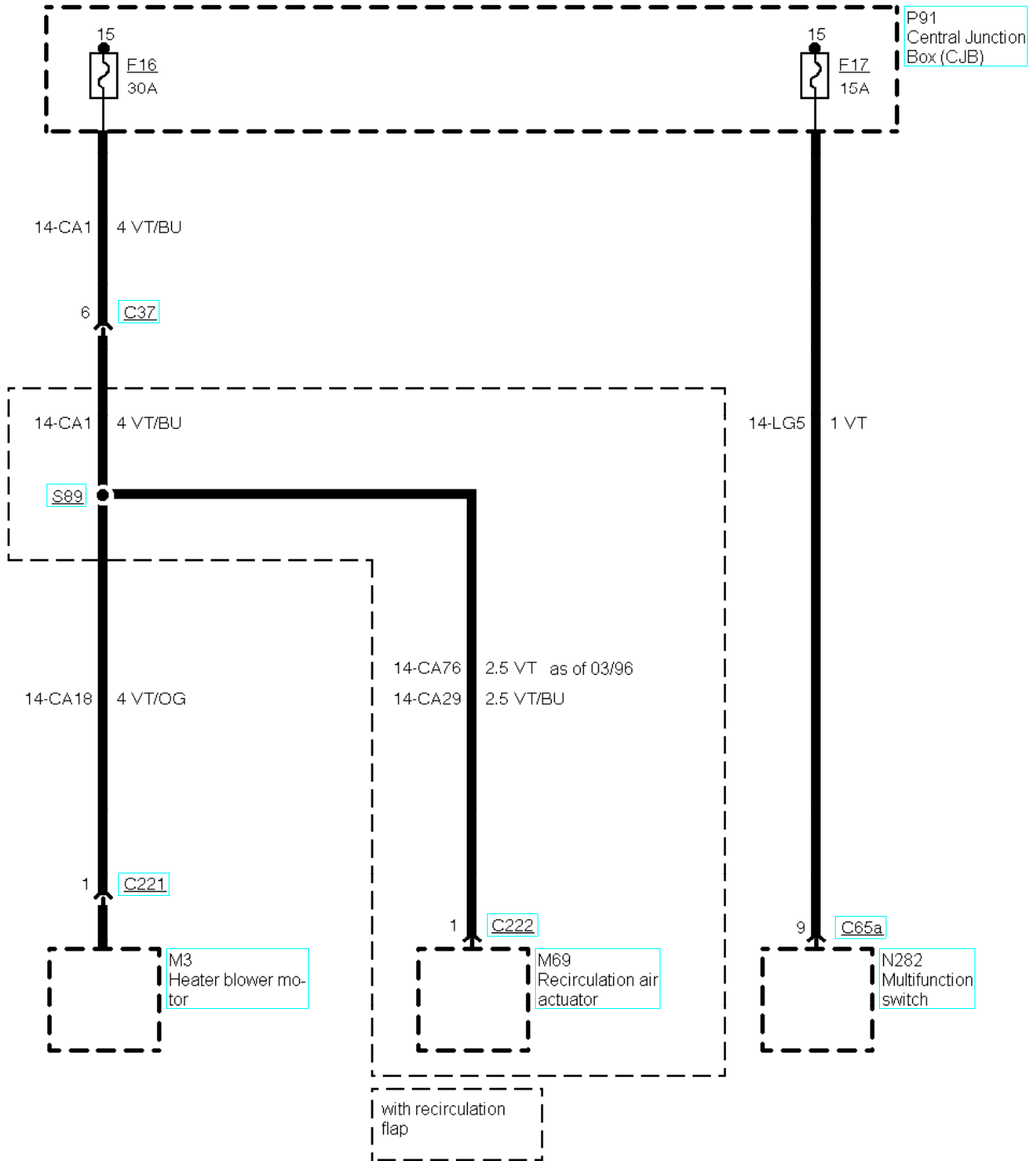

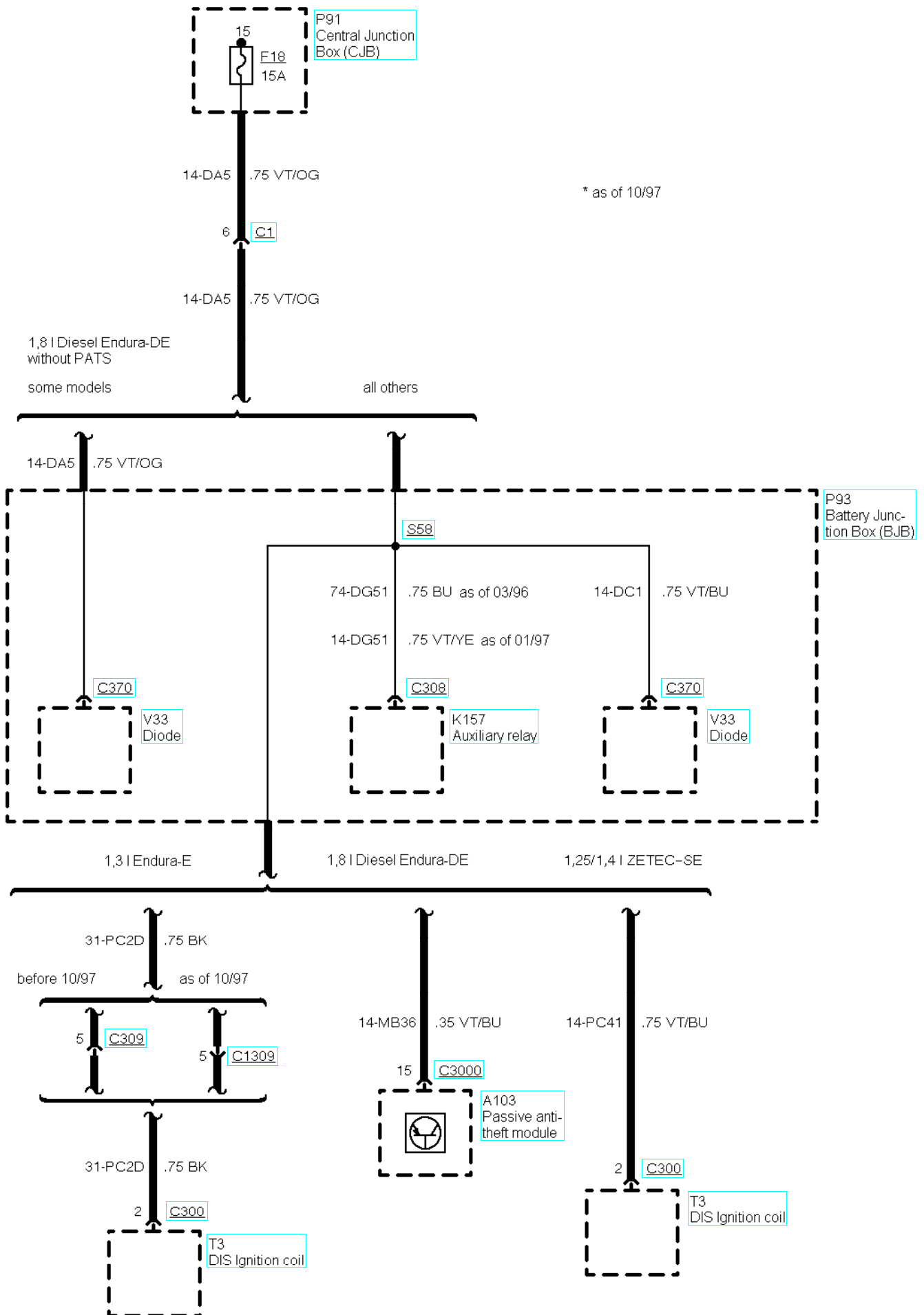

Before 03/96

RHD Reduced low series version

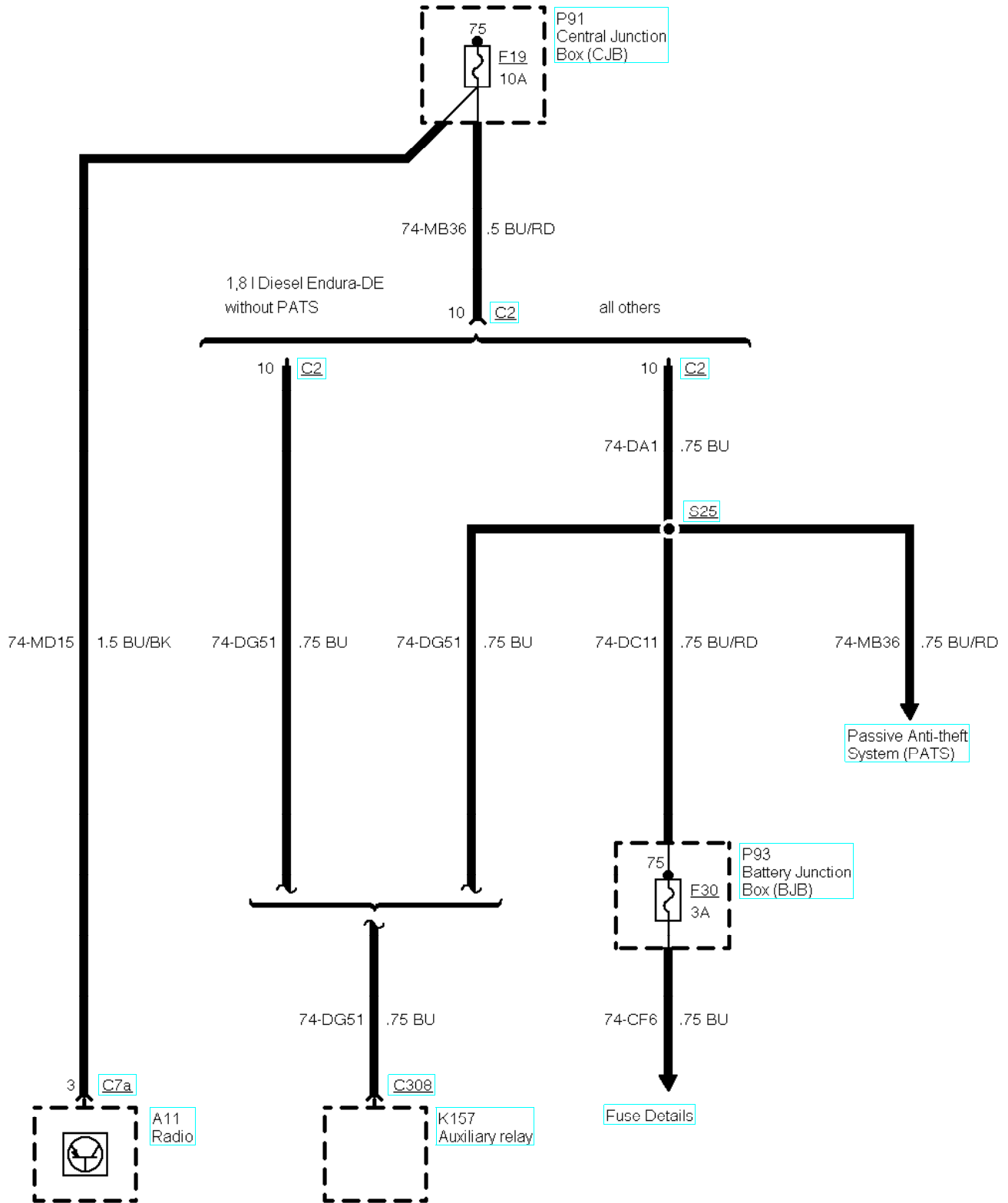

Before 03/96

Except RHD, Reduced low series version

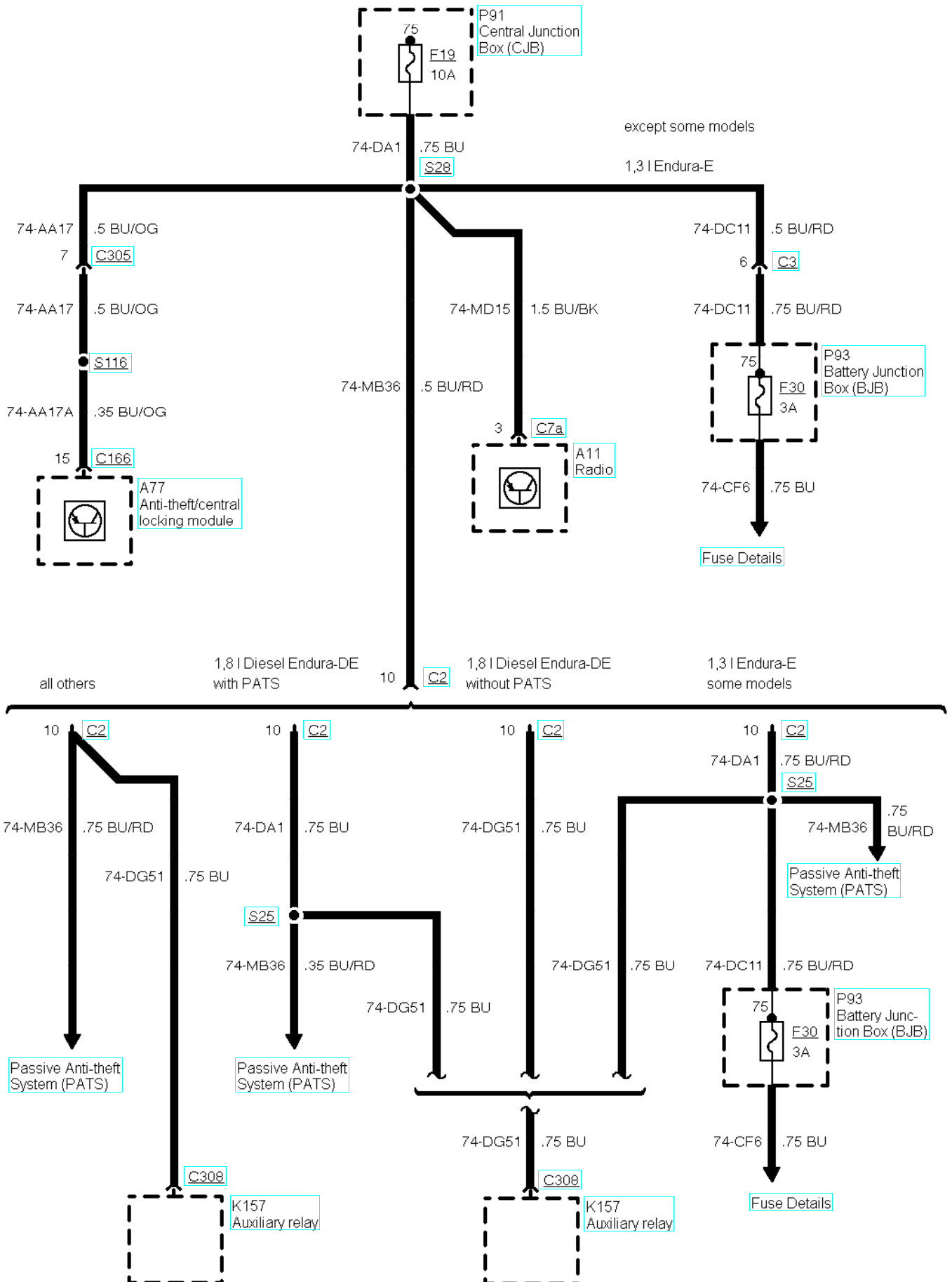

As of 03/96  
Without PATS

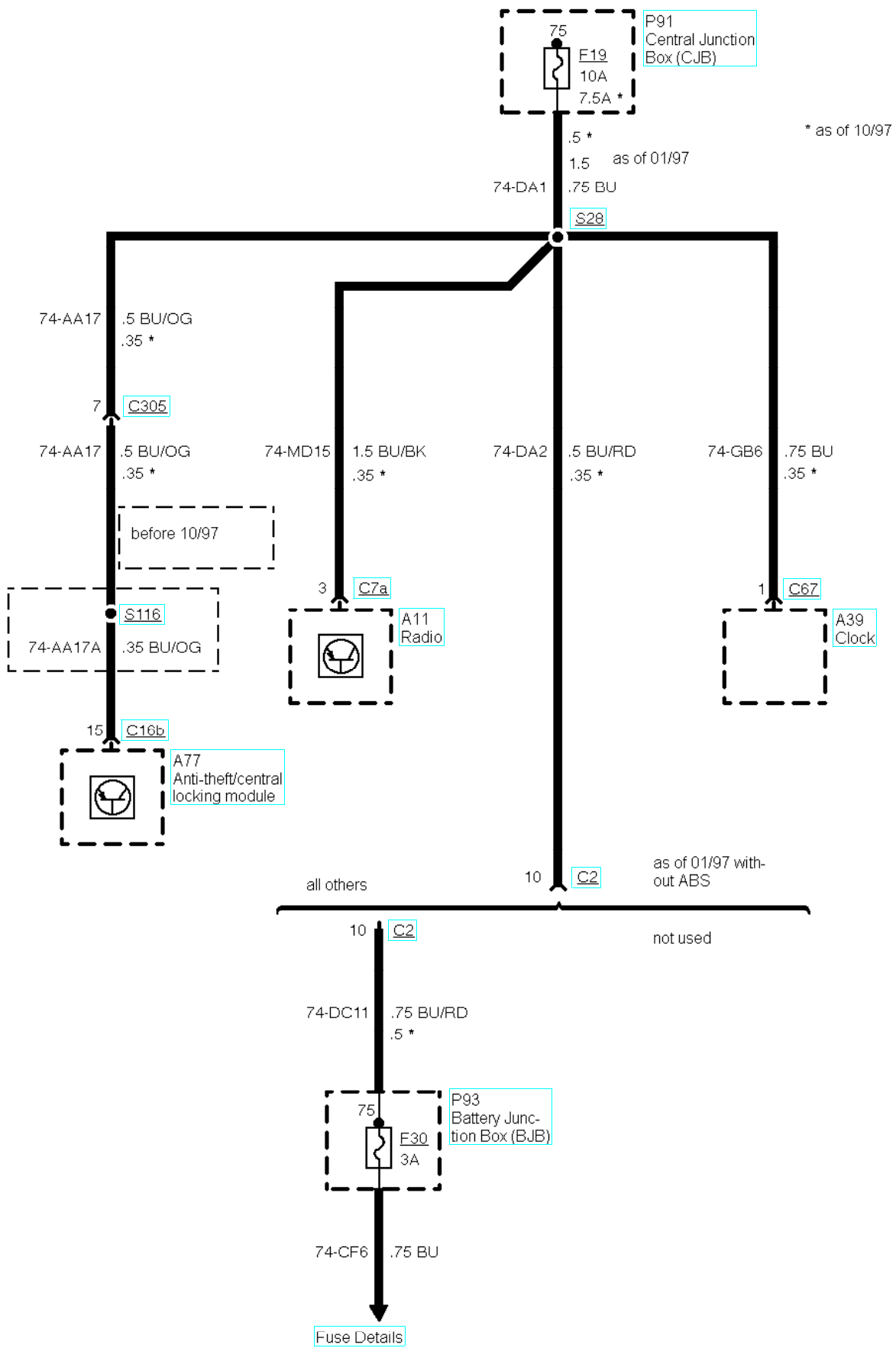

\* as of 10/97

before 10/97

as of 01/97 without ABS

not used

Fuse Details

As of 03/96

With PATS

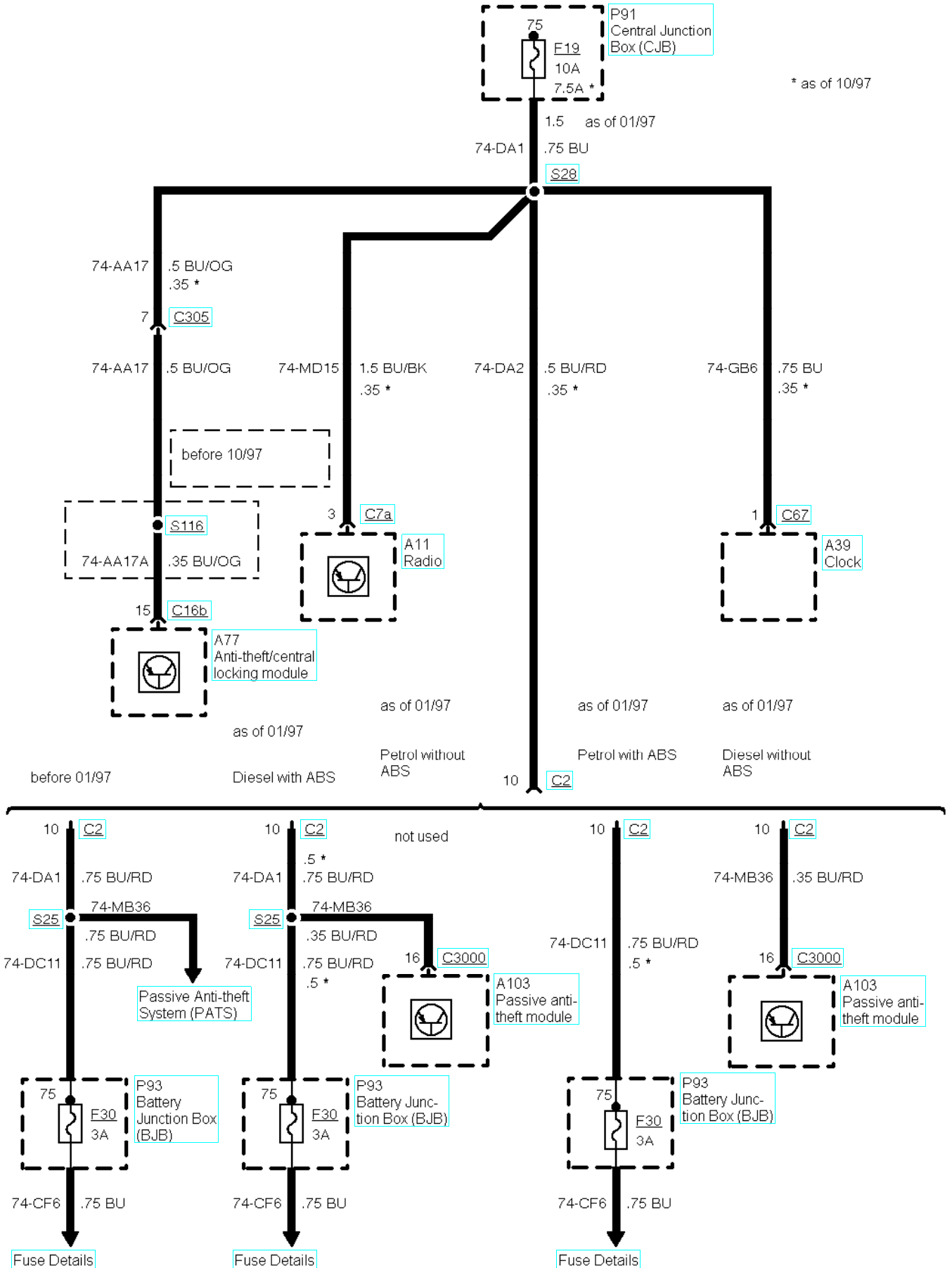

Fuse 20

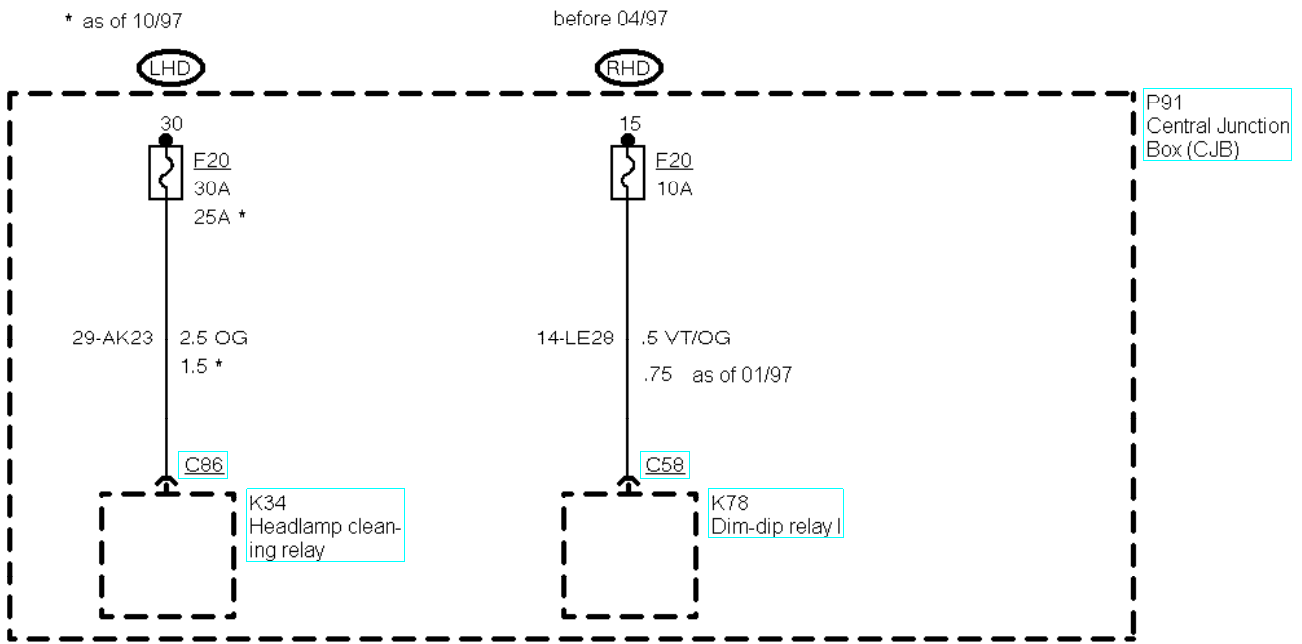

Fuses 21 and 22

Scandinavia

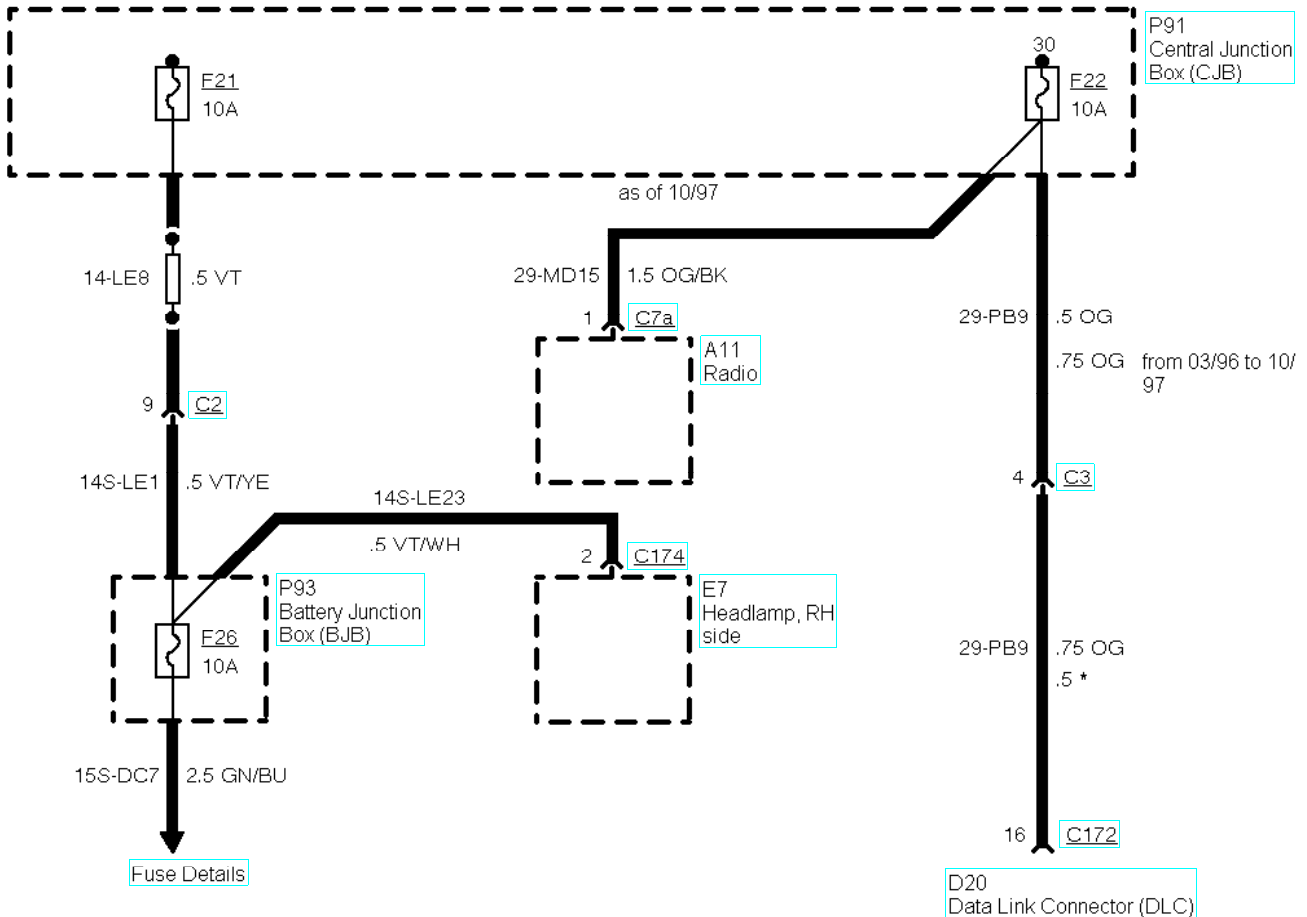

Fuse 23

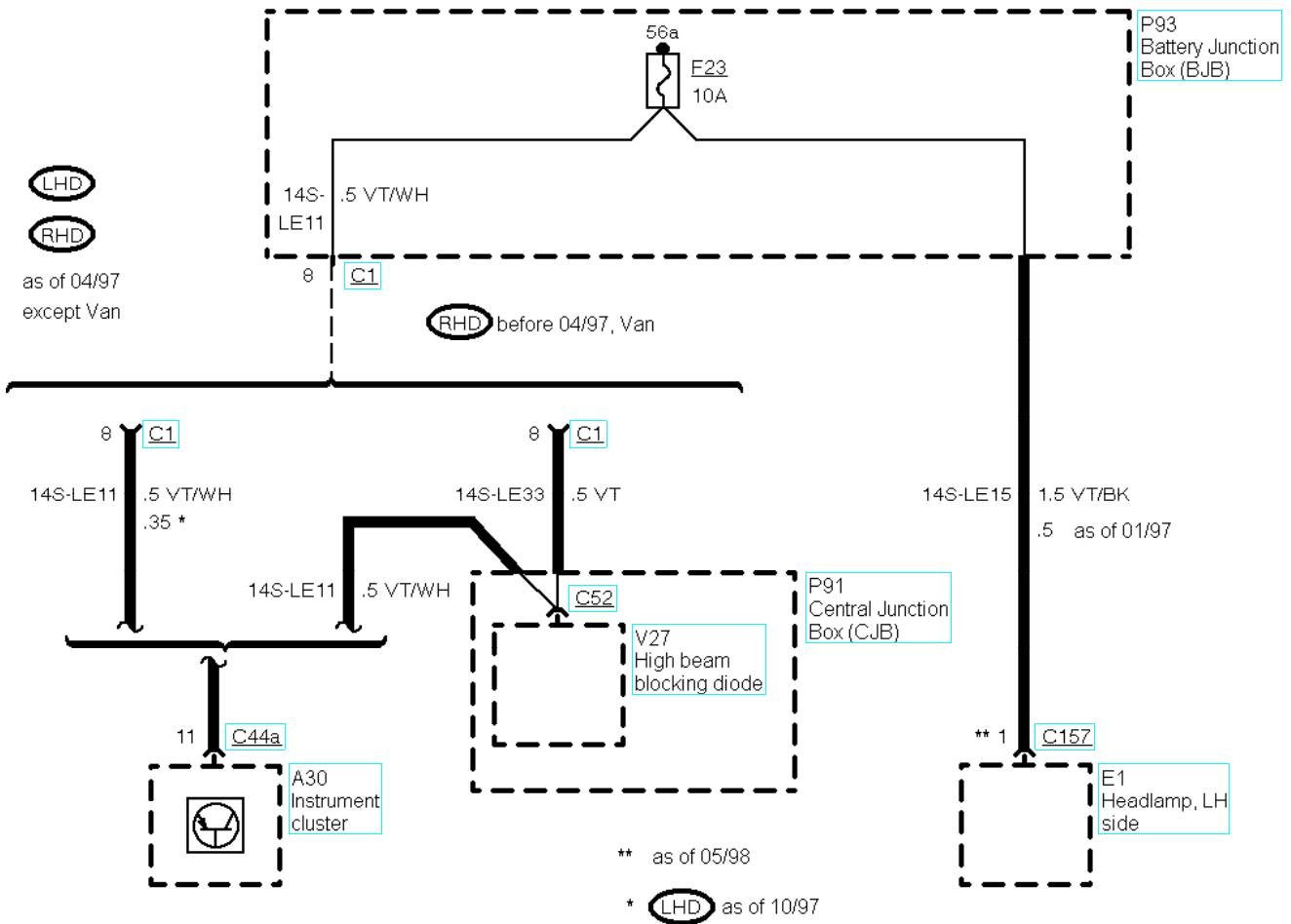

Fuses 24 and 25

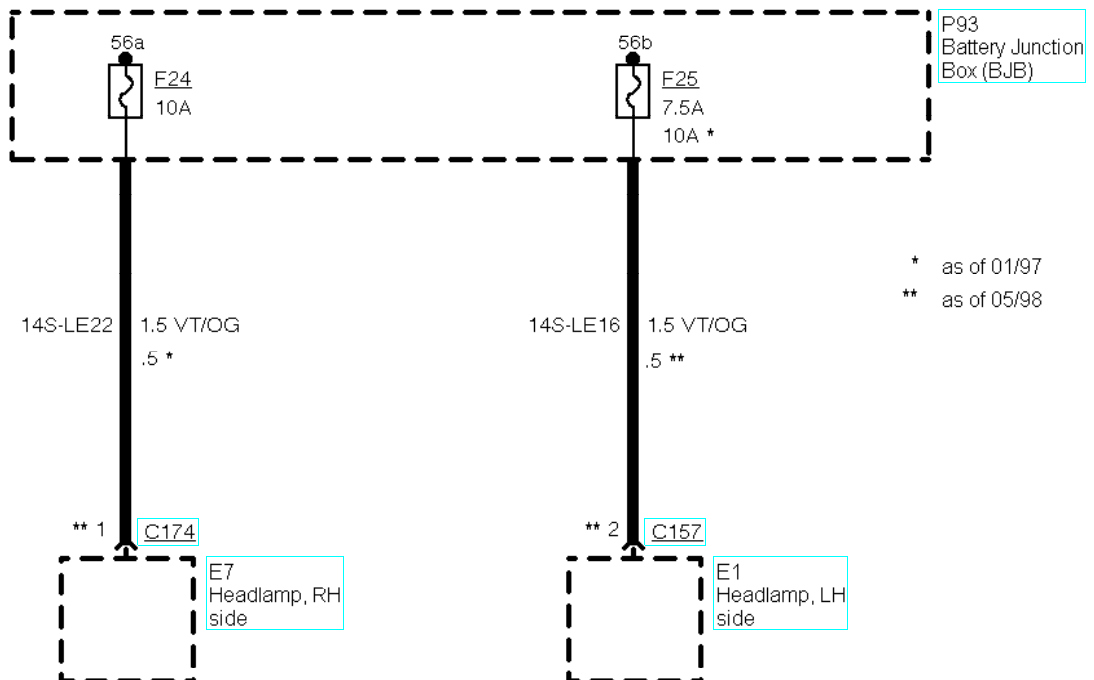



Fuse 26

as of 10/97  
Low beam

as of 10/97  
with daytime running lamps

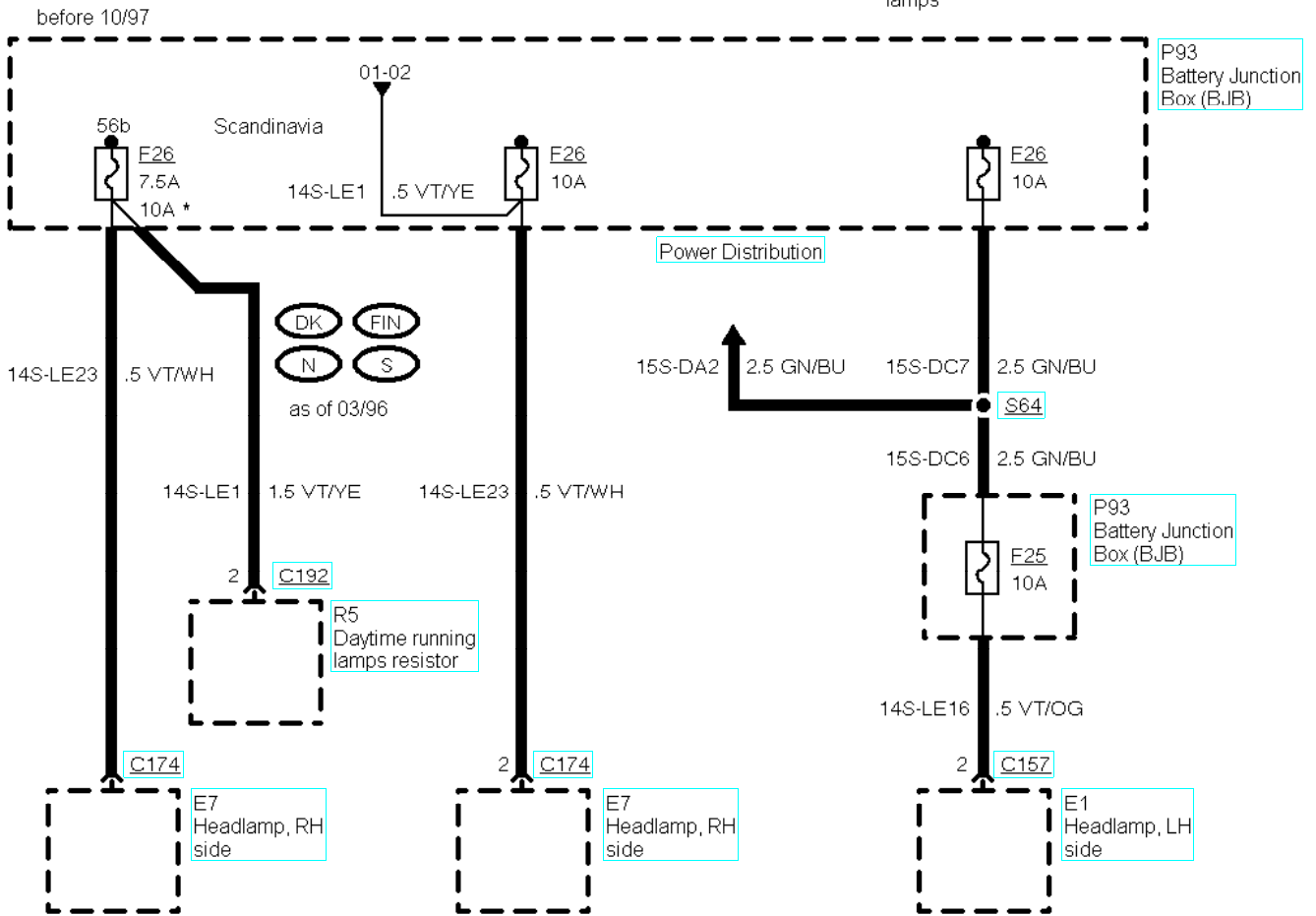

Fuse 27

before 05/98  
1,25|1,4| ZETEC-SE  
1,3| Endura-E

as of 05/98  
1,25| ZETEC-SE automa-  
tic transmission 1,4|  
ZETEC-SE

as of 05/98  
1,25| ZETEC-SE manual  
transmission 1,3| Endura-E

1,8| Diesel Endura-DE

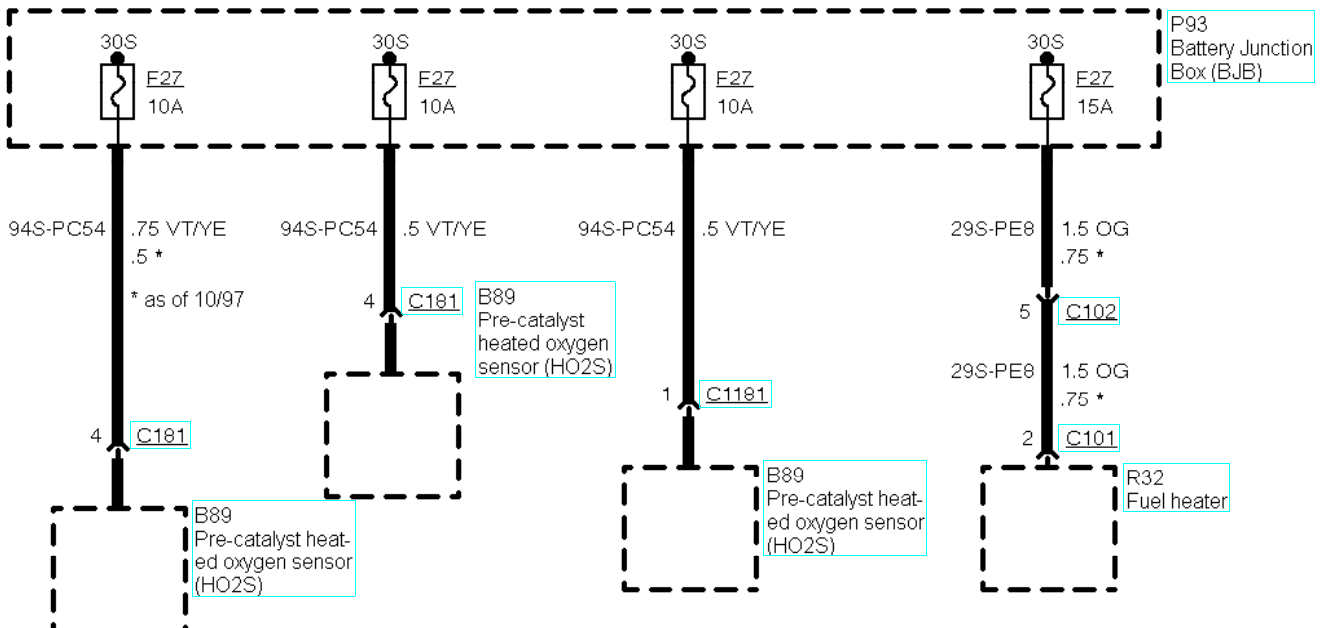

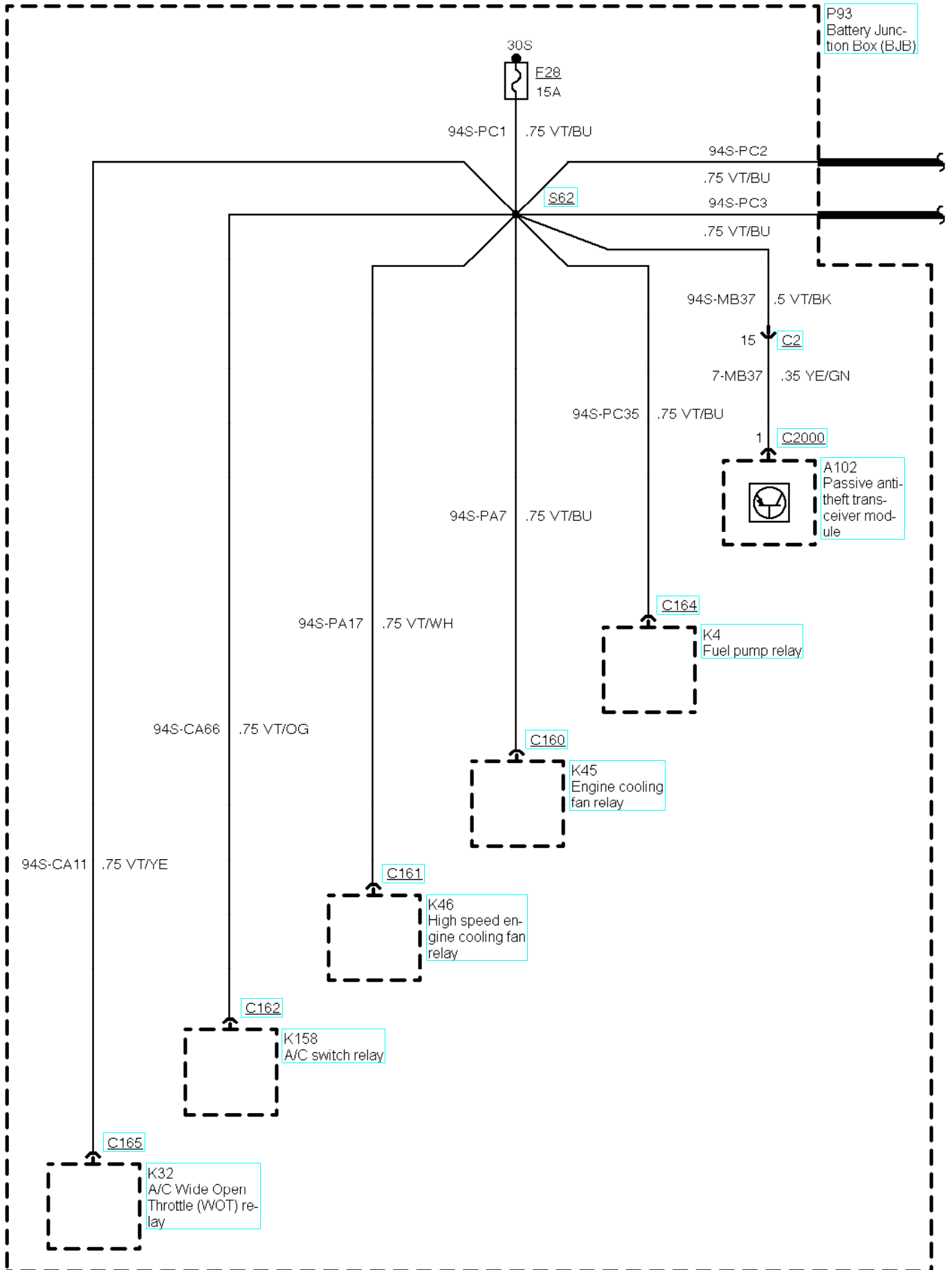

except diesel

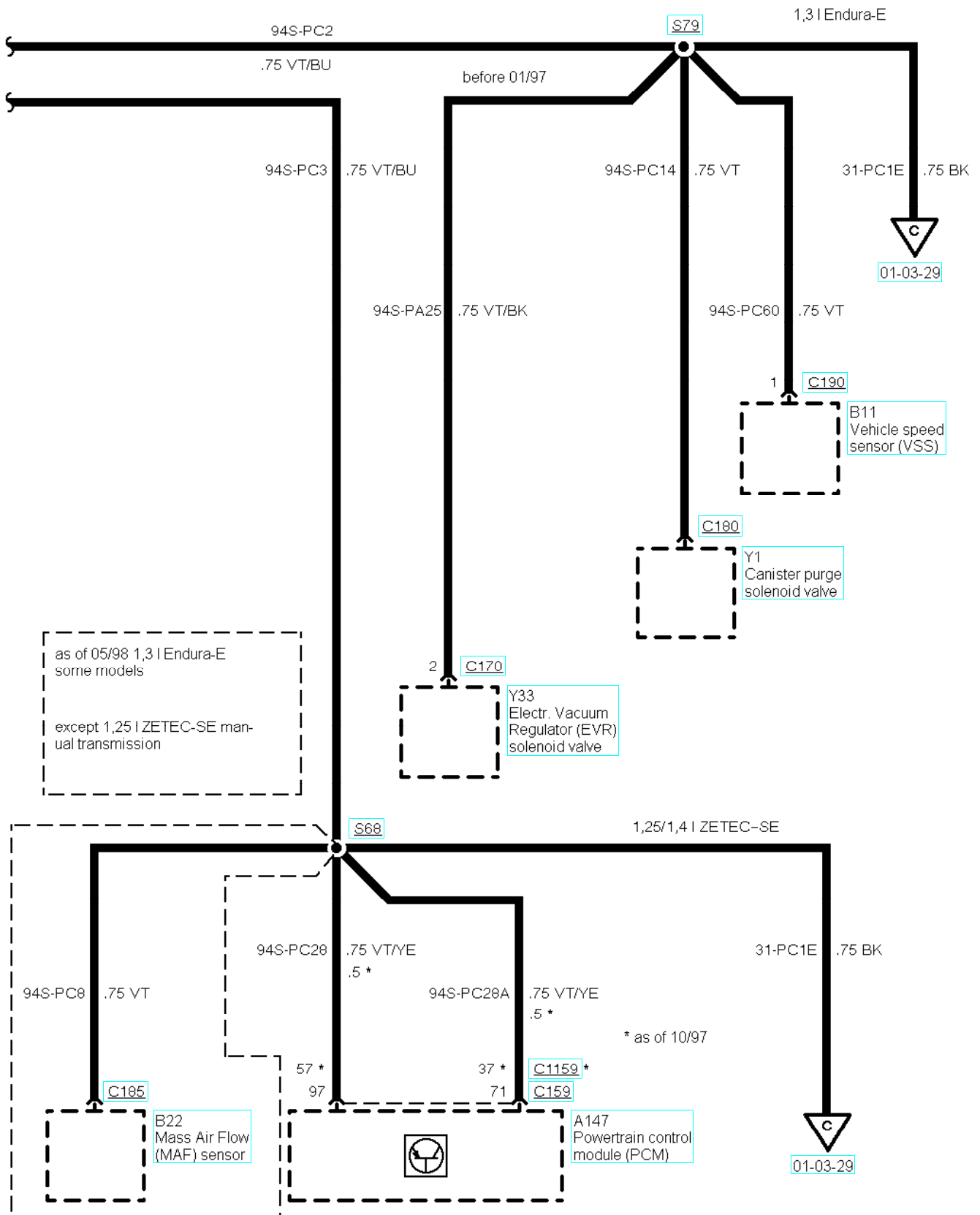

except diesel

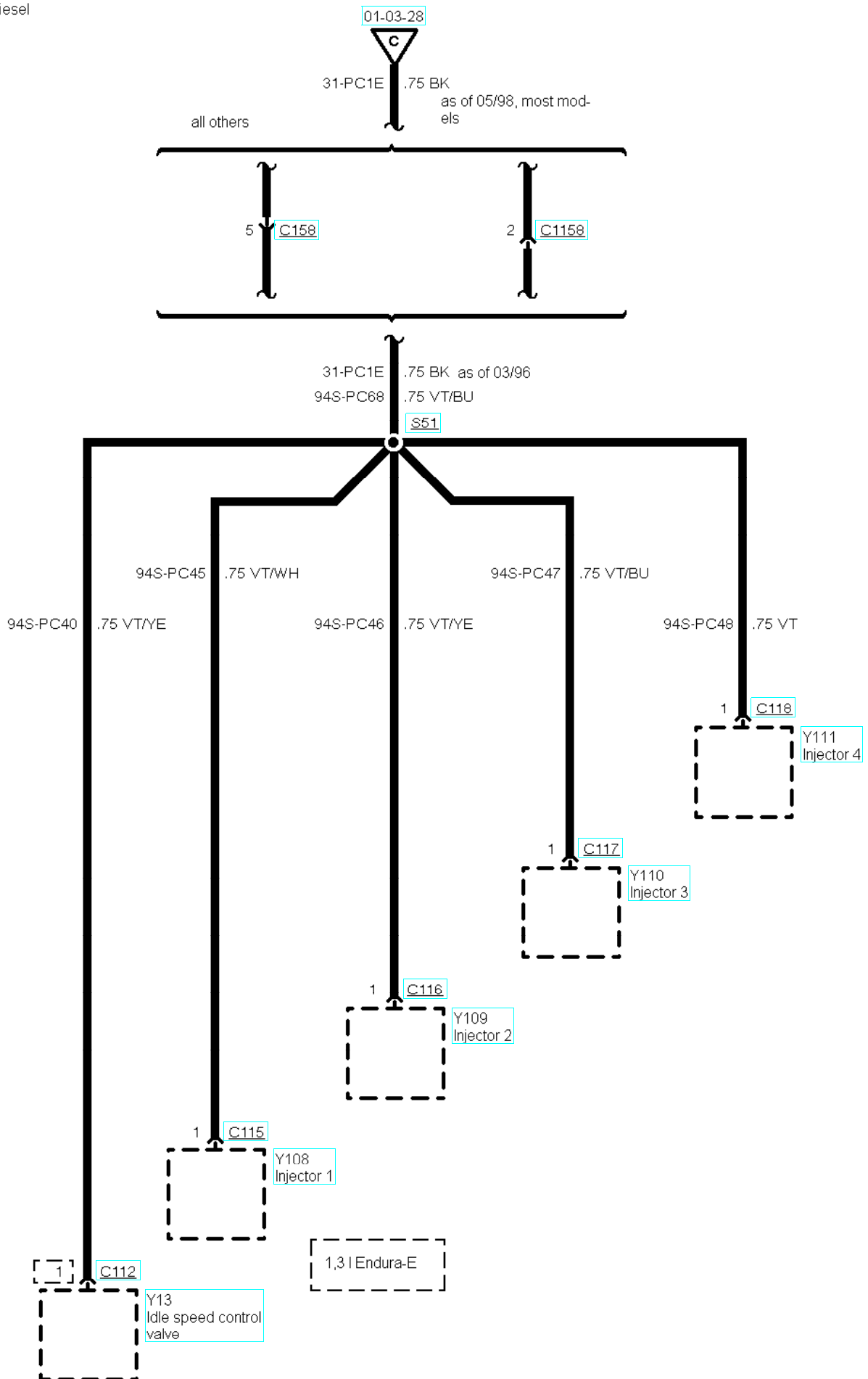

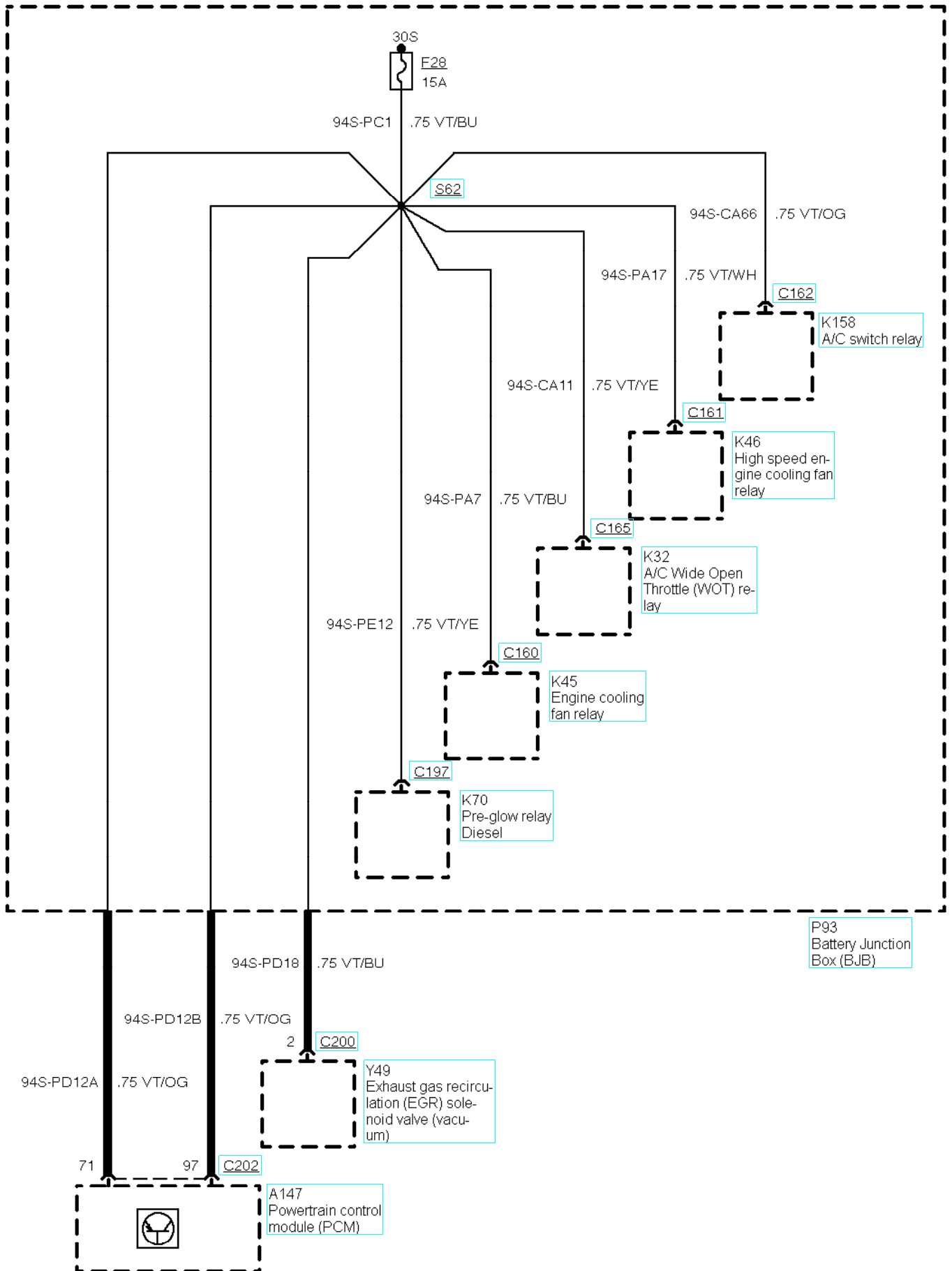

\* as of 01/97

\*\* as of 10/97

\*\*\* as of 05/98

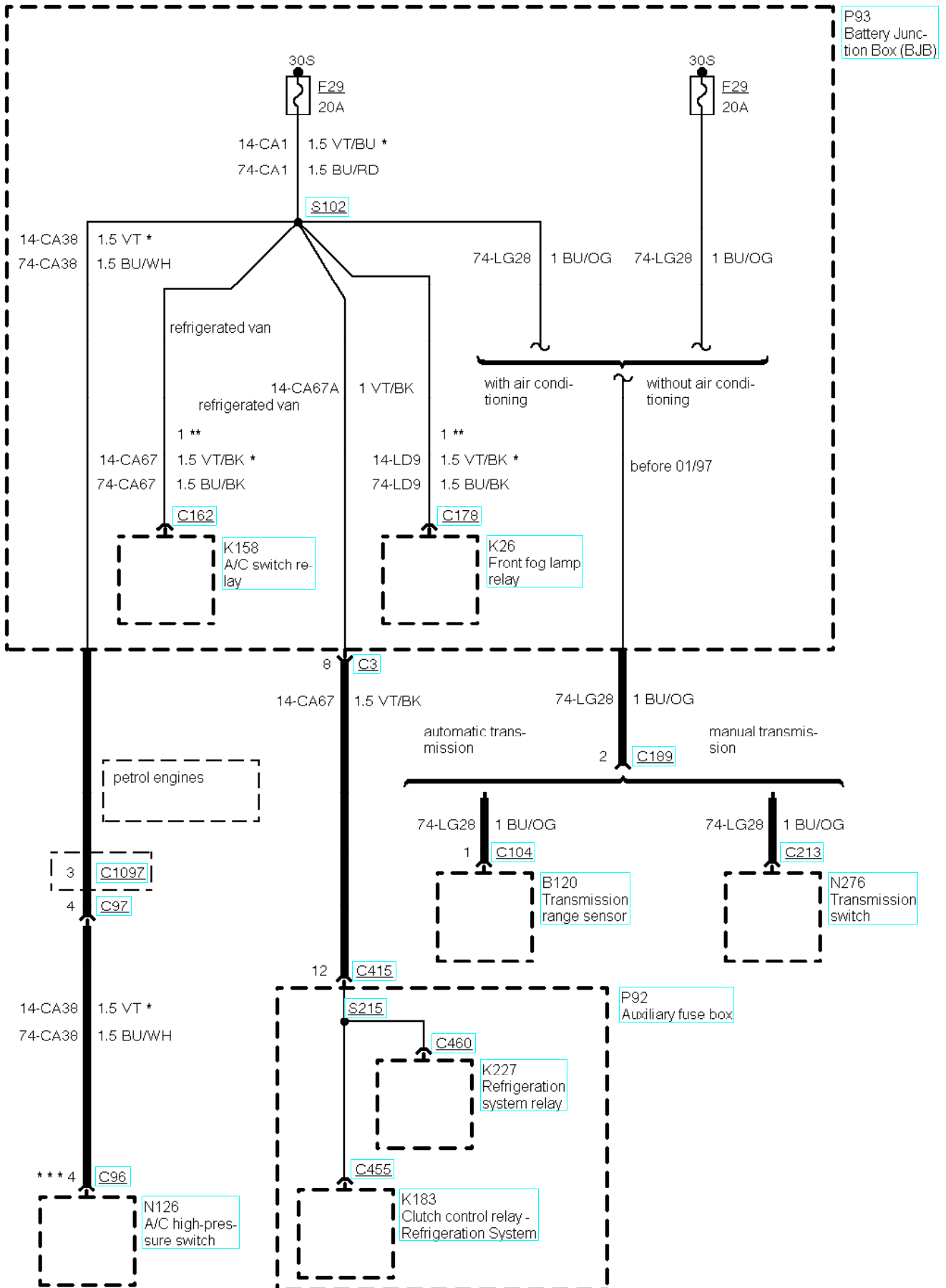

Fuses 30, 31 and 32

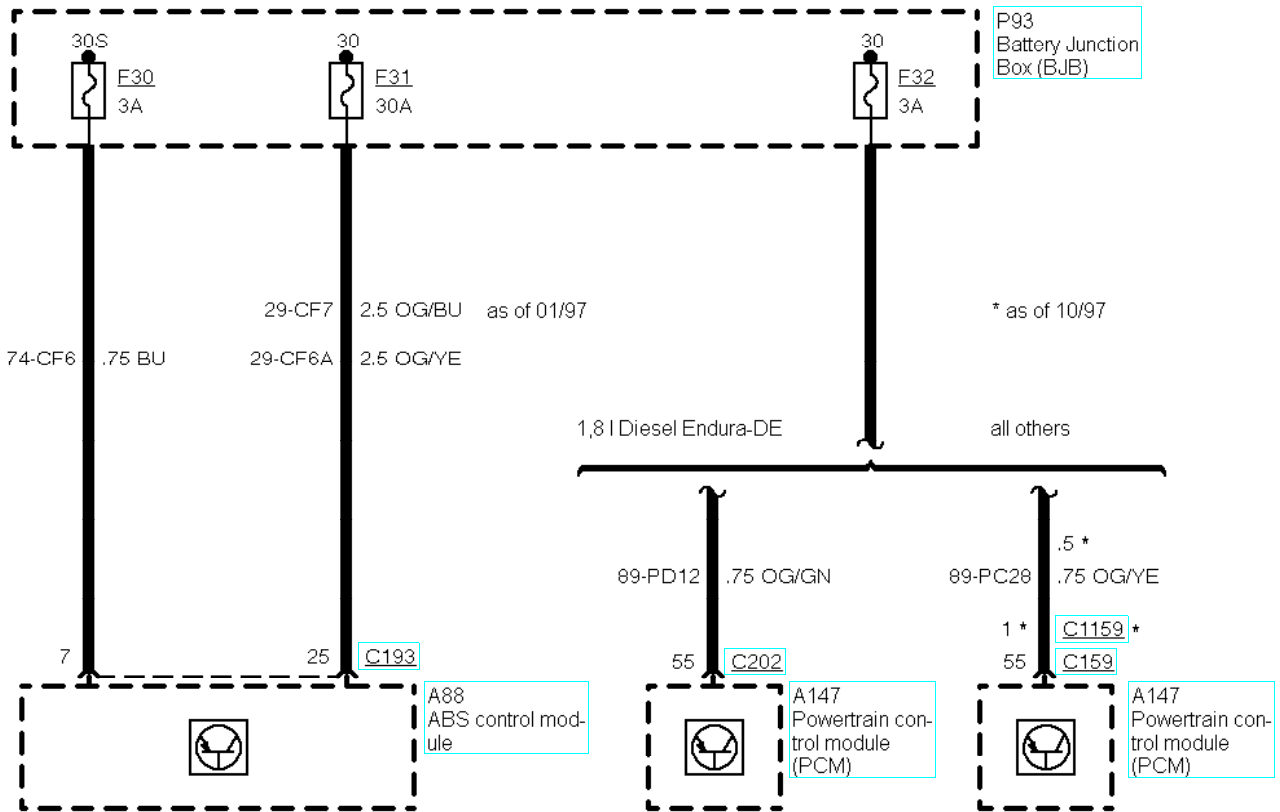

Fuse 33

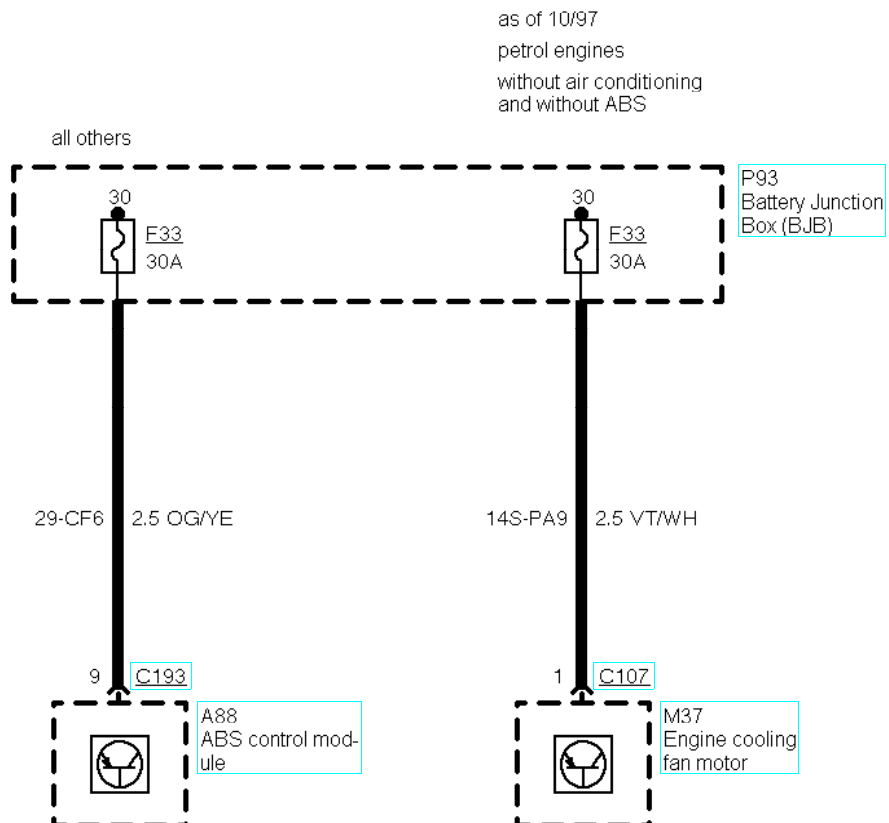

\* as of 10/97

\*\* high octane fuel

except 1,3 | Endura E as of 05/  
98 1,25 | ZETEC SE, manual  
transmission, as of 05/98

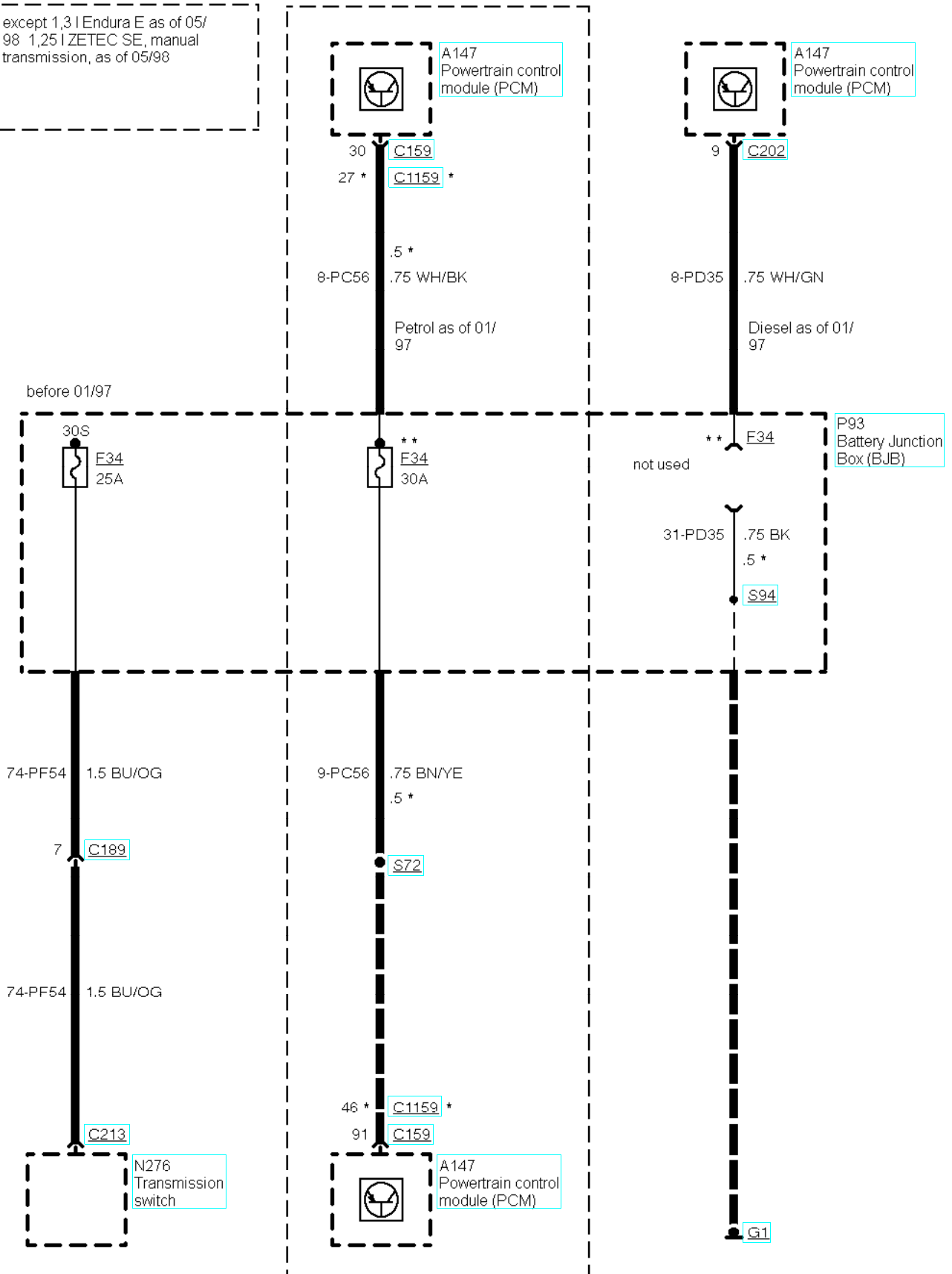



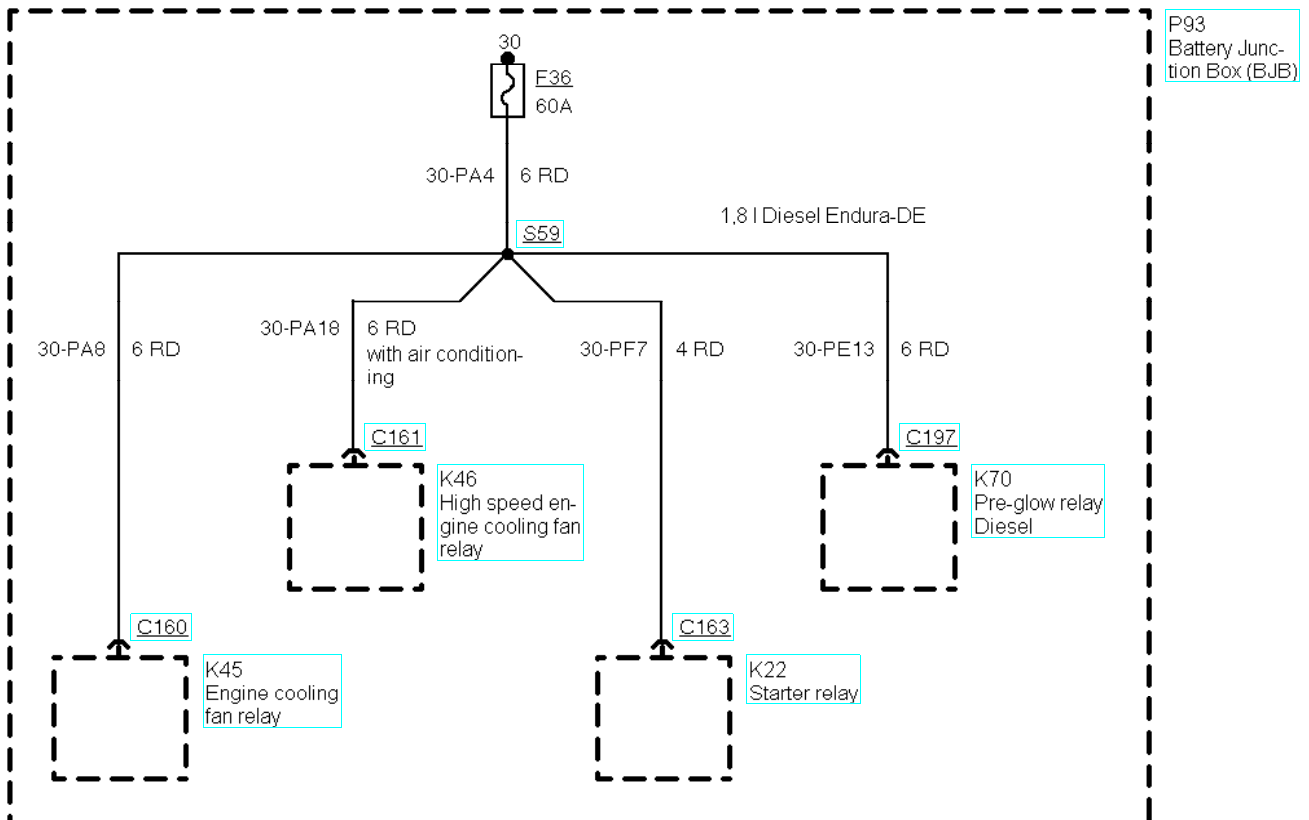
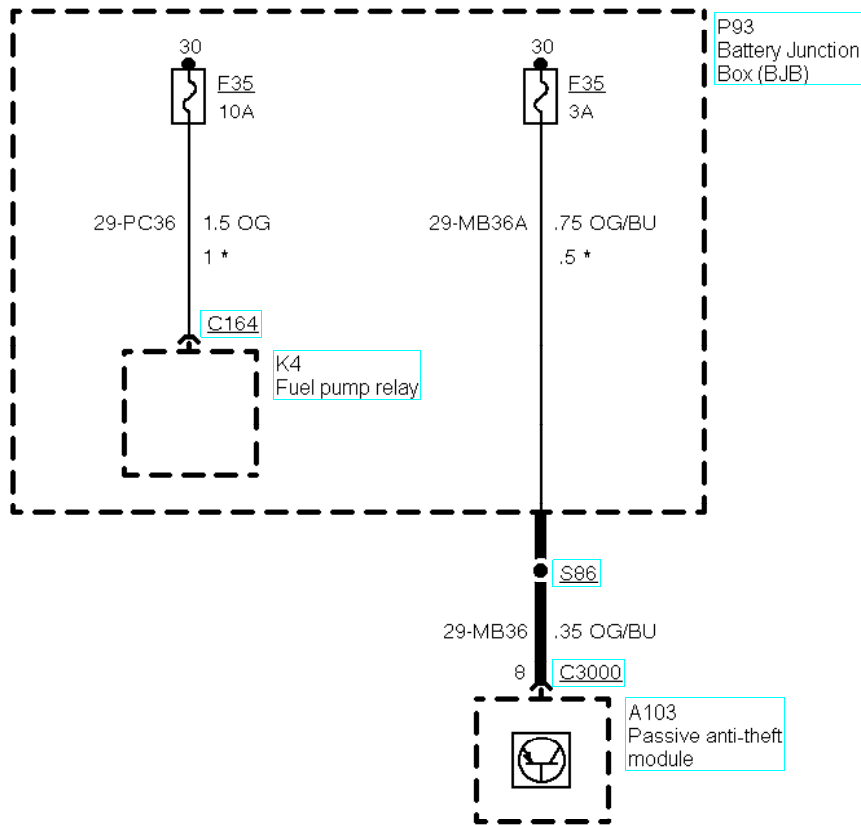

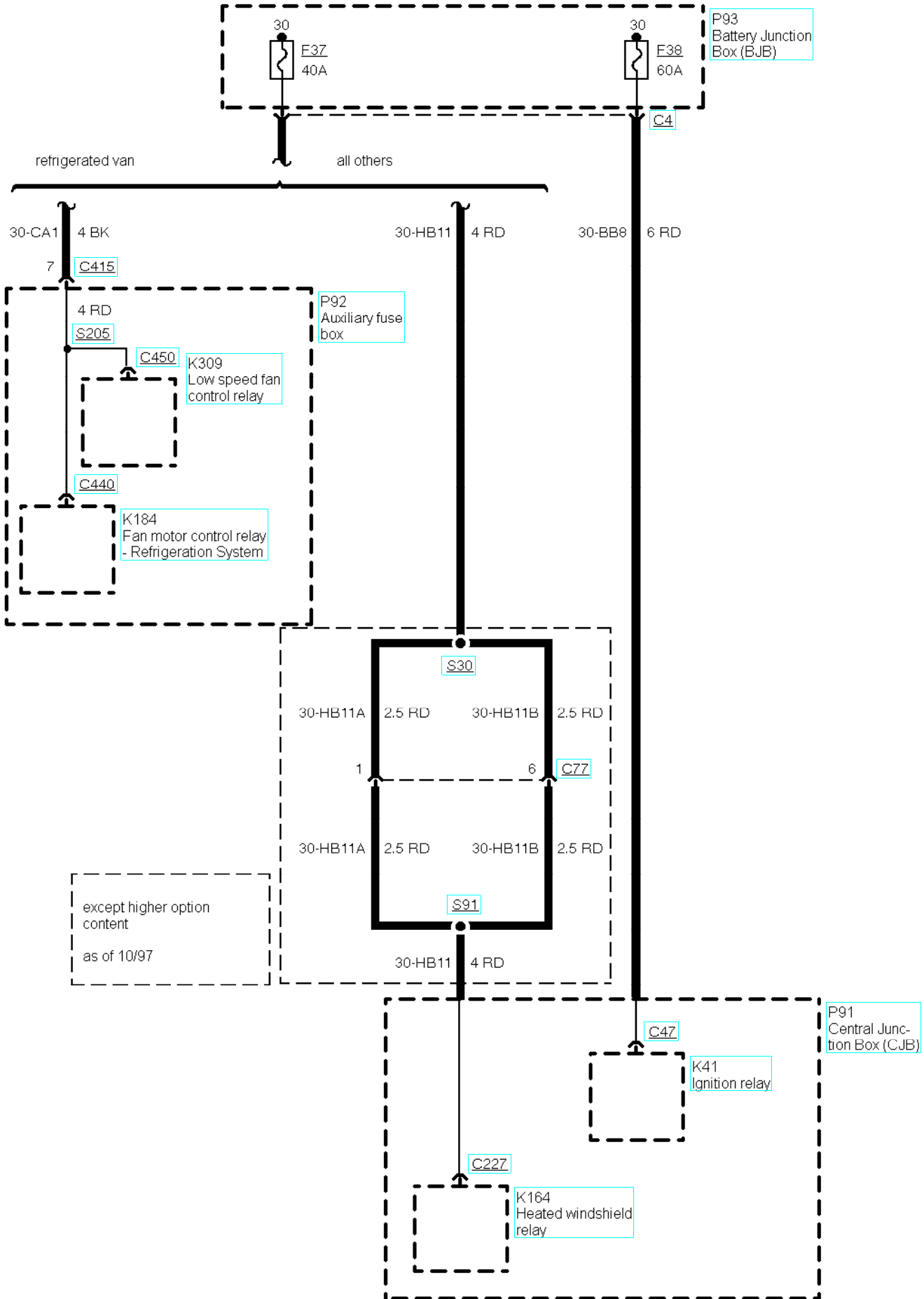

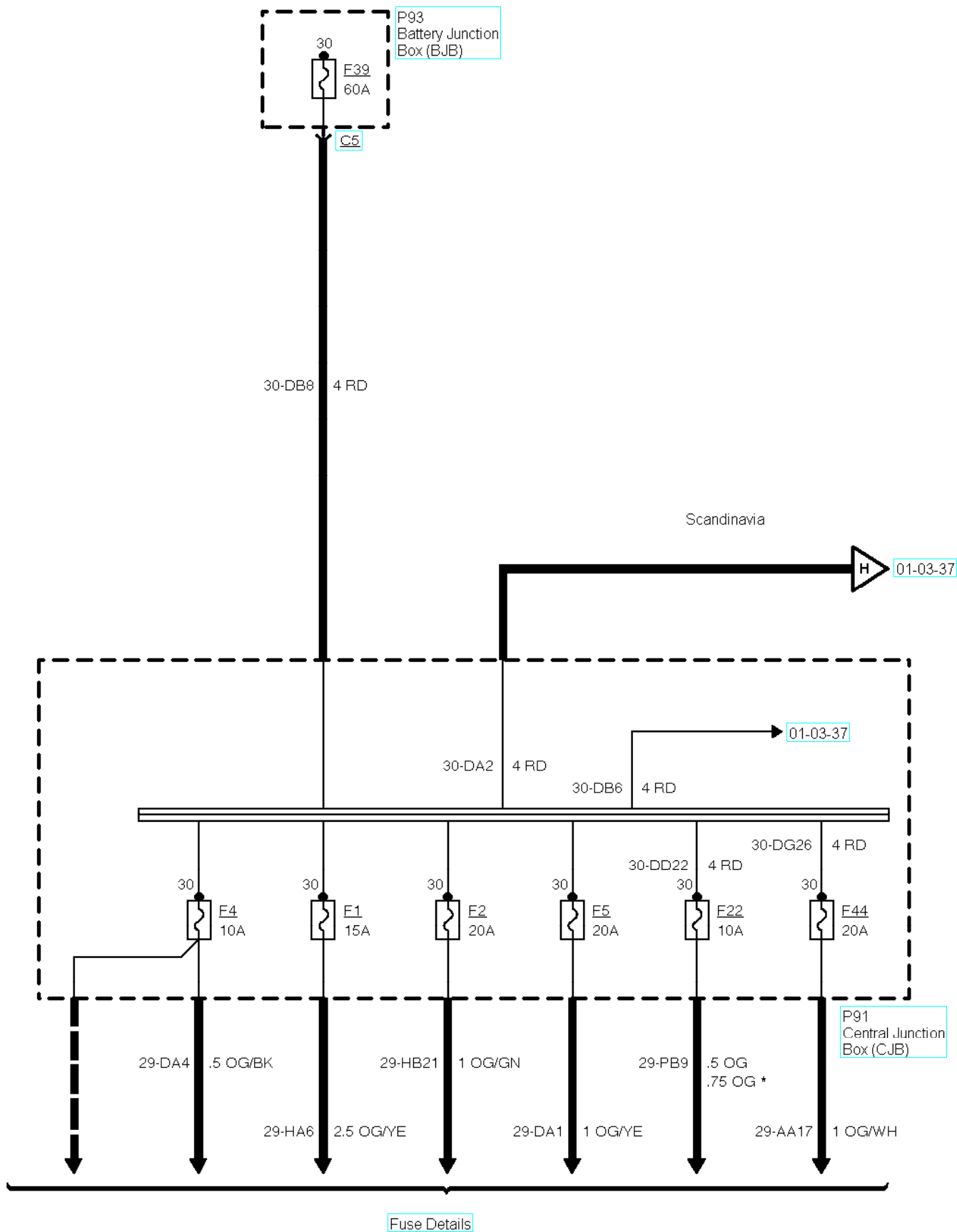

\* as of 03/96

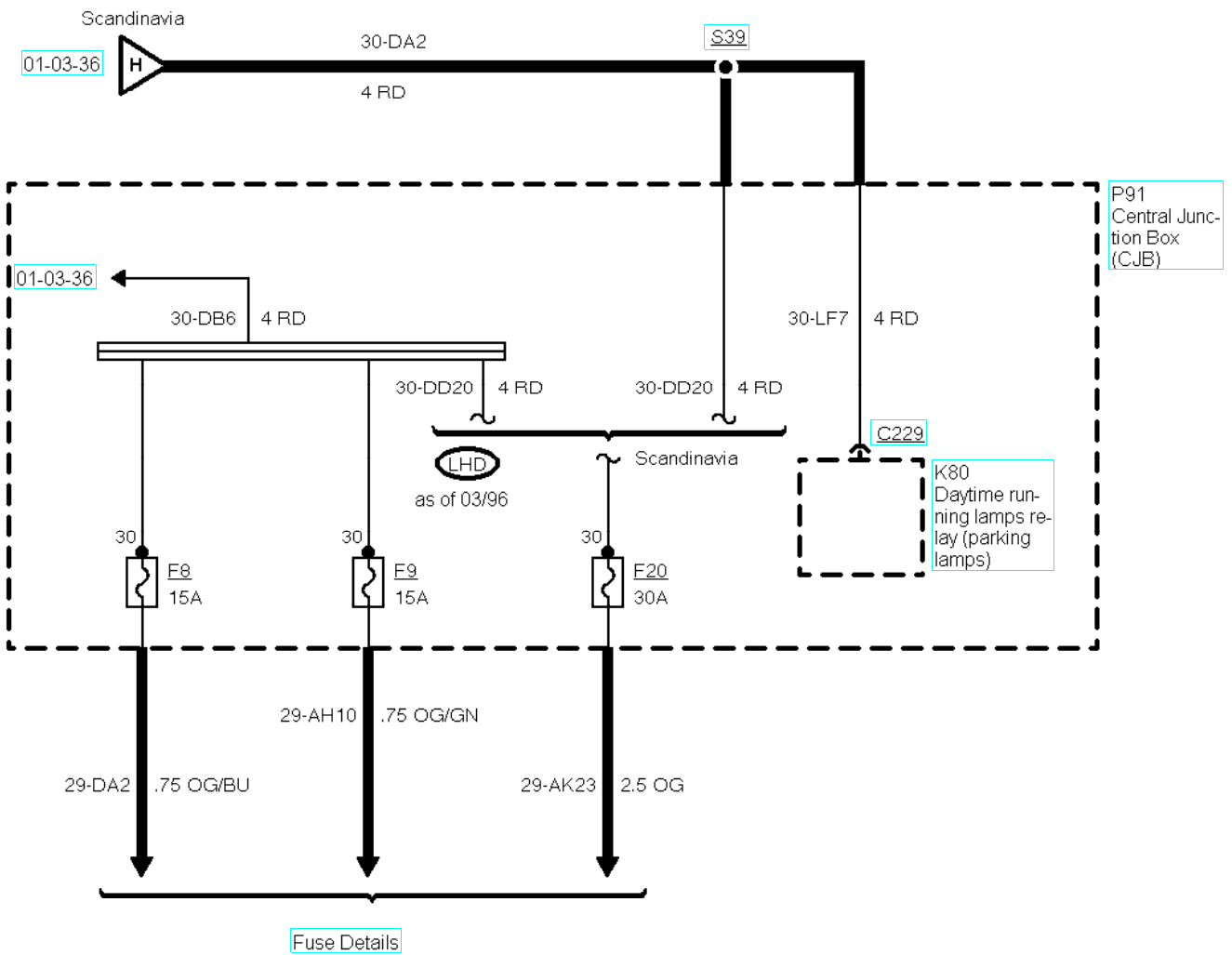
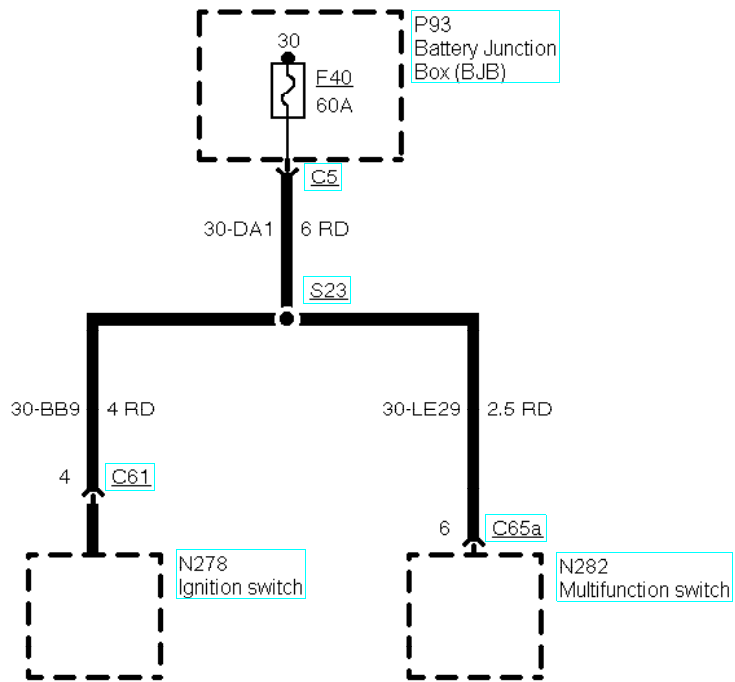

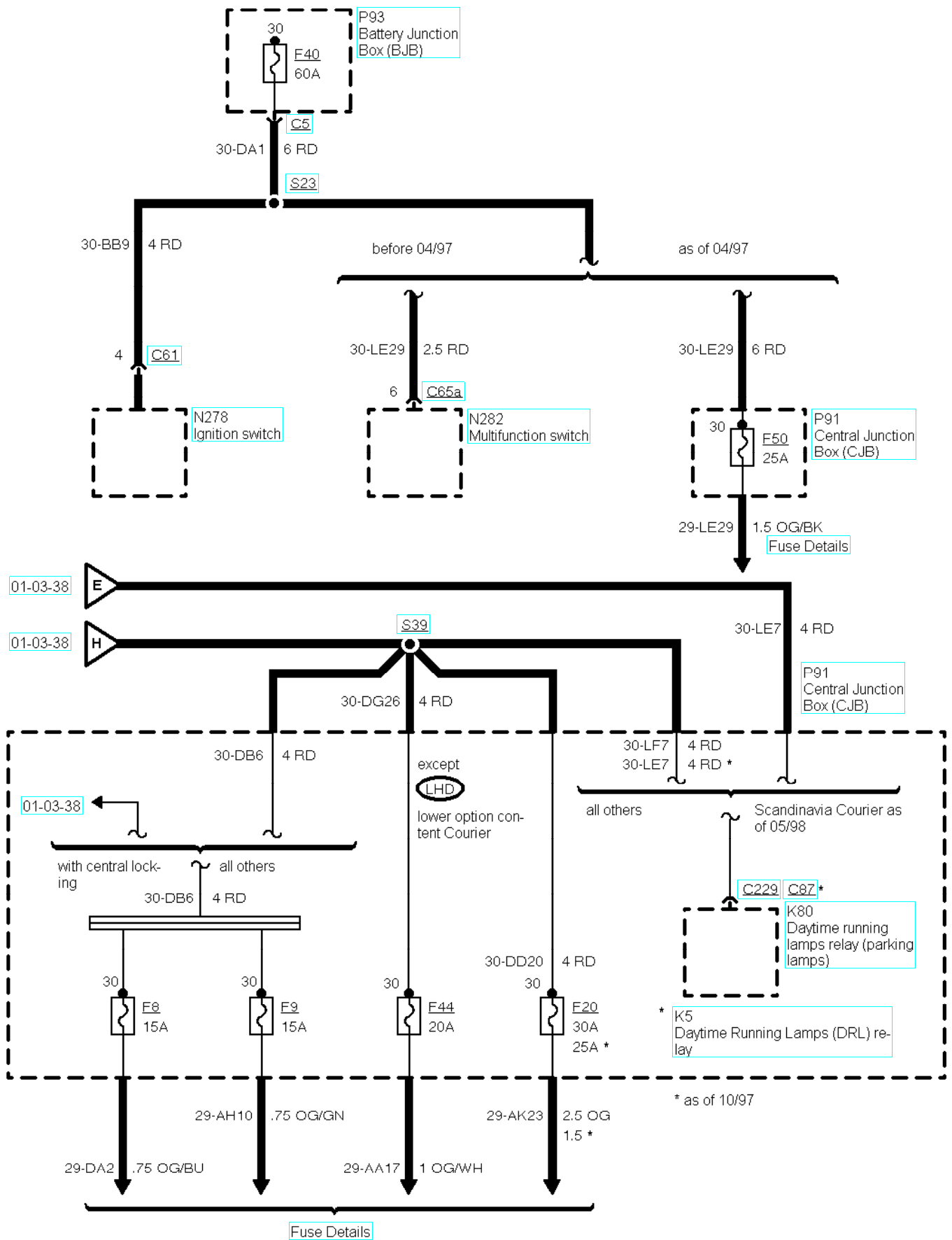

before 01/97 Courier and



Rear fog lamps only lower option content

as of 10/97 Courier

all others

as of 01/97 LHD Courier

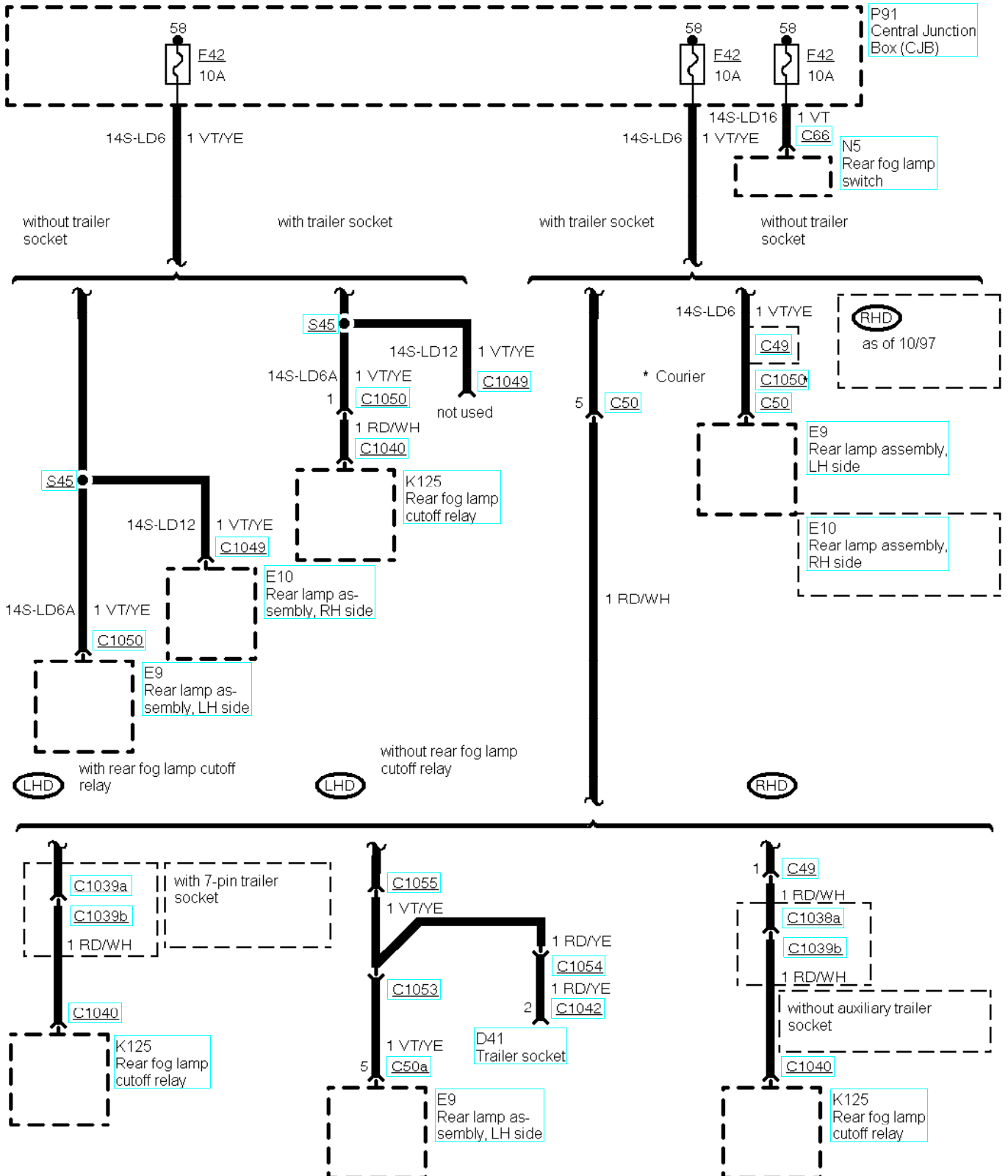

Fuses 43 and 44

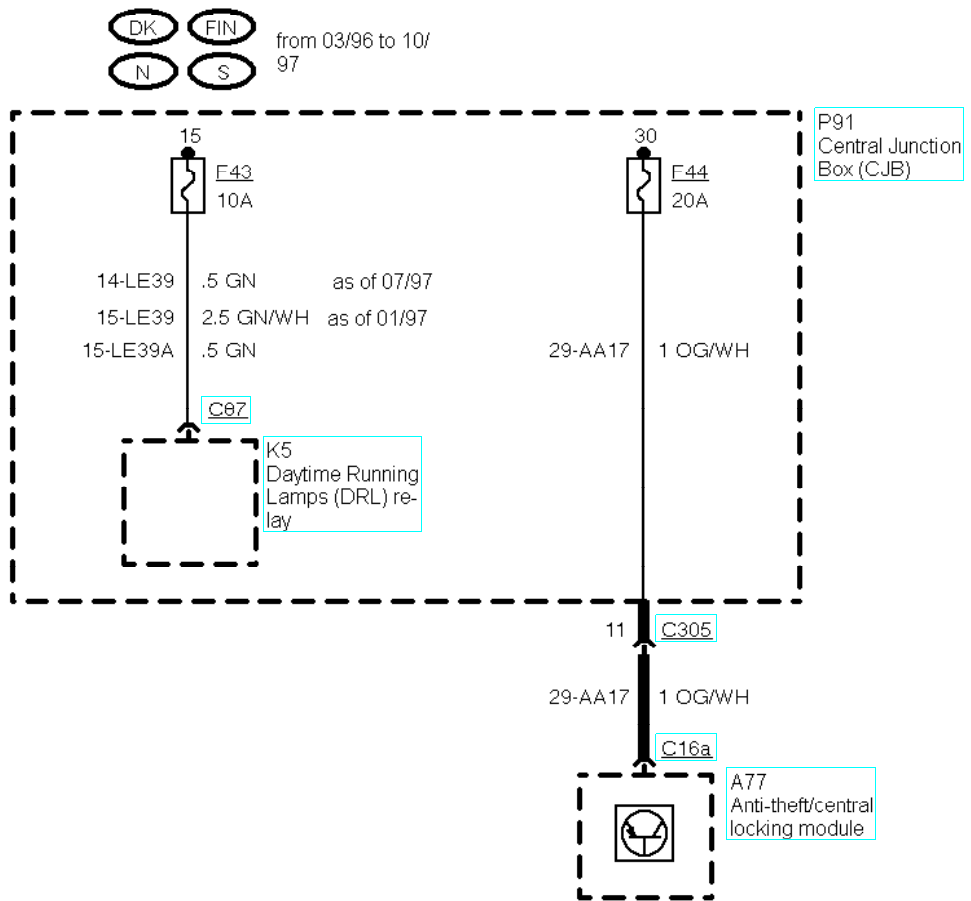

Fuse 45, Central locking

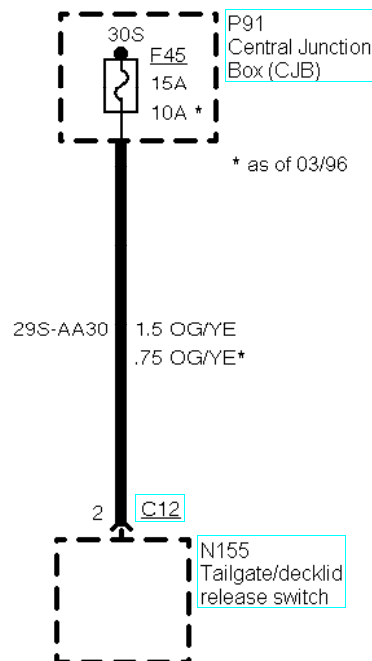

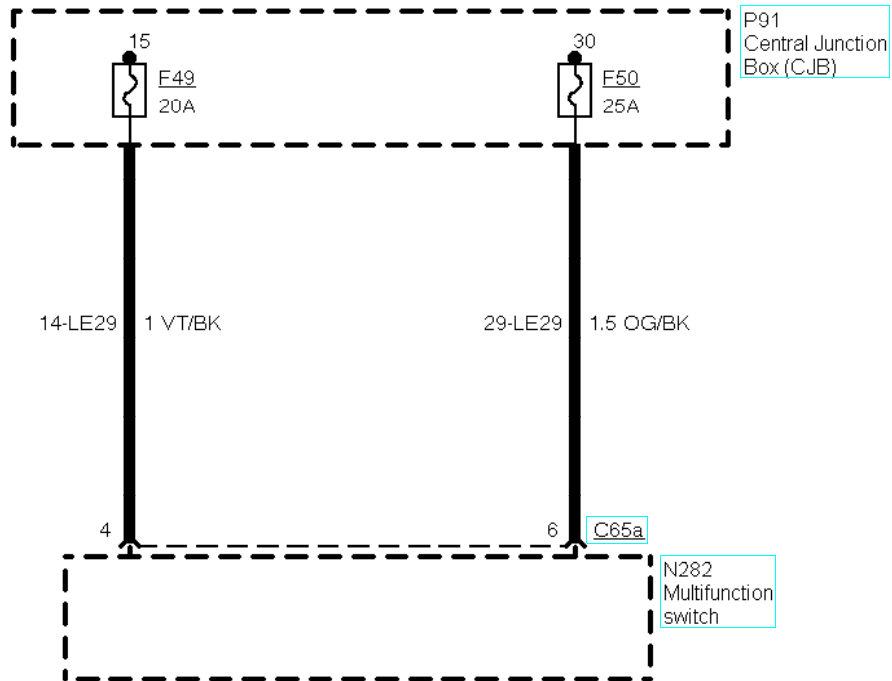



dealer-fitted

