

VOSA

Vehicle & Operator Services Agency

The Single Vehicle Approval Inspection Manual

Explanatory notes on the procedure and standards applicable
to vehicles requiring a Minister's Approval Certificate

VOSA

Vehicle & Operator Services Agency

The Single Vehicle Approval Inspection Manual

SIXTH AMENDMENT

The Vehicle and Operator Services Agency
PO Box 12
Swansea
SA1 1BP

March 2004

UPDATING SERVICE

The Single Vehicle Approval Inspection Manual

For convenience your details can be placed on a register from which we will notify you of any update that is to be issued, and its cost, so that you can apply for a copy if required.

If you wish to take advantage of this service, please complete the cut-off portion and return it to:

The Vehicle and Operator Services Agency
PO Box 12
Swansea
SA1 1BP

UPDATING SERVICE

The Single Vehicle Approval Inspection Manual

Please add my details to the update register. I understand that I will be notified automatically when an update is available.

Please complete in BLOCK CAPITALS

Name:

Address:

.....

Post Code:

Signature:

Position:

Tel No:

Written by the Vehicle & Operator Services Agency (formerly the Vehicle Inspectorate)

The Vehicle & Operator Services Agency (VOSA) was created on 1st April 2003 by merging the former Vehicle Inspectorate and the Traffic Area Network Division of the Department for Transport

© Crown copyright 1996

Applications for reproduction should be made to the VOSA

First published 1996

Revised December 1997

May 1998

May 1999

June 2000

December 2000

March 2004

ISBN 0 11 552476 2

Contents

Section	Page No	Issue	Section	Page No	Issue	
Foreword	5,6,7,8,9,	Mar 2004	6	Interior Fittings	1,2,3,4, 1,	Mar 2004 Dec 96
ENHANCED REQUIREMENTS			Exterior			
General	1,	Mar 2004	7*	Radio Suppression	1,	Dec 2000
E1 Anti-Theft Device	1,	Mar 2004	8	Glazing	1,2,3,	Mar 2004
E5a Seat Belt Anchorages	1,2,3,	Mar 2004	9.1	Lighting/Signalling (obligatory)	1-6,	Mar 2004
E5b Seat Belt Installation	1,2,3,4,5,	Mar 2004		Annex 1: Req. for Obligatory Lamps	1,	June 2000
Annex 1: Seat Belt Installation Requirements	1,	Mar 2004		Annex 2: Horizontal Angles of Visibility	2,	Mar 2004
Annex 2: Additional Information	1,	Mar 2004		Annex 3: Vertical Angles of Visibility	1,	May 99
E14a Protective Steering	1,2	Mar 2004		Annex 4: Measurement of Angles of Visibility	1,	Dec 97
E14b Frontal Impact	1,	Mar 2004		Annex 5: Lamp Apparent Surface	1,	May 99
E14c Side Impact	1,2,	Mar 2004		Annex 6: Definition – to the rear	1,	Mar 2004
E16* Brakes	1,2,3,4,	Mar 2004		Annex 7: Lamps in close proximity	1,	Mar 2004
Annex: Brake Performance	1,	Mar 2004	9.2	Lighting/Signalling (optional)	2,	Dec 2000
E17* Noise	1,2,	Mar 2004		Annex: Requirements for Optional Lamps	1,3, 1,	Mar 2004 Dec 96
E18a* Emissions	1,	Mar 2004			2,	Dec 97
E18b CO2/fuel consumption	1,	Mar 2004	9.3	Aim of Headlamps	2,3,4, 1,	Dec 97 Dec 2000
Annex 1: Requirements/Comparable Standards	1-15,	Mar 2004	10	Mirrors	3,4, 1, 2,	June 2000 Dec 2000 Mar 2004
Annex 2a: Immobiliser Requirements	1,2,	Dec 2000		Annex 1: Alternative Criteria for Motor Ambulances /Motor Caravans 3501kg - 7500kg GVW	1,	June 2000
Annex 2b: Alarm System Requirements	1,2,	Dec 2000		Annex 2: Mirror Field of View Check	1,	Dec 97
STANDARD REQUIREMENTS				Annex 3: Alternative Test Procedure	1,2,3,4,	Mar 2004
Annex: Non-European Standards	1,2,3,	Mar 2004	11	Tyres	3, 1,2, 4,	Dec 96 May 98 June 2000
Interior				Annex 1: Speed Categories	1,	Dec 2000
1 Anti-theft Device	1,	Mar 2004		Annex 2: Tyre Capacity Tables (Ply Rated)	1,	Dec 96
2 Defrosting/Demisting	1,	Mar 2004		Annex 3: Tyre Capacity Tables (Load Index)	1,	Dec 96
Annex: Windscreen “Horizontal Plane”	1,	June 2000		Annex 4: Calculation of Maximum Axle Weight	1,	June 2000
3 Windscreen Wipers and Washers	2,	Dec 96	12	Doors, Latches, Hinges	1,2,	Mar 2004
	1,	Dec 2000				
4 Seats and Anchorages	1,	Mar 2004				
5 Seat Belts and Anchorages	1-8,	Mar 2004				
Annex 1: Anchorage Strength Assessment	1,3, 2,4-9,	Dec 96 Mar 2004				
Annex 2: Obligatory Requirements	1,2	Mar 2004				
Annex 3: Additional Information	1,	Mar 2004				
Annex 4: Upper Anchorage Location	1,	Dec 96				
	1,2,	Dec 2000				

NOTE: All items are applicable to Passenger Vehicles, but only the items marked “*” are applicable to Goods Vehicles.

Contents

Section	Page No	Issue
13 Exterior Projections	1-7,	Mar 2004
Annex 1: Vehicle Assessment	1-6,	Mar 2004
Annex 2: "Floor Line"	1,	Mar 2004
Underside		
14* Protective Steering	3,4,5,	Dec 96
	1,2,	Mar 2004
Annex: Vehicle Assessment	1,2,	Dec 96
	3,	Dec 2000
15.1* Vehicle Design and Construction	1,2,3,4,	Mar 2004
15.2* Vehicle Design and Construction	1,2,	Mar 2004
16.1* Brakes (Systems)	2,	Dec 96
	1,	Mar 2004
16.2* Brakes (Service controls)	3,4,	Dec 96
	1,2,	Mar 2004
16.3* Brakes (Parking controls)	1,2,	Mar 2004
16.4* Brakes (Hydraulic & Vac)	2,	Dec 96
	3,5,	Dec 97
	1,2,4	Mar 2004
16.5* Brakes (Brake Performance)	1-10,	Mar 2004
Annex: Brake Performance	2,	May 98
	1,	June 2000
Specific Tests		
17* Noise	2,	Dec 2000
	1,	Mar 2004
18* Emissions (Spark Ignition)	1-14,	Mar 2004
19* Emissions (Diesel)	1,2,3,	Mar 2004
20 Speedometer	1,2,	Mar 2004
21 Design Weights	3,	Dec 96
	1,2,	Dec 2000
Annex: Weight Calculations	1,	Dec 96
22* Manufacturer's Plate	1,2,	Mar 2004
Glossary of Terms	1,2,	Mar 2004

NOTE: All items are applicable to Passenger Vehicles, but only the items marked "*" are applicable to Goods Vehicles.

1. Foreword

This Manual is a detailed guide on the inspection of vehicles submitted to an official testing station under the Single Vehicle Approval (SVA) scheme.

It is produced for the examiners who carry out the inspections and for vehicle presenters and other interested parties who wish to familiarise themselves with the technical requirements and inspection procedures.

2. Application

The Single Vehicle Approval scheme applies to

a. Passenger and Dual Purpose Vehicles with

- four or more wheels and not more than eight seats in addition to the driver's seat.
- three wheels and not more than eight seats in addition to the driver's seat and a maximum gross weight of more than 1000kg.
- three wheels and a maximum gross weight not more than 1000kg and an unladen weight of more than 410kg (ie not a motorcycle) and either
 - a design speed exceeding 50km/h (31mph), or
 - an engine capacity exceeding 50cc.

NOTE 1: Where a vehicle is fitted with seats that do not have seat belts, eg. side or rear facing seats, the number of seating positions for those seats should be obtained by the summation of seating positions for each seat, obtained by dividing the width of each seat base cushion by 400mm.

NOTE 2: A "seating position" is where there is provision for a seat due to the presence of seat anchorage points.

b. Goods Vehicles (including tractor units of articulated vehicles) with;

- three or more wheels, and
 - a design gross weight not more than 3500kg
- or
- three or more wheels, and
 - a design gross weight more than 3500kg but not more than 5500kg, and
 - down-plated to a design gross weight of 3500kg, and
 - a kerbside weight not more than 3425kg, and
 - belonging to the same family of types as at least one vehicle granted a Minister's Approval Certificate under the above goods or passenger categories.

NOTE: "Family of types" means, of the same manufacturer, the same basic chassis/floor pan, and the same power plant e.g. Internal Combustion/Electric/Hybrid.

c. Motor Caravans and Ambulances

3. Obligatory Minister's Approval Certificates

In order to obtain a licence and be registered for the first time in the UK, all the classes of vehicle mentioned in item 2 will need to obtain a Minister's Approval Certificate (MAC) except the following

- Motor Caravans
- Motor Ambulances
- a vehicle which has been issued with a Minister's Approval Certificate under GB National Type Approval
- a vehicle which has been issued with an EC certificate of conformity
- a vehicle which has been issued with a Minister's Approval Certificate on the basis that it has been suitably approved and registered in another EEA member state
- a vehicle which is at least 10 years of age
- a vehicle used by a member of a "visiting force".

The MAC may either be issued as a result of satisfying the requirements of the Approval regulations (Single Vehicle Approval), or in the case of a passenger or dual purpose vehicle, by satisfying the requirements of the Motor Vehicles (Type Approval) (Great Britain) Regulations 1984, or in the case of a goods vehicle or tractor unit, by satisfying the requirements of the Motor Vehicles (Type Approval for Goods Vehicles) (Great Britain) Regulations 1982.

NOTE 1: For a precise legal definition of vehicles to which the Approval regulations apply, see regulation 4 of the Approval regulations.

NOTE 2: For a precise legal definition of which vehicles require a MAC before they can be registered, see regulation 14 of the Approval regulations.

Foreword

4. Approval Process

There are two parts to the Approval process. The first part “the Enhanced Requirements” only applies to certain vehicles, in general, those imported on a commercial basis that do not align to one of the definitions “a” to “j” listed on pages 7 to 9 of this section of the manual.

The standards applicable are those given in Annex 1 to the “Enhanced Requirements” section of this manual, and are dependent on the date of manufacture of the vehicle.

The onus is on the applicant to provide evidence of compliance. This can, for example, be in the form of manufacturer’s markings on the vehicle, documentary evidence from the competent authority in the country of origin or the manufacturer, submission of a test report from an accredited testing authority or a combination of such elements, and it may also include a degree of visual examination and practical tests.

Applications and supportive documentation will be assessed prior to the issue of an appointment. Examination of the vehicle will include verification checks to confirm as far as possible compliance with the required standards.

The second part “the Standard Requirements” are applicable to all vehicles other than in respect of a class “R” vehicle where the requirements in respect of Protective Steering, Emissions (item 18 only), Seat Belt Anchorages (other than in the case of a “Disabled Person’s Vehicle”)

and Noise will not apply if the vehicle has been found to meet the ESVA requirements for these items.

The examination criteria for this part of the process is contained in the ‘Standard Requirements’ sections 1 to 22 of this manual.

5. Scope of inspection

The design and construction requirements applicable to any particular vehicle are contained in The Motor Vehicles (Approval) Regulations 2001 as amended (the Approval Regulations). The inspection procedures within this manual have been developed to assess as far as practicable the ability of the vehicle to comply with the requirements. This manual is not a legal interpretation of the Regulations.

The issue of a Minister’s Approval Certificate should not be taken as absolute evidence that the vehicle complies with the Approval Regulations or that the vehicle can legally be used on the road because, for example, the requirements relate only to construction, not condition, however, the Approval Regulations are compatible with the construction requirements of The Road Vehicles (Construction and Use) Regulations and The Road Vehicles Lighting Regulations and wherever practicable applicants will be advised if their vehicle is likely to be in breach of these regulations.

NOTE: The vehicle will be assessed for compliance in all modes of operation unless otherwise specified, for example

- in the case of a convertible vehicle, with the hood up and with the hood down.

- if dual fueled, when running on each separate fuel source.

- if fitted with a remote engine air/fuel ratio adjustment device in minimum/maximum positions.

6. Refusal to examine

The examination of a vehicle may be refused for any of the following reasons

- the vehicle is not submitted for examination at the time and place appointed
- the fee has not been paid
- the vehicle cannot be driven or has insufficient fuel or oil to enable the test to be completed
- the vehicle is presented in a dirty or dangerous condition such as to make it unreasonable for the examination to be carried out
- a load or items on the vehicle are not secured or removed as requested
- a proper examination cannot be carried out because any door, tailgate, boot lid, engine cover, fuel cap or other device designed to be readily opened cannot be opened
- the condition of the vehicle (in the opinion of the examiner) is such that proper examination of the vehicle would involve a danger of injury to any person or damage to the vehicle or any other property

- the vehicle does not display, permanently, in an accessible position and readily legible, the required vehicle identification number
- the driver does not remain in the vehicle or its vicinity and operate the controls, drive the vehicle or to remove/refit panels as requested.

7. Method of Inspection

The examination will be limited to parts of the vehicle which can be readily seen without dismantling, however, the driver might be required to open lockable compartments and remove engine covers, inspection/access panels, trims or carpeting, etc in order to gain access to items subject to examination.

The visual assessment of certain items eg seat belt anchorages (which in Type Approval undergo a physical test) might not always be sufficient to satisfy the examiners that the vehicle complies with the requirements of the regulations. In such circumstances the onus is on the applicant to demonstrate, for example, by the production of satisfactory test result documentation, that the vehicle complies with the requirements of the regulations.

This is unlikely to be required in the case of "production" vehicles which are known to comply with recognised international standards.

In some areas of the test, evidence that the vehicle complies with the relevant criteria may be submitted in the form of documentation. This can, for example, be satisfactory evidence that the vehicle complies with the relevant requirements of

a European Directive or compliance with one of the "non-European" National Standards listed in the annex to this section.

8. Use of this manual

The sections of the manual have been split into four groups. Each group broadly covers an area of examination, ie interior, exterior, underside and specific tests, although there may be a large degree of overlap in certain subjects, eg brakes.

Each section is divided into three parts

Application - indicating the vehicles to which this section of the manual applies and any exemptions that may be applicable.

Procedure and Standards - listing the test procedures and the standards that are required.

Reasons for Failure - giving the reasons why the issue of a Minister's Approval Certificate may be refused. This part should be read in conjunction with the Procedure and Standards.

The sections marked with an asterisk are the only sections that apply to a goods vehicle.

NOTE: Motor Caravans, Motor Ambulances and Hearses are to be considered as "passenger vehicles" for the purpose of applying the test criteria.

9. Definitions

In this manual references are made to various vehicle "classes" and "categories", in brief these are:-

a. Personal Import

A vehicle is a personally imported vehicle if

- it has been imported by a person entering the United Kingdom (in the case of a serving member of the Armed Forces, is to be imported within 12 months of the date of application)
- that person, at the time the vehicle was imported (in the case of a serving member of the Armed Forces, at the time of application) had been normally resident in a country other than the UK for a continuous period of at least 12 months
- that person intends to become normally resident in the UK
- the vehicle has been in the possession of that person and used by him in the country where he has been normally resident for a period of at least 6 months before its importation, and
- it is intended for his personal or household use in the UK.

b. Amateur Built

A vehicle constructed or assembled for the personal use of an individual and

- the construction/assembly or a substantial part of it was carried out by the individual and/or other persons acting on his behalf, and
- the individual/other persons acting on his behalf during the period of construction/assembly did not have a business in which motor vehicles are normally constructed/assembled.

Foreword

c. Vehicles manufactured using parts of a registered vehicle

A vehicle that

- is constructed or assembled by a person carrying on a business in the course of which motor vehicles are normally constructed or assembled
- is equipped with an engine which has previously been used as the engine of another vehicle which had been registered under the Vehicle Excise and Registration Act 1994 or any earlier Act relating to the registration of mechanically propelled vehicles, and
- is equipped with one or more of the following components taken from the same vehicle as the engine
 - chassis
 - body
 - suspension
 - an axle
 - transmission
 - steering assembly.

d. Very Low Volume

A vehicle which either

- is of a family of types of which the total number manufactured in the world for any 12 months falling within the period of 36 months immediately before the month in which the vehicle was manufactured does not exceed 200.

NOTE: “family of types” means, of the same manufacturer, of the same basic chassis/floor pan, and the same power plant e.g. Internal Combustion/Electric/Hybrid, or

- is of a type variant of which the total number manufactured in the world for any period of 12 months falling within a period of 36 months immediately before the month in which the vehicle was manufactured does not exceed 20.

NOTE: “type variant” is vehicles which do not differ in the following respects

- manufacturer
- essential aspects of construction and design in
 - the basic chassis, floor pan or other parts of the vehicle structure
 - the power plant (internal combustion, electric or hybrid)
- body style (e.g. saloon, hatchback, coupe, cabriolet or estate wagon)
- power plant
 - working principle (positive ignition, compression ignition and whether two stroke or four stroke)
 - number and arrangement of cylinders
 - maximum power by more than 30% (the highest is not more than 1.3 times the lowest)
 - engine capacity by more than 20% (the highest is not more than 1.2 times the lowest).

e. Motor Ambulance

A motor vehicle of category M (passenger vehicles) intended for the transport of sick or injured people and having special equipment for such purpose.

f. Motor Caravan

A special purpose M₁ category vehicle (vehicle having 8 or less passenger seats) constructed to include living accommodation which contains at least the following equipment.

- seats and table,
- sleeping accommodation which may be converted from the seats,
- cooking facilities, and
- storage facilities.

This equipment shall be rigidly fixed to the living compartment; however, the table may be designed to be easily removable.

g. Dual Purpose

A vehicle constructed or adapted for the carriage of both passengers and goods or burden of an unladen weight not exceeding 2040kg and

- is permanently fitted with a rigid roof (covering a common passenger/load compartment)

NOTE: Where the vehicle has two separate compartments for passengers and goods (possibly with separate roof structures) or the roof on the passenger area does not extend over the goods area, the vehicle is deemed to be a Goods Vehicle.
- the area to the rear of the driver’s seat
 - is permanently fitted with at least one row of transverse seats for two or more passengers which are sprung or cushioned with an upholstered backrest, and

Cont’d ▼

- is fitted on each side and at the rear with a window or windows of glazing material having an area or aggregate area of not less than 1850cm² on each side and 770cm² at the rear, and
 - the distance between the rearmost part of the steering wheel and the backrests of the rearmost row of seats is not less than one third of the distance between the rearmost part of the steering wheel and the rearmost part of the floor of the vehicle.
- h. Rebuilt Vehicle**
A vehicle that
- is a vehicle to which the Secretary of State is required by regulation to assign a vehicle identification number, and
 - does not fall within the definition of an “Amateur Built” vehicle or “Vehicle manufactured using parts of a registered vehicle,” and
 - has been rebuilt using a replacement chassis or integral chassis/body which is of the same design and construction as that of the original vehicle and which
 - was supplied for the purpose without having been previously used, or
 - previously formed part of a registered vehicle.

- i. Hearse**
A vehicle intended for the transport of deceased people and having special equipment for the purpose.
- j. Armoured Vehicle**
A vehicle intended for the protection of conveyed passengers and/or goods and complying with armour plating anti-bullet requirements.
- k. Disabled Person’s vehicle**
A vehicle which is adapted or constructed so as to enable a disabled person, to travel in it, whether as driver or as a passenger, in safety and reasonable comfort (“disabled person” means a person who has a disability as defined in section 1 of the Disability Discrimination Act.)
- l. Category M:**
Motor vehicles with at least four wheels used for the carriage of passengers.
- M1:** Vehicles used for the carriage of passengers and comprising no more than eight seats in addition to the driver’s seat.
- M2:** Vehicles used for the carriage of passengers, comprising more than eight seats in addition to the driver’s seat, and having a maximum mass not exceeding 5 tonnes.
- M3:** Vehicles used for the carriage of passengers, comprising more than eight seats in addition to the driver’s seat, and having a maximum mass exceeding 5 tonnes.

- m. Category N:**
Motor vehicles with at least four wheels used for the carriage of goods.
- N1:** Vehicles used for the carriage of goods and having a maximum mass not exceeding 3,5 tonnes.
- N2:** Vehicles used for the carriage of goods and having a maximum mass exceeding 3,5 tonnes but not exceeding 12 tonnes.
- N3:** Vehicles used for the carriage of goods and having a maximum mass exceeding 12 tonnes.
- NOTE:** Precise legal definitions can be obtained from The Motor Vehicles (Approval) Regulations 2001, as amended, other than in the case of “Dual Purpose Vehicle” which is defined in The Motor Vehicles (Type Approval) (Great Britain) Regulations 1984 as amended, and vehicle “categories” which are defined in European Directive 70/156/EEC as amended.

Application	Procedure and Standards	Reasons for Failure
<p>All vehicles except</p> <p>a) Goods vehicles in respect of items E1, E5a, E5b, E14a, E14b, E14c, and E18b only.</p> <p>b) the following classes</p> <ul style="list-style-type: none"> ▪ a left hand drive vehicle, ▪ a personal import, ▪ an amateur built vehicle, ▪ a vehicle manufactured in very low volume, ▪ a vehicle manufactured using parts of a registered vehicle, ▪ a rebuilt vehicle, ▪ a motor ambulance, ▪ a motor caravan, ▪ a hearse, and ▪ an armoured vehicle, <p>NOTE 1: Any unregistered vehicle which is one of the above classes can be submitted for a statutory ESVA on a voluntary basis.</p> <p>NOTE 2: For definitions see Foreword item 9.</p>	<p>The vehicle must comply with the requirements of Regulation 5 (and the specific requirements of schedule 4) of the Motor Vehicles (Approval) Regulations 2001.</p> <p>These requirements are based on European Directives or Regulations although evidence of compliance with alternative non-European standards are acceptable where they are in practice considered to provide comparable standards. The required standards are age related and apply to the following items:-</p> <p>E1) anti-theft device (date of man. 1/10/98-on) E5a) seat belt anchorages (date of man. 1/07/91-on) E5b) installation of seat belts (date of man. 1/07/97-on) E14a) protective steering (date of man. 1/07/91-on) E14b) frontal impact (date of man. 1/10/2003-on) E14c) side impact (date of man. 1/10/2003-on) E16) brakes (date of man. 1/04/95-on) E17) noise and silencers (date of man. 1/07/91-on) E18a) exhaust emissions (date of man. 1/01/93-on) E18b) CO2 /fuel consumption (date of man. 1/01/97-on)</p> <p>See Annex 1.</p> <p>NOTE: The initial assessment of compliance will be carried out on the documentation provided to support the application submitted to the VOSA technical centre.</p> <p>Examination of the vehicle will include the checking of details specific to the individual vehicle and its alignment with any documentation provided in support of its compliance with the standards required.</p>	

Anti-theft Device E1

Application	Procedure and Standards	Reasons for Failure
<p>All vehicles except</p> <ul style="list-style-type: none">a. Goods vehiclesb. Three wheeled vehiclesc. Passenger vehicles having a date of manufacture before 1 October 1998d. those not subject to ESVA ie<ul style="list-style-type: none">▪ a left hand drive vehicle▪ a personal import▪ an amateur built vehicle▪ a vehicle manufactured in very low volume▪ a vehicle manufactured using parts of a registered vehicle▪ a rebuilt vehicle▪ a motor ambulance▪ a motor caravan▪ a hearse, and▪ an armoured vehicle. <p>NOTE: For definitions see "Foreword" item 9.</p>	<p>1. Check that the vehicle is accompanied by satisfactory documentary evidence of compliance with the requirements of item E1 listed in the "Enhanced SVA Requirements" Annex.</p> <p>NOTE: The vehicle must comply with the requirements appertaining to the installation of an immobiliser. If an alarm is fitted evidence of compliance in respect of the alarm is also required.</p>	<p>1. The vehicle is not accompanied by satisfactory evidence of compliance with the required standard in respect of the "Anti-theft" device(s).</p>

Seat Belt Anchorages E5a

Application	Procedure and Standards	Reasons for Failure																								
<p>All vehicles except</p> <ol style="list-style-type: none"> Goods vehicles. Three wheeled vehicles. Disabled Person's vehicles, <ul style="list-style-type: none"> manufactured as a category M1 vehicle and adapted after the time of manufacture by the installation of an anchorage, where the requirements of items 2 & 3 only will apply to that anchorage. <p>NOTE: Evidence of compliance in respect of the other anchorages is required.</p> <ul style="list-style-type: none"> adapted to an M1 category vehicle from a goods vehicle or a passenger vehicle with more than 8 passenger seats, where the requirements of items 2 & 3 only will apply to all seating positions. <ol style="list-style-type: none"> those not subject to ESVA ie <ul style="list-style-type: none"> a left hand drive vehicle a personal import an amateur built vehicle a vehicle manufactured in very low volume a vehicle manufactured using parts of a registered vehicle <p style="text-align: right;">Cont'd ▼</p>	<ol style="list-style-type: none"> Check that the vehicle is accompanied by satisfactory documentary evidence of compliance with the requirements of item E5a listed in the "Enhanced SVA Requirements" Annex. <p>NOTE: Evidence of compliance may be in the form of vehicle specific documentary evidence, ie from the manufacturer or a test laboratory, or of compliance with an acceptable comparable non-European standard, or by the comparison of the vehicle against the specification of an Approved vehicle, ie using a model report.</p> <ol style="list-style-type: none"> In the case of a "disabled person's vehicle", to which this item applies (see 'Appliance' item c) check that the required number of anchorage points are fitted. <ul style="list-style-type: none"> for the type of belt fitted; and to meet the minimum requirement. <table border="1" data-bbox="943 879 1877 1136" style="margin: 10px auto;"> <thead> <tr> <th colspan="6">Minimum Number of Anchorage Points - 4 or more wheeled vehicles</th> </tr> <tr> <th colspan="3">Front</th> <th colspan="3">Rear</th> </tr> <tr> <th>Driver</th> <th>Centre</th> <th>Passenger</th> <th>Forward Facing Outboard Seats</th> <th>Forward Facing Centre Seats</th> <th>Rear Facing Seats*</th> </tr> </thead> <tbody> <tr> <td style="text-align: center;">3</td> <td style="text-align: center;">2 (see Note 1)</td> <td style="text-align: center;">3</td> <td style="text-align: center;">3</td> <td style="text-align: center;">2</td> <td style="text-align: center;">2</td> </tr> </tbody> </table> <p style="text-align: center;">*Vehicle date of manufacture from 1-10-99 only</p> <p>NOTE 1: The front centre seat will require 3 anchorages where the windscreen is located</p> <ul style="list-style-type: none"> in the case of a fixed (non-sliding) seat, within 840mm. of the seat reference point in the case of a sliding seat, within 840mm. of the seat reference point when the seat is 127mm forward of its rearmost position. (For seat reference point, see standard SVA Section 5, Annex 4) <p style="text-align: right;">Cont'd ▼</p>	Minimum Number of Anchorage Points - 4 or more wheeled vehicles						Front			Rear			Driver	Centre	Passenger	Forward Facing Outboard Seats	Forward Facing Centre Seats	Rear Facing Seats*	3	2 (see Note 1)	3	3	2	2	<ol style="list-style-type: none"> The vehicle is not accompanied by satisfactory evidence of compliance with the required standard for "Seat Belt Anchorages". An anchorage point missing. <p style="text-align: right;">Cont'd ▼</p>
Minimum Number of Anchorage Points - 4 or more wheeled vehicles																										
Front			Rear																							
Driver	Centre	Passenger	Forward Facing Outboard Seats	Forward Facing Centre Seats	Rear Facing Seats*																					
3	2 (see Note 1)	3	3	2	2																					

E5a Seat Belt Anchorages (cont'd)

Application	Procedure and Standards	Reasons for Failure
<ul style="list-style-type: none"> ▪ a rebuilt vehicle ▪ a motor ambulance ▪ a motor caravan ▪ a hearse, and ▪ an armoured vehicle. <p>NOTE: For definitions see "Foreword" item 9.</p>	<p>3. In the case of a disabled person's vehicle to which this item applies (see 'Application' item c) check each anchorage and the surrounding vehicle structure and assess the load bearing capabilities. The anchorage and surrounding structure must be of adequate strength to withstand the load likely to be imposed by the torso in the event of a vehicle frontal impact. On seats to which seat belts are directly mounted (integral seat belts) consideration must be given to the seat mounting as a belt anchorage point (see standard SVA Section 5, Annex 1).</p> <p>NOTE 1: Seat belt anchorage points must comply with the strength and location requirements of Directive 76/115 EEC, or to an equivalent safety standard.</p> <p>NOTE 2: Materials and construction methods must be taken into account.</p> <p>NOTE 3: Comparable methods to that of a known approved vehicle type may be acceptable. Evidence that the vehicle is of identical structure to a vehicle which has been demonstrated to comply with the requirements may be taken to confirm compliance.</p> <p>NOTE 4: Vehicles (typically "people carriers" of 5 - 8 seats) may be fitted with seats that were not produced by the vehicle manufacturer but were produced by or for the vehicle converter, being of the type used in larger PSVs e.g. having a frame of tubular design, (generally having separate bolt-on legs) and onto which the seat belts are mounted.</p> <p>Where a vehicle is presented with this type of seat, the presenter will be required to provide evidence that the seats of this type fitted to the vehicle meet the requirements for an M1 category vehicle. This should be in the form of a declaration from the vehicle converter or seat manufacturer making</p> <p style="text-align: right;">Cont'd ▼</p>	<p>3. A seat belt anchorage or the surrounding vehicle structure is of inadequate strength and likely to fail.</p>

Seat Belt Anchorages (cont'd) **E5a**

Application	Procedure and Standards	Reasons for Failure
	<p>reference to the vehicle concerned, confirming that the seats fitted (other than the original vehicle manufacturer's seats) meet the strength and positional requirements of Directive 76/115/EEC for a category M1 vehicle, and supported by documentary evidence of the seat test results.</p> <p>Where the evidence provided relates to the seat only, consideration must be given to the seat mounting as a belt anchorage point.</p>	

DRAFT

Seat Belt Installation E5b

Application	Procedure and Standards	Reasons for Failure
<p>All vehicles except</p> <ol style="list-style-type: none"> Goods vehicles. Three wheeled vehicles. Passenger vehicles having a date of manufacture before 1 July 1997. Disabled Person's vehicles, <ol style="list-style-type: none"> in a seating position where an anchorage point has been fitted after the manufacture of the original vehicle (Standard SVA applies in this position) in a seating position fitted with a disabled person's belt (Standard SVA applies in this position). <p>NOTE: The vehicle must comply with the requirements of this section in all other seating positions.</p> <ol style="list-style-type: none"> those not subject to ESVA ie <ul style="list-style-type: none"> ▪ a left hand drive vehicle ▪ a personal import ▪ an amateur built vehicle ▪ a vehicle manufactured in very low volume ▪ a vehicle manufactured using parts of a registered vehicle ▪ a rebuilt vehicle ▪ a motor ambulance <p style="text-align: right;">Cont'd ▼</p>	<ol style="list-style-type: none"> Check that the vehicle is accompanied by satisfactory documentary evidence of compliance with the requirements of item E5b listed in the "Enhanced SVA Requirements" Annex. <p>NOTE: Where documentary evidence of compliance with item E5b is provided (and the vehicle has not been modified) the vehicle is considered to have met the requirements of this section.</p> <p>Where evidence is not provided the following criteria must be met.</p> Check each seat requiring a seat belt is fitted with a belt of the appropriate type (see Annex 1 and 2). Check each seat belt including any optional belt is secured <ul style="list-style-type: none"> ▪ to the vehicle structure or where the belt is integral with the seat to the seat structure ▪ using a fixing of adequate strength ▪ such that it can be separated from the anchorage without causing damage to the anchorage. <p>NOTE 1: A suitable single bolt fixing of adequate strength would be, for example, a bolt of at least 11mm (7/16") diameter of grade 8.8 (the grade may not be shown on a bolt produced for a seat belt anchorage).</p> <p>Other bolt fixings may be acceptable providing they are of equivalent strength.</p> <p>Two adjacent seat belts may be secured by one bolt. In this case consideration must be given to the additional loads on the anchorage.</p> <p style="text-align: right;">Cont'd ▼</p>	<ol style="list-style-type: none"> The vehicle is not accompanied by satisfactory evidence of compliance with the required standard for "Seat Belt Installation" and does not have equivalent characteristics to an approved vehicle of the same category. A seat belt missing or of the wrong type. A seat belt <ul style="list-style-type: none"> ▪ not securely fixed to the vehicle structure or, where the belt is integral with the seat, to the seat structure ▪ fixing of inadequate strength ▪ cannot be separated from the anchorage without causing damage to the anchorage. <p style="text-align: right;">Cont'd ▼</p>

E5b Seat Belt Installation (cont'd)

Application	Procedure and Standards	Reasons for Failure
<ul style="list-style-type: none"> ▪ a motor caravan ▪ a hearse, and ▪ an armoured vehicle. <p>NOTE: For definitions see "Foreword" item 9.</p> <p>f. in seating positions where there are folding (tip-up) seats intended for occasional use and normally folded out of the way, side facing seats or in respect of a vehicle having a date of manufacture before 1 October 1999 rear facing seats.</p> <p>NOTE: Care must be taken in assessing whether seats are by manufacture intended for everyday use with the ability to be folded for additional luggage space or intended for occasional use. Seats for everyday use are not considered to be occasional seats.</p> <p>g. passenger vehicles having a date of manufacture before 1 October 1999 in respect of items 8a and 8b only.</p>	<p>NOTE 2: In order that a seat belt can be separated from the anchorage without causing damage to the anchorage, for example a mounting in the side of a tube or box section, it is a requirement that the bolt is secured into a "fixed" threaded hole or captive nut. (The presenter may be required to demonstrate this condition is met). The bolt may be secured into an alternative fixing, eg a lock nut of suitable strength, where access is provided to the "rear" of the mounting to enable separation/re-attachment of the belt.</p> <p>4. Check all seat belts (mandatory and optional) fitted,</p> <ul style="list-style-type: none"> a. bear a designated approval mark ("E" or "e"), or b. have equivalent characteristics to that of a belt approved for the same category of vehicle. <p>Check the characteristics include</p> <ul style="list-style-type: none"> i. the webbing is of an equivalent type of material and where it is likely to come into contact with the body of the wearer is at least 46mm (33mm in the case of a harness belt shoulder straps) in width. ii. all components are suitably protected against corrosion, eg plated or coated. iii. the locking mechanism, ie the buckle, when both under load and not under load, can be released by a single movement in one direction by either hand. iv. other than a harness belt the locking mechanism contact area with the body of the wearer is not less than 46mm in width. 	<p>4.</p> <ul style="list-style-type: none"> a. A seat belt <ul style="list-style-type: none"> ▪ not permanently marked with an acceptable approval marking, and ▪ does not have the equivalent characteristics to that of a belt approved for the same category of vehicle.

Cont'd ▼

Cont'd ▼

Seat Belt Installation (cont'd) **E5b**

Application	Procedure and Standards	Reasons for Failure
	<p>v. for a static seat belt there is a manual adjusting device</p> <ul style="list-style-type: none"> ▪ accessible to the wearer when seated ▪ convenient and easy to use ▪ capable of being tightened with one hand. <p>vi. for a retracting belt</p> <ul style="list-style-type: none"> ▪ the retractor locks when the vehicle is subject to deceleration, tilt or the belt is pulled quickly from the retracting mechanism. <p>5. Fasten each belt locking mechanism (buckle) and try to pull the locked section apart. On retracting seat belts, check that, with the mechanism fastened and the seat unoccupied, excess webbing is wound into the retractor unit.</p> <p>NOTE: Some types of retracting belt might need help before they retract.</p> <p>Operate the release mechanism while pulling on the belt to check that it releases when required.</p> <p>6. Where a lap/diagonal retracting belt is fitted, check the position and operation of the retractor mechanism.</p> <p>NOTE 1: A belt may be fitted with retractor mechanisms on both lap and diagonal sections. If fitted with a single retractor mechanism it must act initially on the diagonal (shoulder) section.</p> <p>NOTE 2: An “automatically locking” retractor (ie one that allows extension of the belt to the desired length and when the buckle is fastened locks on retraction but then prevents subsequent</p>	<p>5.</p> <ul style="list-style-type: none"> a. A seat belt locking mechanism (buckle) does not secure or release the belt as intended. b. A retractor mechanism does not retract the webbing sufficiently to remove all the slack from the belt with the locking mechanism fastened and the seat unoccupied. <p>NOTE: In doubtful cases, this should be checked with the seat set in its rearmost position.</p> <p>6. A retractor mechanism</p> <ul style="list-style-type: none"> ▪ acts initially on the lap section of the seat belt ▪ of the “automatically locking” type (other than in the case of a child restraint - see Note 2 in Procedure and Standards).

Cont'd ▼

Cont'd ▼

E5b Seat Belt Installation (cont'd)

Application	Procedure and Standards	Reasons for Failure
	<p>forward movement by the wearer, unlike a typical inertia reel belt), is not permitted unless the feature is only provided after full extension of the belt from the retractor, ie for use as a child restraint.</p> <p>7. Check each lap belt or three-point belt has provision for the safe and convenient storage of the belt when not in use.</p> <p>NOTE: An independent belt storage facility is only necessary where it is needed to ensure the belt is always accessible for use.</p> <p>8.</p> <p>a. Check every passenger seating position which is fitted with an air bag is provided with a label warning against the use of a rearward facing child restraint on the seat. (Applies to vehicles having a date of manufacture from 1 Oct. 1999 only).</p> <p>NOTE 1: This item shall not apply where a mechanism is fitted which senses automatically the presence of a rearward facing child restraint and prevents air bag deployment.</p> <p>NOTE 2: Where a seat is capable of being turned for use when the vehicle is stationary, this requirement only applies when the seat is in the position designated for normal use when travelling on a road.</p>	<p>7. A seat belt has no provision for its safe and convenient storage.</p> <p>8.</p> <p>a. An air bag/child restraint warning label missing.</p>

Cont'd ▼

Cont'd ▼

Seat Belt Installation (cont'd) **E5b**

Application	Procedure and Standards	Reasons for Failure
	<p>b. Check</p> <p>i) the label is</p> <ul style="list-style-type: none"> ▪ permanently fixed to the vehicle ▪ in pictogram form (although explanatory text may be included) (see diagram below) ▪ easily visible in front of a person about to install a rearward facing child restraint <p>ii) if the label is not visible when the door is closed that a permanent reference is visible at all times.</p>	<p>b. An air bag/child restraint warning label</p> <p>i)</p> <ul style="list-style-type: none"> ▪ not permanently fixed to the vehicle ▪ not in pictogram form ▪ not easily visible <p>ii) not visible with the door closed and no permanent reference is visible.</p>



Annex 1

Seat Belt Installation Requirements

E5b

Vehicle Description and Effective Date (see note 1)	Seat Positions				
	"Outboard" Driver's and Forward Facing Front Passenger's Seats (see note 4)	Centre Front Seats (see note 10)	"Outboard" Forward Facing Rear Seats (see note 4)	Centre Forward Facing Rear Seats	Rear Facing Seats
Passenger vehicles and Dual Purpose vehicles with not more than 8 passenger seats; from 1 July 1997 to 30 September 1999	3 point retractor belt (see notes 2 & 3)	Lap belt or 3 point belt (see notes 2, 3 & 8) (retractor optional)	3 point belt (see notes 2, 3 & 9) (retractor optional)	Lap belt or 3 point belt (see notes 2 & 3) (retractor optional)	No Requirement
Motor Ambulances, Motor Caravans and Hearses (irrespective of design weights) from 1 July 1997 to 30 September 1999	3 point retractor belt (see notes 2 & 3)	Lap belt or 3 point belt (see notes 2, 3 & 8) (retractor optional)	Lap belt or 3 point belt (see notes 2, 3 & 7) (retractor optional)	Lap belt or 3 point belt (see notes 2, 3 & 7) (retractor optional)	No Requirement
Passenger vehicles and Dual Purpose vehicles with not more than 8 passenger seats; from 1 October 1999	3 point retractor belt (see notes 2 & 3)	Lap belt or 3 point belt (see notes 2, 3 & 8) (retractor optional)	3 point retractor belt (see notes 2, 3 & 9)	Lap belt or 3 point belt (see notes 2 & 3) (retractor optional)	Lap belt or 3 point belt (see notes 2 & 3) (retractor optional)
Motor Ambulances, Motor Caravans and Hearses (irrespective of design weights) from 1 October 1999	3 point retractor belt (see notes 2 & 3)	Lap belt or 3 point belt (see notes 2, 3 & 8) (retractor optional)	Lap belt or 3 point belt (see notes 2, 3 & 7) (retractor optional)	Lap belt or 3 point belt (see notes 2, 3 & 7) (retractor optional)	Lap belt or 3 point belt (retractor optional) (see notes 2, 3 & 7)

NOTE 1: The “Effective Date” shall be the date of manufacture of the vehicle other than in the case of a Motor Caravan, Motor Ambulance or Hearse it shall be the date of manufacture of the base vehicle prior to conversion.

NOTE 2: “3 point belt” means a belt which,

- i. restrains the upper and lower parts of the torso
- ii. includes a lap belt
- iii. is anchored at not less than three points, and
- iv. is designed for use by an adult.

NOTE 3: An adult harness belt comprising a lap belt and shoulder straps is an acceptable alternative to any of the seat belts listed.

NOTE 4: Outboard seats are seats closest to the vehicle sides.

NOTE 5: Side facing seats are not required to be fitted with seat belts.

NOTE 6: Occasional seats that fold when not in use are not required to be fitted with seat belts. A front centre seat on which the backrest folds down to become a driver/passenger armrest is not considered to be an occasional seat and should meet the required criteria.

NOTE 7: In respect of Motor Caravans, Motor Ambulances and Hearses; only seats in the area to the rear of the driver’s seated position intended for use when the vehicle is travelling on a road are required to be fitted with seat belts.

NOTE 8: A three point belt is required where, due to the seat position the windscreen is located

- in the case of a fixed (non-sliding) seat, within 840mm of the seat reference point,
- in the case of a sliding seat, within 840mm of the seat reference point when the seat is 127mm forward of its rearmost position.

NOTE 9: A lap belt is acceptable where there is a passage between the seat and the nearest side wall of the vehicle, intended to permit access by passengers, where the distance between the side wall and the vertical centre line of the seat measured at the seat reference point, is more than 500mm.

NOTE 10: A seat in a single seat vehicle or a seat being the only seat along that particular transverse plane is considered to be an “outboard” seat.

Protective Steering E14a

Application	Procedure and Standards	Reasons for Failure
<p>All vehicles except</p> <ol style="list-style-type: none"> a. Goods vehicles. b. Three wheeled vehicles. c. those adapted to a category M1 (a passenger vehicle) that were previously a goods vehicle having a design weight of 1500kg or more or any passenger vehicle having more than 8 passenger seats (ie M2 or M3) (See Procedure and Standards Note 2). d. Disabled Person's vehicles, where the vehicle is not required to comply in respect of an adaptation. Evidence of compliance of the unadapted vehicle is required if that vehicle was of a category subject to the requirements of the Directive (eg a goods vehicle having a design weight of less than 1500kg or an M1 category). e. those not subject to ESVA ie <ul style="list-style-type: none"> ▪ a left hand drive vehicle ▪ a personal import ▪ an amateur built vehicle ▪ a vehicle manufactured in very low volume ▪ a vehicle manufactured using parts of a registered vehicle ▪ a rebuilt vehicle <p style="text-align: right;">Cont'd ▼</p>	<ol style="list-style-type: none"> 1. Check that the vehicle is accompanied by satisfactory documentary evidence of compliance with the requirements of item E14a listed in the "Enhanced SVA Requirements" Annex. <p>NOTE 1: Evidence of compliance may be in the form of vehicle specific documentary evidence, ie from the manufacturer or a test laboratory, or of compliance with an acceptable comparable non-European standard, or by the comparison of the vehicle against the specification of an Approved vehicle, ie using a model report.</p> <p>NOTE 2: If the vehicle has been adapted from an N1 goods vehicle having a design weight of less than 1500kg and the adaptation does not directly affect the "Protective Steering", satisfactory evidence of compliance to the N1 (goods vehicle) category will be acceptable.</p>	<ol style="list-style-type: none"> 1. The vehicle is not accompanied by satisfactory evidence of compliance with the required standard for "Protective Steering".

E14a Protective Steering (cont'd)

Application	Procedure and Standards	Reasons for Failure
<ul style="list-style-type: none">▪ a motor ambulance▪ a motor caravan▪ a hearse, and▪ an armoured vehicle. <p>NOTE: For definitions see "Foreword" item 9.</p>		

DRAFT

Frontal Impact E14b

Application	Procedure and Standards	Reasons for Failure
<p>All vehicles except</p> <ul style="list-style-type: none"> a. Goods vehicles. b. Three wheeled vehicles. c. those having a date of manufacture before 1 October 2003. d. those adapted to category M1 (a passenger vehicle) that were previously a passenger vehicle having more than 8 passenger seats (ie M2 or M3) or a goods vehicle. e. those having a manufacturer's design weight exceeding 2500kg. f. Disabled Person's vehicles, where the vehicle is not required to comply in respect of the adaptation. Evidence of compliance of the unadapted vehicle is required. g. those not subject to ESVA ie <ul style="list-style-type: none"> ▪ a left hand drive vehicle ▪ a personal import ▪ an amateur built vehicle ▪ a vehicle manufactured in very low volume ▪ a vehicle manufactured using parts of a registered vehicle ▪ a rebuilt vehicle ▪ a motor ambulance ▪ a motor caravan ▪ a hearse, and ▪ an armoured vehicle. <p>NOTE: For definitions see "Foreword" item 9.</p>	<p>1. Check that the vehicle is accompanied by satisfactory documentary evidence of compliance with the requirements of item E14b listed in the "Enhanced SVA Requirements" Annex.</p> <p>NOTE: Evidence of compliance may be in the form of vehicle specific documentary evidence, ie from the manufacturer or a test laboratory, or of compliance with an acceptable comparable non-European standard, or by the comparison of the vehicle against the specification of an Approved vehicle, ie using a model report.</p>	<p>1. The vehicle is not accompanied by satisfactory evidence of compliance with the required standard for "Frontal Impact".</p>

Side Impact E14c

Application	Procedure and Standards	Reasons for Failure
<p>All vehicles except</p> <ol style="list-style-type: none"> Goods vehicles. Three wheeled vehicles. those having a date of manufacture before 1 October 2003. those where the manufacturer's seat reference point of the lowest front seat is more than 700mm from the ground. <p>Note: Seat reference point is determined</p> <ul style="list-style-type: none"> ▪ with the seat/seat mounting as fitted at the time of manufacture, and ▪ with a seat that is adjustable in height in its "mid position", and ▪ as given in Standard SVA Section 5, Annex 4 (Evidence from the vehicle manufacturer or a test laboratory will also be considered). <ol style="list-style-type: none"> those adapted to category M1 (passenger vehicle) that were previously a goods vehicle of category N1 (design weight not exceeding 3.5 tonnes) having a seat reference point more than 700mm from the ground, any goods vehicle having a design weight exceeding 3.5 tonnes (ie N2 or N3) or a passenger vehicle <p style="text-align: right;">Cont'd ▼</p>	<ol style="list-style-type: none"> Check that the vehicle is accompanied by satisfactory documentary evidence of compliance with the requirements of item E14c listed in the "Enhanced SVA Requirements" Annex. <p>NOTE 1: Evidence of compliance may be in the form of vehicle specific documentary evidence, ie from the manufacturer or a test laboratory, or of compliance with an acceptable comparable non-European standard, or by the comparison of the vehicle against the specification of an Approved vehicle, ie using a model report.</p> <p>NOTE 2: If the vehicle has been adapted from an N1 goods vehicle having a seat reference point not more than 700mm from the ground and the adaptation does not directly affect the "Side Impact" satisfactory evidence of compliance to the N1 (goods vehicle) category will be acceptable.</p>	<ol style="list-style-type: none"> The vehicle is not accompanied by satisfactory evidence of compliance with the required standard for "Side Impact".

E14c Side Impact (cont'd)

Application	Procedure and Standards	Reasons for Failure
<p>having more than 8 passenger seats (ie M2 or M3) (See Procedure and Standards Note 2).</p> <p>f. Disabled Person's vehicles, where the vehicle is not required to comply in respect of the adaptation. (Evidence of compliance in the areas not subject to or affected by the adaptation is required).</p> <p>g. those not subject to ESVA ie</p> <ul style="list-style-type: none">▪ a left hand drive vehicle▪ a personal import▪ an amateur built vehicle▪ a vehicle manufactured in very low volume▪ a vehicle manufactured using parts of a registered vehicle▪ a rebuilt vehicle▪ a motor ambulance▪ a motor caravan▪ a hearse, and▪ an armoured vehicle. <p>NOTE: For definitions see "Foreword" item 9.</p>		

Brakes E16*

Application	Procedure and Standards	Reasons for Failure
<p>All vehicles except</p> <ol style="list-style-type: none"> a. Three wheeled vehicles. b. those having a date of manufacture before 1 April 1995. c. those not subject to ESVA ie <ul style="list-style-type: none"> ▪ a left hand drive vehicle ▪ a personal import ▪ an amateur built vehicle ▪ a vehicle manufactured in very low volume ▪ a vehicle manufactured using parts of a registered vehicle ▪ a rebuilt vehicle ▪ a motor ambulance ▪ a motor caravan ▪ a hearse, and ▪ an armoured vehicle. d. Disabled Person's vehicles, in respect of an adaptation to the braking system (Evidence of compliance in the areas not subject to or affected by, the modification is required). <p>NOTE: For definitions see "Foreword" item 9.</p> <p style="text-align: right;">Cont'd ▼</p>	<ol style="list-style-type: none"> 1. Check that the vehicle is accompanied by satisfactory documentary evidence of compliance with the requirements of item E16 listed in the "Enhanced SVA Requirements" Annex. <p>NOTE 1: Evidence of compliance may be in the form of vehicle specific documentary evidence, ie from the manufacturer or a test laboratory, or of compliance with an acceptable comparable non-European standard, or by the comparison of the vehicle against the specification of an Approved vehicle, ie using a model report.</p> <p>NOTE 2: If the vehicle has been adapted to an M1 category from a goods vehicle ('N' category) or a passenger vehicle having more than 8 passenger seats (ie M2 or M3) or adapted to an N1 goods vehicle from another category, and the adaptation does not affect the braking system, satisfactory evidence of compliance to the original vehicle category will be acceptable.</p> <p>Where the only evidence of compliance provided is evidence of Japanese type designation, the requirements in item 2 (or if appropriate item 3) below must also be checked (unless the vehicle is exempt as in Application item e).</p> 2. Roller Brake Test A vehicle that incorporates an adjustment device (eg pedal linkage balance bar) that adjusts the front/rear braking ratio (longitudinal brake distribution) must be tested in the "worst case" condition, ie maximum rear axle braking. <p>NOTE: Devices that allow further adjustment, eg lock nuts/adjustable stops/split pins, will not, in isolation be considered as capable of preventing further adjustment to a "worse" condition. (A roll pin will be considered acceptable)</p> <p style="text-align: right;">Cont'd ▼</p>	<ol style="list-style-type: none"> 1. The vehicle is not accompanied by satisfactory evidence of compliance with the required standard for "Brakes". 2. The braking ratio of the axles is not, for all values of total brake force less than the friction force ratio (taking account of weight transfer) between axles with the vehicle in running order. <p>In cases where the brakes are tested in a "cold" condition and this requirement is not met, the presenter should be given the opportunity to drive the vehicle (slowly) to heat up the brakes (not more than normal operating temperature) and the vehicle re-checked.</p>

E16* Brakes

Application	Procedure and Standards	Reasons for Failure
<p>e. in respect of item 2 and 3 only, vehicles on which</p> <ul style="list-style-type: none"> ▪ the brakes on the rear wheels are fitted with an anti-lock device which was fitted at the time of manufacture, and ▪ it appears that the anti-lock device complies with the definition in Directive 71/320/EEC, eg it comprises sensors, control valves and/or modulators to modulate the braking force of any wheel(s) that are about to “lock”. 	<p>The vehicle presenter may be required to adjust any such device in order to comply with this condition prior to the brake performance test.</p> <p>Certain vehicles should not be tested on a roller brake tester, eg vehicles</p> <ul style="list-style-type: none"> ▪ of the 4x4 SWB off road type ▪ with more than one driving axle permanently engaged ▪ with belt-driven transmission ▪ having brakes for which the servo operates only when the vehicle is moving. <p>These vehicles should be tested using a dynamic test.</p> <p>Vehicles fitted with a limited-slip differential must be tested on the roller brake tester. If due to vehicle design, it is found that the roller brake tester cannot be used, the vehicle must be subject to a dynamic test.</p> <p>Vehicles with damaged, under inflated or studded tyres may not be considered to be in a suitable condition to carry out a brake performance test.</p> <p>Vehicles with automatic transmission must never be roller brake tested with the gear selector in the “P” park position.</p> <p>Fit a brake pedal effort measuring device before conducting the test.</p> <p>NOTE: In some cases, it may be necessary to chock the wheels not under test.</p> <p>When testing “light weight” vehicles both rear wheels must be chocked. This helps to prevent the front of the vehicle “lifting” in the rollers and improves the efficiency reading obtained before wheel lock.</p> <p style="text-align: right;">Cont'd ▼</p>	

Brakes E16*

Application	Procedure and Standards	Reasons for Failure
	<p>a. Position the front wheels of the vehicle in the rollers of the brake tester and then run both sets of rollers together to align the vehicle. With one set of rollers revolving at a time, gradually depress the service brake until maximum effort is achieved, or until the wheel locks.</p> <p>Record the reading at which the maximum braking effort is achieved for each wheel and whether "lock-up" occurs. Release the service brake.</p> <p>With the engine 'off', deplete all the vacuum from the servo reservoir (if fitted).</p> <p>NOTE: In the case of a power hydraulic system, the pressure should not be depleted.</p> <p>Start both sets of rollers and observing the load cell, progressively apply the service brake in increments, for example, of 10kg. Aim to stop just short of the value at which wheel-slip occurs.</p> <p>Record the brake effort obtained at each wheel for every increment of effort applied to the brake pedal. Stop the rollers.</p> <p>b. Release the brakes and drive the vehicle forward until the rear wheels are in the rollers.</p> <p>Repeat operation "a" for each rear axle recording the brake efforts obtained during each operation.</p> <p>With reference to the annex to this section and using the brake figures recorded, calculate the value of the braking/friction force ratios and assess the result obtained.</p> <p style="text-align: right;">Cont'd ▼</p>	

E16* Brakes

Application	Procedure and Standards	Reasons for Failure
	<p>3 Dynamic Test This method of test must only be used where the vehicle, due to a design characteristic cannot be tested on a Roller Brake Tester.</p> <p>A vehicle that incorporates an adjustment device that adjusts the front/rear braking ratio (longitudinal brake distribution) must be tested in the maximum rear axle braking position.</p> <p>The vehicle presenter may be required to adjust any such device in order to comply with this condition prior to the brake performance test.</p> <p>a. Drive the vehicle on a level road at a steady speed of approximately 20mph (32 km/h) and apply the service brake sufficient only to obtain wheel lock. Observe whether all the wheels of the rear axle(s) "lock" prior to both wheels of the front axle indicating an incorrect front/rear brake distribution. It may be necessary to repeat this operation to determine the order of wheel lock.</p> <p>Note: The presenter or another person may be required to drive the vehicle under the direction of the examiner. The examiner must then become the observer.</p>	<p>3. All wheels of the rear axle(s) "lock" prior to both wheels of the front axle.</p>

Noise E17*

Application	Procedure and Standards	Reasons for Failure
<p>All vehicles except</p> <p>a. those not subject to ESVA ie</p> <ul style="list-style-type: none"> ▪ a left hand drive vehicle ▪ a personal import ▪ an amateur built vehicle ▪ a vehicle manufactured in very low volume ▪ a vehicle manufactured using parts of a registered vehicle ▪ a rebuilt vehicle ▪ a motor ambulance ▪ a motor caravan ▪ a hearse, and ▪ an armoured vehicle. <p>NOTE: For definitions see "Foreword" item 9.</p>	<p>1. Check that the vehicle is accompanied by satisfactory evidence of compliance with the requirements of item E17 listed in the "Enhanced SVA Requirements" Annex.</p> <p>NOTE 1: Evidence of compliance may be in the form of documentary evidence, ie from the manufacturer or a test laboratory, or of compliance with an acceptable comparable non-European standard, or by the comparison of the vehicle against the specification of a vehicle that is known to meet the requirements (using a model report).</p> <p>NOTE 2: If the vehicle has been adapted to an M1 category from a goods vehicle ('N' category) or a passenger vehicle having more than 8 passenger seats (ie M2 or M3) or adapted to an N1 goods vehicle from another category, and the adaptation does not directly affect the noise emitted, satisfactory evidence of compliance to the vehicles original category will be acceptable.</p> <p>NOTE 3: Where evidence of compliance has been provided, subsequent modification to the exhaust system will be permitted providing</p> <ul style="list-style-type: none"> ▪ it is downstream of any emissions control device (eg catalyst) and ▪ the emission control device and silencer are identical to that fitted at the time compliance was demonstrated. <p>Note 4: The following check must be carried out where evidence of compliance has been submitted using a model report.</p> <p>Position the vehicle on an unobstructed test site (concrete or asphalt) which covers a rectangular area the sides of which are at least 3 metres from the vehicle sides, front and rear.</p> <p style="text-align: right;">Cont'd ▼</p>	<p>1. The vehicle is not accompanied by satisfactory evidence of compliance with the required standard for "Noise".</p>

E17* Noise (cont'd)

Application	Procedure and Standards	Reasons for Failure
	<p>Ensure the engine is at normal operating temperature.</p> <p>Using a sound level meter of 'Type 1' (as defined in BSEN 5969 or IEC651) to the manufacturer's instructions, carry out a static noise check.</p> <p>Place the microphone</p> <ul style="list-style-type: none"> ▪ at the height of the exhaust outlet, or a height of 200mm, whichever is the higher ▪ at an angle of 45° to the exhaust outlet in the direction which gives the greatest possible distance between it and the vehicle contour ▪ at a distance of 500mm from the exhaust outlet. <p>NOTE: If the exhaust has several outlets which are not more than 300mm apart and which are connected to the same silencer, the microphone must face the outlet closest to the vehicle contour or the highest above the ground. In all other cases, separate measurements must be taken, the highest recorded being the test value.</p> <p>Run the engine at a constant speed of 3/4 of its maximum power speed.</p> <p>The maximum power engine speed will be stated on page 1 of the model report.</p> <p>Check the level of sound emitted is not more than 2 dbA above that recorded on page 1 of the model report.</p>	

CO2 / fuel consumption **E18b**

Application	Procedure and Standards	Reasons for Failure
<p>All vehicles except</p> <ul style="list-style-type: none"> a. Three wheeled vehicles. b. Goods vehicles c. those having a date of manufacture before 1 January 97 d. those adapted to category M1 (a passenger vehicle) that were previously a passenger vehicle having more than 8 passenger seats (ie M2 or M3) or a goods vehicle. e. those not subject to ESVA ie <ul style="list-style-type: none"> ▪ a left hand drive vehicle ▪ a personal import ▪ an amateur built vehicle ▪ a vehicle manufactured in very low volume ▪ a vehicle manufactured using parts of a registered vehicle ▪ a rebuilt vehicle ▪ a motor ambulance ▪ a motor caravan ▪ a hearse, and ▪ an armoured vehicle. <p>NOTE: For definitions see "Foreword" item 9.</p>	<p>1. Check that the vehicle is accompanied by satisfactory evidence of compliance with the requirements of item E18b listed in the "Enhanced SVA Requirements" Annex.</p> <p>NOTE 1: Evidence of compliance may be in the form of vehicle specific documentary evidence, ie from the manufacturer or a test laboratory, or of compliance with an acceptable comparable non-European standard, or by the comparison of the vehicle against the specification of an Approved vehicle, ie using a model report.</p> <p>NOTE 2: Where evidence of compliance has been provided, subsequent modification to the exhaust system will be permitted providing</p> <ul style="list-style-type: none"> ▪ it is downstream of any emissions control device (eg catalyst) and ▪ the emissions control device is identical to that fitted before the modification. 	<p>1. The vehicle is not accompanied by satisfactory evidence of compliance with the required standard for "CO2/fuel consumption".</p>

Annex 1

Enhanced SVA Requirements including Comparable* Non-European Standards

* Evidence that a vehicle complies with one of the comparable non-European standards will be accepted instead of compliance with the European standard for each subject matter and date of vehicle manufacture. This does not necessarily mean that these standards are truly equivalent but the Department has judged them to be sufficiently comparable in terms of their practical effect on vehicle safety, security or environmental protection to accept them as alternatives for the purpose of SVA.

SUBJECT	DATE OF MANUFACTURE	EUROPEAN STANDARD (EC or ECE EQUIVALENT)	COMPARABLE NON-EUROPEAN STANDARDS					NOTES
			UNITED STATES	CANADA	JAPAN	AUSTRALIA	OTHER	
E1 Anti-theft devices	1/10/98	Directive 74/61 EEC as last amended by 95/56/EC annex 5&6 or ECE R. 18.02 para. 7 and ECE R.97.01 Supp.1. para. 5,6 and 7 and para. 31,32 and 33.	—	—	—	—	Immobiliser requirements as in Annex 2a; If fitted, alarm system requirements as in Annex 2b.	Not applicable to a) Goods vehicles, b) Three wheeled vehicles. Fitment of immobiliser is mandatory for passenger vehicles. Where an "after-market" immobiliser or alarm is fitted, evidence of compliance from an authorised test laboratory or an original certificate of installation from a Vehicle Systems Installation Board (VSIB) accredited installer is considered necessary to confirm compliance.

Enhanced SVA Requirements including Comparable* Non-European Standards

Annex 1

SUBJECT	DATE OF MANUFACTURE	EUROPEAN STANDARD (EC or ECE EQUIVALENT)	COMPARABLE NON-EUROPEAN STANDARDS					NOTES
			UNITED STATES	CANADA	JAPAN	AUSTRALIA	OTHER	
E5a Seat belt anchorages	1/7/91	Directive 76/115 EEC as last amended by 82/318/EEC annex 1, para. 4 and 5 or ECE R. 14.02 para. 5,6 and 7.	FMVSS 210 including associated requirements of FMVSS 207 and FMVSS 208	CMVSS 210 including associated requirements of CMVSS 207 and CMVSS 208	Jisha 899 - 1983, attachment 17 (TRIAS 37-1987)	ADR 5/04	Korea MVSS Article 103 (Note 1) or Singapore (Note 2) or Hong Kong (Note 3) or BS AU48a or BS AU 140a	Not applicable to a) Goods vehicles, b) Three wheeled vehicles. c) Disabled Persons vehicles in a seating position fitted with an anchorage after the time of original manufacture. (Section E5a item 2 & 3 apply)
	1/7/97	Directive 90/629/EEC annex 1, para. 4 and 5. or ECE R. 14.03 para. 5,6 and 7.	FMVSS 210 and FMVSS 208	CMVSS 210 and CMVSS 208	Jisha 899 -1983 attachment 17 (TRIAS 37-1987) and attachment 11 (TRIAS 47-1993)	ADR 5/04 and ADR 69/00		

Annex 1

Enhanced SVA Requirements including Comparable* Non-European Standards

SUBJECT	DATE OF MANUFACTURE	EUROPEAN STANDARD (EC or ECE EQUIVALENT)	COMPARABLE NON-EUROPEAN STANDARDS					NOTES
			UNITED STATES	CANADA	JAPAN	AUSTRALIA	OTHER	
E5b Installation of seat belts	1/7/97	Directive 77/541/EEC as last amended by Directive 90/628/EEC, annex 1, para. 3.1 to 3.1.9.	—	—	—	—		Not applicable to a) Goods vehicles. b) Three wheeled vehicles. c) Disabled Persons vehicles in a seating position; fitted with an anchorage after the time of original manufacture, or fitted with a Disabled Persons belt. (Standard SVA applies in these positions)
	1/10/99	Directive 96/36/EC annex 1, para. 3.1 to 3.1.10 and 3.1.11 and 3.1.12. or ECE R. 16.04, Supplement 8, para. 8.1 to 8.1.10.3 and 8.1.11 to 8.1.12.	—	—	—	—		

Enhanced SVA Requirements including Comparable* Non-European Standards

Annex 1

SUBJECT	DATE OF MANUFACTURE	EUROPEAN STANDARD (EC or ECE EQUIVALENT)	COMPARABLE NON-EUROPEAN STANDARDS					NOTES
			UNITED STATES	CANADA	JAPAN	AUSTRALIA	OTHER	
E14a Protective steering	1/7/91	Directive 74/297/EEC annex 1, para. 5 and 6. or ECE R. 12.01 or ECE R. 12.02, para. 5 and 6.	FMVSS 203 and FMVSS 204 or FMVSS 208	CMVSS 203 and CMVSS 204 or CMVSS 208	Jisha 899 - 1983 attachment 11 (TRIAS 47-1993) (Note 4)	ADR 10	Korea MVSS article 89 (Note 6) or article 102 (Note 7)	Not applicable to: a) Goods vehicles b) Three wheeled vehicles, c) Motor ambulances, motor caravans and hearses (in each case) having a maximum gross weight of more than 2500kg if the vehicle has been derived from a goods vehicle which either had a maximum gross weight of not less than 1500kg or was manufactured before 1 October 1997. d) Armoured vehicles, e) Forward control vehicles having a date of man. before 1 October 1997.
	1/10/96	Directive 74/297/EEC as last amended by 91/662/EEC annex 1, para. 5 and 6 or ECE R. 12.03 para. 5 and 6.	FMVSS 208	CMVSS 208	"	ADR 69/00 and driver's airbag (Note 5)	Korea MVSS article 102 (Note 7)	

Cont'd ▼

Annex 1

Enhanced SVA Requirements including Comparable* Non-European Standards

SUBJECT	DATE OF MANUFACTURE	EUROPEAN STANDARD (EC or ECE EQUIVALENT)	COMPARABLE NON-EUROPEAN STANDARDS					NOTES
			UNITED STATES	CANADA	JAPAN	AUSTRALIA	OTHER	
E14a Protective steering (cont'd)								<p>f) Disabled Person's vehicles in respect of the adaptation only (Evidence of compliance of the pre-adapted vehicle is required.</p> <p>g) Vehicles adapted to category M1 that were previously a goods vehicle having a design weight of 1500kg or more or any passenger vehicle having more than 8 passenger seats (ie M2 or M3).</p>

Enhanced SVA Requirements including Comparable* Non-European Standards

Annex 1

SUBJECT	DATE OF MANUFACTURE	EUROPEAN STANDARD (EC or ECE EQUIVALENT)	COMPARABLE NON-EUROPEAN STANDARDS					NOTES
			UNITED STATES	CANADA	JAPAN	AUSTRALIA	OTHER	
E14b Frontal impact	1/10/2003	Directive 96/79/EC annex 2, para. 3. or ECE R. 94.01, para. 5.	FMVSS 208 and FMVSS 301	CMVSS 208 and CMVSS 301	Jisha 899 - 1983 attachment 11 (TRIAS 47-1993) (Note 4)	ADR 69/00 (Note 5)	Korea MVSS article 102	Not applicable to a) Goods vehicles. b) Three wheeled vehicles. c) Disabled Persons vehicles in respect of any adaptation only. (Evidence of compliance of the unadapted vehicle is required). d) vehicles adapted to category M1 (a passenger vehicle) that were previously a passenger vehicle having more than 8 passenger seats (ie M2 or M3 or a goods vehicle).

Annex 1

Enhanced SVA Requirements including Comparable* Non-European Standards

SUBJECT	DATE OF MANUFACTURE	EUROPEAN STANDARD (EC or ECE EQUIVALENT)	COMPARABLE NON-EUROPEAN STANDARDS					NOTES
			UNITED STATES	CANADA	JAPAN	AUSTRALIA	OTHER	
E14c Side impact	1/10/2003	Directive 96/27/EC annex 2, para. 3 or ECE R. 95.01, para. 5.	FMVSS 214, paragraph S6 and FMVSS 301	CMVSS 214, paragraph S6 and CMVSS 301	Jisha 899 - 1983 attachment 2 (TRIAS 47-2-1996)	—	—	Not applicable to a) Goods vehicles. b) Three wheeled vehicles. c) Disabled Persons vehicles in respect of any adaptation only. (Evidence of compliance of the unadapted vehicle is required). d) those adapted to category M1 (a passenger vehicle) that were previously a goods vehicle of category N1 having a seat reference point more than 700mm from the ground, any goods vehicle having a design weight exceeding 3500kg (ie N2 or N3) or a passenger vehicle having more than 8 passenger seats (ie M2 or M3).

Enhanced SVA Requirements including Comparable* Non-European Standards

Annex 1

SUBJECT	DATE OF MANUFACTURE	EUROPEAN STANDARD (EC or ECE EQUIVALENT)	COMPARABLE NON-EUROPEAN STANDARDS					NOTES
			UNITED STATES	CANADA	JAPAN	AUSTRALIA	OTHER	
E16 Brakes	1/4/95	Directive 71/320/EEC as last amended by 91/422/EEC annex 1, para. 2. or ECE R. 13.06. para. 5.	FMVSS 105 plus ABS on rear wheels or FMVSS 135	CMVSS 105 plus ABS on rear wheels or CMVSS 135	Jisha 899 - 1983 attachment 5 (TRIAS 11-2-1994)	ADR 31/01 plus ABS on rear wheels (Note 8) ADR 35/01 plus ABS on rear wheels (Note 9)	—	<p>Not applicable to</p> <p>a) Three wheeled vehicles.</p> <p>b) Disabled Persons vehicles in respect of any adaptation only. (Evidence of compliance of the pre-adapted vehicle is required)</p> <p>(Any adaptation or part of a system affected by an adaptation is subject to Standard SVA)</p> <p>———— “ ————</p> <p>NOTE: If a vehicle has been adapted to an M1 or N1 category from another category and the adaptation does not directly affect the braking system, satisfactory evidence of compliance to the original category will be acceptable.</p>
	1/10/99	98/12/EC annex 1, or para. 2.1.1.3. or ECE R. 13.09 para. 5.1.1.3. or ECE R. 13H. para. 5.1.1.3. (Req. for asbestos-free brake linings)	“ plus asbestos-free	“ plus asbestos-free	“ plus asbestos-free	“ plus asbestos-free	— Singapore and Hong Kong prohibit asbestos on vehicles having date of manu. 1.10.99-on.	
	31/3/2001	98/12/EC annex 1, para. 2. or ECE R.13.09 para. 5. or ECE R. 13H. para. 5. (all requirements).	“	“	“	“	—	

Annex 1

Enhanced SVA Requirements including Comparable* Non-European Standards

SUBJECT	DATE OF MANUFACTURE	EUROPEAN STANDARD (EC or ECE EQUIVALENT)	COMPARABLE NON-EUROPEAN STANDARDS					NOTES
			UNITED STATES	CANADA	JAPAN	AUSTRALIA	OTHER	
E17 Noise and silencers	1/7/91	Directive 70/157/EEC as last amended by Directive 84/424/EEC annex 1, para. 5 or ECE R. 51.01, para. 5.	California (SAE J986)	CMVSS 1106	MV Safety Regulations Article 30	ADR 28/01	—	Not applicable to a) Three wheeled vehicles. —— “ ——
	1/1/97	Directive 92/97/EEC or 96/20/EC, annex 1, para. 5 or ECE R. 51.02, para. 5.	—	—	—	—	—	NOTE: If a vehicle has been adapted to an M1 or N1 category from another category and the adaptation does not directly affect the noise emitted, satisfactory evidence of compliance to the original category will be acceptable.

Enhanced SVA Requirements including Comparable* Non-European Standards

Annex 1

SUBJECT	DATE OF MANUFACTURE	EUROPEAN STANDARD (EC or ECE EQUIVALENT)	COMPARABLE NON-EUROPEAN STANDARDS					NOTES
			UNITED STATES	CANADA	JAPAN	AUSTRALIA	OTHER	
E18a Exhaust emissions (Euro-1)	1/1/93	(Note 12 applies to all below) Directive 70/220/EEC as last amended by Directive 91/441/EEC annex 1 para. 5, 7, and 8. or ECE R. 83.01, para. 5, 8 and 13. (passenger cars)	EPA 40 CFR Part 86, or California TLEV, LEV or ULEV	CMVSS 1100	Jisha article 31 (Note 14)	—	—	<p>"Passenger Car" means a motor vehicle which</p> <ul style="list-style-type: none"> ▪ is constructed or adapted to carry passengers and is not a goods vehicle ▪ *has no more than 6 seats including the driver's seat ▪ has a maximum gross weight not exceeding 2500kg. <p>NOTE * does not apply from 1/1/2001 —— " ——</p> <p>NOTE: If a vehicle has been adapted to an M1 or N1 category from another category and the adaptation does not directly affect the emissions, satisfactory evidence of compliance to the original category will be acceptable.</p>
	1/10/94	Directive 93/59/EEC, annex 1 para. 5, 7 and 8 or ECE R. 83.01 para. 5, 8 and 13. (other than passenger cars)	"	"	"	—	—	

Annex 1

Enhanced SVA Requirements including Comparable* Non-European Standards

SUBJECT	DATE OF MANUFACTURE	EUROPEAN STANDARD (EC or ECE EQUIVALENT)	COMPARABLE NON-EUROPEAN STANDARDS					NOTES
			UNITED STATES	CANADA	JAPAN	AUSTRALIA	OTHER	
E18a (cont'd) Exhaust emissions (Euro-2)	1/1/97 (passenger cars-Note 10)	Directive 70/220/EEC as last amended by 94/12/EC annex 1, para. 5. or ECE R. 83.02, para. 5. (applies only to passenger cars)	—	—	—	—	—	"Reference Mass" has the same meaning as in Directive 70/220/EEC as last amended by Directive 96/69. "Class I vehicle" means a goods vehicle (N1) which has a reference mass not exceeding 1305kg "Class II vehicle" means a goods vehicle (N1) which has a reference mass exceeding 1305kg but not exceeding 1760kg "Class III vehicle" means a goods vehicle which has a reference mass exceeding 1760kg
	(See Notes for definitions of all below) 1/10/97 (Class I)	96/69/EC annex 1, para. 5. or ECE R. 83.03, para. 5.	—	—	—	—	—	
	1/10/98 (Category M1 other than passenger cars, Class II & Class III)	"	—	—	—	—	—	
	1/10/99 (LPG & CNG)	98/77/EC annex 1, para. 5, or ECE R. 83.04, para. 5.	—	—	—	—	—	

Enhanced SVA Requirements including Comparable* Non-European Standards

Annex 1

SUBJECT	DATE OF MANUFACTURE	EUROPEAN STANDARD (EC or ECE EQUIVALENT)	COMPARABLE NON-EUROPEAN STANDARDS					NOTES
			UNITED STATES	CANADA	JAPAN	AUSTRALIA	OTHER	
E18a (cont'd) Exhaust emissions (Euro-3)	1/1/2001 (Passenger cars & Class I)	98/69/EC. annex 1, para. 5. (Phase 1 limits)	Tier 2 (Note 13)	—	—	—	—	<p>“Diesel passenger vehicle” means a vehicle of category M1 the maximum mass of which exceeds 2000kg, fitted with a compression ignition engine, and which is</p> <ul style="list-style-type: none"> ▪ constructed or adapted to carry more than 6 occupants inc. the driver, or ▪ an off road vehicle as defined in annex 2 to the 1970 Directive.
	1/1/2002 (Category M1 other than passenger cars, Class II & Class III)	“	—	—	—	—	—	
	1/1/2003 (until this date a diesel passenger vehicle is treated as a vehicle of category N1)	“	—	—	—	—	—	

Annex 1

Enhanced SVA Requirements including Comparable* Non-European Standards

SUBJECT	DATE OF MANUFACTURE	EUROPEAN STANDARD (EC or ECE EQUIVALENT)	COMPARABLE NON-EUROPEAN STANDARDS					NOTES
			UNITED STATES	CANADA	JAPAN	AUSTRALIA	OTHER	
E18a (cont'd) Exhaust emissions (Euro-4)	1/1/2006 (Passenger cars & Class I)	98/69/EC, annex 1, para. 5, (Phase 2 limits)	—	—	—	—	—	
	1/1/2007 (Category M1 other than passenger cars, Class II & Class III)	"	—	—	—	—	—	
E18b CO2 & Fuel consumption	1/1/97 (Category M1)	Directive 80/1268/EEC as last amended by 93/116/EC annex 1, para. 5. or ECE R. 101 para. 5. (Note 15)	—	—	—	—	—	Not applicable to a) Goods vehicles. b) Three wheeled vehicles. c) Vehicles adapted to category M1 that were previously an M2 or M3 passenger vehicle or a goods vehicle.

Enhanced SVA Requirements including Comparable* Non-European Standards

Annex 1

NOTES

1. "Light motor vehicles" anchorage strength requirements are only 80% of those for other vehicles, so these are unacceptable.
2. Seat belt anchorage standard is indicated on a plate fixed to the vehicle.
3. Seat belt anchorages may be approved to one of the following standards which are acceptable before 1/7/97:-
BSAU 48a; BSAU 140a (for seats with integral anchorages); FMVSS 210; Directive 82/318/EEC.
4. As an alternative to complying with this standard, 4x4 vehicles having a frame chassis (see 4a below) and forward-control vehicles (see 4b below), may comply with Jisha 899, Attachment 2 (Technical Standards for Steering System Impacts), providing the following conditions are met:-
 - (a) the steering column assembly, associated structure forward of the A-post and all other relevant items (eg engine) are identical to the EC type approved version of the same model, and
 - (b) the steering wheel is either fitted with an air-bag as original equipment or is identical to the EC type approved version.
- 4a. In the Japan Jisha 899, Attachment 11, these vehicles are defined as "motor vehicles that have a frame (referring to a uni-construction frame which secures the engine and suspension devices of the front and rear wheels) and are equipped with a power train system capable of transmitting power to all wheels".
- 4b. In the Japan Jisha 899, Attachment 11, these vehicles are defined as "motor vehicles in which the major part of the engine is located underneath the driver's or passenger compartment (motor vehicles in which the median point of the respective intersections at which two planes that pass through the forward end or backward end of the engine proper and are perpendicular to the longitudinal centre line of the motor vehicle, lies to the back of the most forward end of the windshield)".
5. Applies to passenger cars (category M1) from 1/1/96; forward-control vehicles and off-road vehicles from 1/1/2000; light goods vehicles having maximum gross weight less than 2700 kg from 1/7/2000.
6. This does not apply to vehicles having a steering column axis at an angle greater than 35 degrees to the horizontal.
7. Includes an alternative "occupant survival space" requirement which is not acceptable.
8. Applies to most cars but not vehicles mentioned in note 9 below.
9. Applies to forward-control passenger vehicles, off-road passenger vehicles and goods vehicles since 1/7/98.
10. "Passenger car" : category M1 vehicle which has a maximum gross weight not exceeding 2500kg.
11. "Class I" : goods vehicles (category N1) having a reference mass not exceeding 1305 kg.
"Class II" : goods vehicles (category N1) having a reference mass greater than 1305 kg but not exceeding 1760 kg.
"Class III" : goods vehicles (category N1) having a reference mass greater than 1760 kg.
"DI" : vehicles propelled by Direct Injection diesel engine
"LPG" : vehicles fuelled by Liquid Petroleum Gas
"CNG" : vehicles fuelled by Compressed Natural Gas.

Cont'd ▼

12. To demonstrate compliance with European requirements, only evidence of compliance with the Type 1 test (drive-cycle) is needed, provided proof of compliance with the USA, Canadian or Japanese standards is available.
13. "Tier 2" will be phased in for cars and light duty trucks up to 6000lb (2720kg) max. gross weight from model year 2004 to 2007 and for heavier vehicles up to 2009. Only vehicles meeting the 0.2 g/mile (0.125 g/km) NOx standard can be accepted as equivalent to Euro-3.
14. In addition to demonstrating compliance with this standard, vehicles which require to be fitted with one or more catalytic converters in order to comply, must be tested to the requirements of the basic SVA test (item 18 Exhaust Emissions (Spark Ignition) - cat test) for vehicles fitted with catalytic converters.
15. Values derived from European emissions (Euro-2 or later) Type 1 (drive-cycle) test are acceptable.

DRAFT

Annex

Standard SVA – Non-European & Other Acceptable Standards

Evidence that a vehicle complies with the following standards will be accepted instead of compliance with the indicated SVA requirements. This does not necessarily mean that these standards are equivalent to the SVA requirements.

NOTES

This information is provided for guidance only and the Vehicle Inspectorate retains the right to test the vehicle against the SVA requirements if they have any reason to doubt compliance with the indicated standard.

- U FMVSS = Federal Motor Vehicle Safety Standard
- C CMVSS = Canadian Motor Vehicle Safety Standards

SAE = Society of Automotive Engineers (standard)

EPA 40 CFR = Environmental Protection Agency, Code of Federal Regulation, Title 40

J The references 11-4-(digit) are the relevant sections of the Automotive Type Approval Handbook for Japanese Certification published by the Japan Automobile Standards International Centre in the respective years listed (1994 or 1997).

JIS Japanese Industrial Standard.

A1 Does not include opacity. Must display manufacturer's name or trademark. Windscreen to show 2080 and WHP. Other windows 2080T and CHT, L, LT, LCHT or HP.

I1 Does not include opacity. Must display manufacturer's name or trademark. Windscreen to show Z or LW. Other windows T, TW, Z, L, or LW.

SECTION IN MANUAL	SUBJECT MATTER	UNITED STATES (U)	CANADA (C)	JAPAN (J)		OTHER
				1994 REF	1997 REF	
1	Anti-theft	FMVSS 114	CMVSS 114	—	—	
2	Defrosting and demisting	FMVSS 103	CMVSS 103	11-4-33 (defrosting and demisting systems)	11-4-42 (defrosting and demisting systems)	
3	Wiper and washer system	FMVSS 104	CMVSS 104	—	—	
4	Seats and their anchorages	FMVSS 207	CMVSS 207	11-4-8 (seats and seat anchorages) (J1)	11-4-46 (seats and seat anchorages) (J1)	
5	Seat belts (paragraphs 5, 6 & 7)	FMVSS 209 (U1)	CMVSS 209 (C1)	—	—	
5	Seat belt anchorages (paragraphs 1 & 2)	FMVSS 210 including associated requirements of FMVSS 207 and 208	CMVSS 210 including associated requirements of CMVSS 207 and 208	11-4-10 (seat belt anchorages)	11-4-21 (seat belt anchorages)	
5	Installation of seat belts (paragraphs 3, 4, 8, 9 & 10)	FMVSS 208	CMVSS 208	—	—	
6	Interior fittings	FMVSS 201	CMVSS 201	11-4-6 (instrument panel) 11-4-7 (sun visors) 11-4-9 (seat backs) (J2)	11-4-19 (instrument panel) 11-4-45 (sun visors) 11-4-20 (seat backs) (J2)	
7	Radio-interference suppression	SAE J551	—	—	—	
8	Glass in windcreens and other windows outside	FMVSS 205 (U2)	CMVSS 205 (C2)	11-4-21 (window glass) JIS R3211	11-4-27 (window glass) JIS R3211	South Africa SABS 1191 SABS 1193 India IS2553 (Part2) 1992 (Note I1) Australia AS/NZS 2080 AS/NZS 2080T (Note A1)

Cont'd ▼

Standard SVA – Non-European & Other Acceptable Standards (cont'd)

Annex

SECTION IN MANUAL	SUBJECT MATTER	UNITED STATES (U)	CANADA (C)	JAPAN (J)	
				1994 REF	1997 REF
9	Lamps, reflectors and devices	—	—	—	—
10	Rear-view mirrors	—	—	—	—
11	Tyres	FMVSS 109 (U3) FMVSS 110 (U4)	CMVSS 110 (C4)	JIS D4201 (marking) JIS D4202 (dimensions) JIS D4230 (performance)	JIS D4201 (marking) JIS D4202 (dimensions) JIS D4230 (performance)
12	Doors, their latches and hinges	FMVSS 206	CMVSS 206	11-4-12 (door retention systems)	11-4-26 (door retention systems)
13	Exterior projections	—	—	—	—
14	Protective steering	FMVSS 203 (U5) FMVSS 204 (U6)	CMVSS 203 (C5) CMVSS 204 (C6)	11-4-1 (steering system impact) (J3)	11-4-6 (steering system impact) (J3)
15.2	Design & Construction – General (fuel filler diameter)	EPA 40 CFR Part 80.24	—	—	—
16	Brakes	FMVSS 135 or FMVSS 105 + ABS on rear wheels	CMVSS 135 or CMVSS 105 + ABS on rear wheels	11-4-29 (braking systems)	11-1 Chapter 2 Article 12, and 11-4-9 (braking systems)
17	Noise and silencers	California (SAE J986)	CMVSS 1106	—	—
18	Exhaust emissions	EPA 40 CFR Part 86 or California TLEV, LEV or ULEV	CMVSS 1100	11-4-20 (10 mode) 11-4-25 (10.15 mode) 11-4-28 (13 mode), and 11-7-33 (limit values)	11-4-29 (10 mode) 11-4-28 (10.15 mode) 11-4-30 (13 mode)
19	Smoke emissions	—	—	11-4-26 (10.15 mode: diesel particulate standard)	11-4-31 (10.15 mode: diesel particulate standard)
20	Speedometers	FMVSS 101	CMVSS 101	—	—

NOTES

J1 Does not address location of unlocking controls or automatic locking of seats.

J2 Other areas are not addressed.

J3 Only addresses steering wheel/column energy absorption requirement of paragraph 3.

U1 and C1 Automatic locking retractors are unacceptable on 3-point retractor belt, a retractor must operate on the diagonal section.

U2 and C2 Glass bearing the following marking complies with FMVSS 205 and CMVSS 205

- in the case of a windscreen – AS1 or AS10
- in the case of a window wholly or partly on either side of the drivers seat – AS1, AS2, AS10, AS11A
- in any other case – AS1, AS2, AS3, AS10, AS11A, AS14, AS15, AS16.

U3 Tyre speed capability may not be sufficient. It must be no less than the vehicle design speed (or fixed speed limiter speed, where fitted).

U4 and C4 Non-pneumatic spare tyres are illegal for use in Great Britain.

U5 and C5 FMVSS 203 and CMVSS 203 only addresses steering wheel requirement of paragraph 2 and steering column energy absorption requirement of paragraph 3.

U6 and C6 FMVSS 204 and CMVSS 204 only addresses steering column rearward movement requirement of paragraph 4.

Other Acceptable United States/Canadian Standards - Additional Information

This annex lists the Non-European and other standards that can be accepted instead of compliance with the requirements indicated within the "Standard" section of the Inspection Manual.

In respect of the United States/Canadian acceptable standards, the Federal Motor Vehicle Safety Standards (FMVSS)/Canadian Motor Vehicle Safety Standards (CMVSS), which are listed in the annex under their appropriate reference numbers, evidence of vehicle compliance may be provided by a declaration on the manufacturer's plate indicating that the vehicle complied with all the relevant FMVSS/CMVSS requirements at the time of manufacture.

A vehicle displaying this statement is considered acceptable in respect of all the subjects for which there is a standard listed in the annex unless evidence suggests otherwise, e.g. the plate has been tampered with, the vehicle has been subject to modification.

However, in respect of item 16 "Brakes", if the vehicle does **not** have an antilock system on the rear axle it will be necessary to obtain documentary evidence from the manufacturer of compliance with FMVSS 135 / CMVSS 135 in order to be acceptable. (compliance with FMVSS 105 / CMVSS 105 not being an acceptable standard unless anti-lock braking is fitted to the rear axle).

In all cases evidence is only acceptable providing the vehicle has not been modified since manufacture such that compliance with the FMVSS/CMVSS may be affected. (Tyres/Glazing being particularly prone to being changed at some point after manufacture).

Passenger vehicles displaying a statement of compliance that show **no signs of modification** will **only need to be examined in respect of**;

- a) 5 Seat Belts (to ensure there are no Automatic Locking Retractors fitted and that 3 point retractors work on the diagonal section of the belt)
- b) 8 Glazing
- c) 9 Lamps & Reflectors
- d) 10 Rear View Mirrors
- e) 11 Tyres
- f) 13 Exterior Projections
- g) 16.5 Brakes (if no ABS on rear axle)
- h) 19 Smoke Emissions (if applicable)

Goods vehicles displaying a statement of compliance that show **no signs of modification** will **only need to be examined in respect of**;

- a) 16.5 Brakes (if no ABS on rear axle)
- b) 19 Smoke Emissions (if applicable)
- c) 22 Manufacturer's Plate.

Modification after manufacture is likely in the case of a Limousine, which in most cases will have been converted from a standard saloon.

Some conversions are carried out on chassis that are built for the purpose. In such cases a statement of compliance with the FMVSS/CMVSS will be required from the vehicle converter, but this will only be acceptable if there is **evidence to confirm that the converter is authorised by the manufacturer.**

In the case of Ford vehicles these conversions are known as QVM authorisations/conversions, in the case of General Motors, CVM.

Vehicles converted by non-authorised converters, or statements of compliance from non-authorised converters will not in isolation prove compliance.

Anti-theft Device 1

Application	Procedure and Standards	Reasons for Failure
<p>All vehicles except</p> <ol style="list-style-type: none"> a. Goods vehicles b. Passenger vehicles that comply with the requirements of item E1 of the ESVA requirements and having a date of manufacture on/after 1 October 1998 	<ol style="list-style-type: none"> 1. Check, in addition to the normal "ignition" switch, the vehicle is permanently fitted with an anti-theft device that can be activated to prevent the vehicle being driven or moved under its own power. The device may be mechanical, electrical or electronic or a combination of these. 2. Check each anti-theft device <ol style="list-style-type: none"> a. is operational b. does not operate on a part of the braking system c. which incorporates a mechanical part that acts upon a system used to control the vehicle (eg steering system) <ol style="list-style-type: none"> i. cannot be activated while the engine is running ii. does not allow the engine to be started before the device has been deactivated iii. has an actuation, which is a distinct and separate function from that of stopping the engine. <p>NOTE: A steering lock that is permanently inoperative shall not be considered to be an anti-theft device.</p>	<ol style="list-style-type: none"> 1. An anti-theft device not fitted. 2. An anti-theft device <ol style="list-style-type: none"> a. inoperative b. operates on a part of the braking system c. incorporating a mechanical part that acts upon a system used to control the vehicle <ol style="list-style-type: none"> i. can be activated while the engine is running ii. allows the engine to be started before the device is deactivated. iii. the activation of which is not a separate function from that of stopping the engine.

Defrosting/Demisting 2

Application	Procedure and Standards	Reasons for Failure
<p>All vehicles except</p> <ol style="list-style-type: none"> a. Goods vehicles b. vehicles not equipped with a windscreen through which the driver must look to obtain a view from his normal seated position, eg <ul style="list-style-type: none"> ▪ a fully opening windscreen ▪ a windscreen, the top edge of which is positioned below a horizontal plane as defined in the annex to this section. 	<ol style="list-style-type: none"> 1. Check the vehicle is fitted with a system/systems capable of defrosting and demisting the windscreen to allow the driver an adequate view of the road in front and forward of the nearside and offside of the vehicle. <p>A system using warm air to clear the screen must employ fan assistance and ducting to direct the air onto the screen, to ensure effective operation under cold weather conditions.</p> <p>An electrically heated screen must provide adequate heat and distribution to ensure effective operation.</p> <p>NOTE: The fitting of a device not permanently incorporated into the vehicle structure ie. adhered to the windscreen or body surface shall not be considered as a "system fitted to the vehicle."</p>	<ol style="list-style-type: none"> 1. A defrosting and/or demisting system <ul style="list-style-type: none"> ▪ not fitted. ▪ inoperative. ▪ not capable of clearing a sufficient area of the screen to allow the driver an adequate view. ▪ that uses warm air to clear the screen is not fan assisted.

Seats and Anchorages 4

Application	Procedure and Standards	Reasons for Failure
<p>All vehicles except</p> <ol style="list-style-type: none"> a. Goods vehicles. b. Disabled Person's vehicles in any seating position that is fitted with a seat designed for a person with a disability. c. in seating positions where there are, <ul style="list-style-type: none"> ▪ folding (tip-up) seats intended for occasional use and normally folded out of the way ▪ seats not designated for normal use while the vehicle is travelling on a road. <p>NOTE: Care must be taken in assessing whether seats are by manufacture intended for everyday use with the ability to be folded for additional luggage space or intended for occasional use.</p> <p>Seats for everyday use should not be considered "occasional" seats.</p> <ol style="list-style-type: none"> d. in seating positions where there are side-facing or rearward-facing seats. 	<ol style="list-style-type: none"> 1. Check each forward facing seat is firmly attached to the vehicle structure. <p>Seats are required to be secured firmly to the chassis or other obvious load bearing parts of the vehicle structure.</p> <p>If attached to a non-metallic floor pan separate from the chassis, adequate support to spread the load of the anchorage is required, eg spreader plates/stiffening ribs etc.</p> <p>NOTE 1: In respect of a seat that comprises of a "lift-out" backrest and/or squab it will be considered secure providing, when in the operational position, it is located such that there is no possibility of lateral or longitudinal movement within the vehicle.</p> <p>NOTE 2: On a seat to which a seat belt is mounted (integral seat belt) consideration must be given to the seat mounting as part of the seat belt anchorage.</p> 2. Check that each seat, seat back adjustment and seat displacement system incorporates an automatic locking system which operates in all positions provided for normal use. <p>NOTE: A seat/seat back INERTIA locking device is acceptable, ie a device that operates during the deceleration of the vehicle.</p> 3. Check each seat fitted with a displacement device to facilitate access by passengers is fitted with an unlocking control which is accessible from outside the vehicle when the door is open. <p>Where the seat immediately behind the seat concerned is designated as suitable for an adult, the unlocking control must also be easily accessible from this position.</p> 	<ol style="list-style-type: none"> 1. <ol style="list-style-type: none"> a. A seat mounting is insecure or of inadequate strength. b. The vehicle structure around a seat mounting point is of inadequate strength to support the load likely to be imposed. 2. A seat adjustment or displacement system locking device <ul style="list-style-type: none"> ▪ not fitted where necessary to prevent movement of the seat or a part of the seat ▪ insecure ▪ not locking automatically in each position provided for normal use. 3. A seat displacement device locking control <ul style="list-style-type: none"> ▪ inaccessible ▪ inoperative ▪ insecure.

Seat Belts and Anchorages

5

Application	Procedure and Standards	Reasons for Failure																											
<p>All vehicles except</p> <p>a. Goods vehicles,</p> <p>b. Passenger vehicles subject to the requirements of item E5a of the "Enhanced SVA Requirements" where the requirements of items 1 and 2 (anchorages) do not apply.</p> <p>c. Passenger vehicles that comply with the requirements of item E5b of the ESVA requirements and having a date of manufacture after 30 June 1997 where the requirements of items 3, 4, 5, 6, 7, 8 and 9 (belt installation) do not apply.</p> <p>NOTE: Exemption item 'c' does not apply to a Disabled Person's vehicle</p> <p>i) in a seating position where an anchorage has been fitted after manufacture of the original vehicle, or</p> <p>ii) in a seating position fitted with a disabled person's belt.</p> <p>d. Disabled Person's vehicles where the requirements of items 3, 5, 10b and 10c shall not apply in positions where a disabled person's belt is fitted.</p> <p>e. Motor Caravans, Motor Ambulances and Hearses where the requirements of</p> <p style="text-align: right;">Cont'd ▼</p>	<p>1. Check each seating position is fitted with the required number of anchorage points</p> <ul style="list-style-type: none"> ▪ for the type of belt fitted; and ▪ to meet the minimum requirement. <div style="border: 1px solid black; padding: 5px; margin: 10px 0;"> <p style="text-align: center;">Minimum Number of Anchorage Points - 3 wheeled vehicles with a body (see note 2), and 4 or more wheeled vehicles</p> <table border="1" style="width: 100%; border-collapse: collapse;"> <thead> <tr> <th colspan="3">Front</th> <th colspan="2">Rear</th> </tr> <tr> <th>Driver</th> <th>Centre</th> <th>Passenger</th> <th>Outboard Seats</th> <th>Centre Seats</th> </tr> </thead> <tbody> <tr> <td style="text-align: center;">3</td> <td style="text-align: center;">2 <i>(see Note 1)</i></td> <td style="text-align: center;">3</td> <td style="text-align: center;">2</td> <td style="text-align: center;">2</td> </tr> </tbody> </table> </div> <div style="border: 1px solid black; padding: 5px; margin: 10px 0;"> <p style="text-align: center;">3 wheeled vehicle without a body (see note 2)</p> <table border="1" style="width: 100%; border-collapse: collapse;"> <thead> <tr> <th colspan="2">Front</th> <th colspan="2">Rear</th> </tr> <tr> <th>Driver's saddle seat position (see note 3)</th> <th>Any conventional seating position</th> <th>Saddle seat position (see note 3 & 4)</th> <th>Other rear seats</th> </tr> </thead> <tbody> <tr> <td style="text-align: center;">Nil</td> <td style="text-align: center;">2 <i>(see Note 1)</i></td> <td style="text-align: center;">Nil</td> <td style="text-align: center;">2</td> </tr> </tbody> </table> </div> <p>NOTE 1: The front centre seat will require 3 anchorages where the windscreen is located</p> <ul style="list-style-type: none"> ▪ in the case of a fixed (non-sliding) seat, within 840mm. of the seat reference point ▪ in the case of a sliding seat, within 840mm. of the seat reference point when the seat is 127mm forward of its rearmost position. (For seat reference point, see Annex 4). <p style="text-align: right;">Cont'd ▼</p>	Front			Rear		Driver	Centre	Passenger	Outboard Seats	Centre Seats	3	2 <i>(see Note 1)</i>	3	2	2	Front		Rear		Driver's saddle seat position (see note 3)	Any conventional seating position	Saddle seat position (see note 3 & 4)	Other rear seats	Nil	2 <i>(see Note 1)</i>	Nil	2	<p>1. An anchorage point missing.</p> <p style="text-align: right;">Cont'd ▼</p>
Front			Rear																										
Driver	Centre	Passenger	Outboard Seats	Centre Seats																									
3	2 <i>(see Note 1)</i>	3	2	2																									
Front		Rear																											
Driver's saddle seat position (see note 3)	Any conventional seating position	Saddle seat position (see note 3 & 4)	Other rear seats																										
Nil	2 <i>(see Note 1)</i>	Nil	2																										

5 Seat Belts and Anchorages (cont'd)

Application	Procedure and Standards	Reasons for Failure
<p>item 1 shall only apply to seating positions where there is a seat intended for use while the vehicle is travelling on a road.</p> <p>f. Armoured vehicles where the requirements of items 1 and 3 only shall not apply where it can be demonstrated that it is impossible to comply due to its special purpose.</p> <p>g. in seating positions where there are folding (tip-up) seats intended for occasional use and normally folded out of the way; side facing or rear facing seats, where the requirements apply only to optional anchorages/belts that are fitted.</p> <p>NOTE: Care must be taken in assessing whether seats are by manufacture intended for everyday use with the ability to be folded for additional luggage space or intended for occasional use.</p> <p>Seats for everyday use should not be considered "occasional" seats.</p>	<p>NOTE 2: "Body" means a structure comprising of one or more panels, with or without a roof, that encloses the passenger compartment.</p> <p>NOTE 3: "saddle seat position" means a vehicle the seating arrangements of which include saddle type seats which are straddled by the driver and any pillion passenger seated upon the same longitudinal plane as the driver and immediately behind them.</p> <p>NOTE 4: Only applies to a seat immediately behind a "sit astride" driver's seat along the same longitudinal plane.</p> <p>2. Seat belt anchorage points must comply with the strength and location requirements of Directive 76/115 EEC, or to an equivalent safety standard.</p> <p>Check ALL anchorage points, including those that have NO belt fitted, and the surrounding vehicle structure and assess the load bearing capabilities. The anchorage and surrounding structure must be of adequate strength to withstand the load likely to be imposed by the torso in the event of a vehicle frontal impact. On seats to which seat belts are directly mounted (integral seat belts) consideration must be given to the seat mounting as a belt anchorage point (see Annex 1).</p> <p>NOTE 1: Materials and construction methods must be taken into account.</p> <p>NOTE 2: Comparable methods to that of a known approved vehicle type may be acceptable. Evidence that the vehicle is of identical structure to a vehicle which has been demonstrated to comply with the requirements may be taken to confirm compliance.</p> <p>NOTE 3: Vehicles (typically "people carriers" of 5 - 8 seats) may be fitted with seats that were not produced by the vehicle manufacturer but were</p> <p style="text-align: right;">Cont'd ▼</p>	<p>2. A seat belt anchorage or the surrounding vehicle structure is of inadequate strength and likely to fail.</p> <p style="text-align: right;">Cont'd ▼</p>

Seat Belts and Anchorages (cont'd)

Application	Procedure and Standards	Reasons for Failure
	<p>produced by or for the vehicle converter, being of the type used in larger PSVs e.g. having a frame of tubular design, (generally having separate bolt-on legs) and onto which the seat belts are mounted.</p> <p>Where a vehicle is presented with this type of seat, the presenter will be required to provide evidence that the seats of this type fitted to the vehicle meet the requirements for an M1 category vehicle. This should be in the form of a declaration from the vehicle converter or seat manufacturer making reference to the vehicle concerned, confirming that the seats fitted (other than the original vehicle manufacturer's seats) meet the strength and positional requirements of Directive 76/115/EEC for a category M1 vehicle, and supported by documentary evidence of the seat test results.</p> <p>Where the evidence provided relates to the seat only, consideration must be given to the seat mounting as a belt anchorage point.</p> <ol style="list-style-type: none"> 3. Check each seat requiring a seat belt is fitted with a belt of the appropriate type (see Annex 2 and 3) 4. Check each seat belt is secured <ul style="list-style-type: none"> ▪ to the vehicle structure or where the belt is integral with the seat to the seat structure ▪ using a fixing of adequate strength ▪ such that it can be separated from the anchorage without causing damage to the anchorage. <p>NOTE 1: A suitable single bolt fixing of adequate strength would be, for example, a bolt of at least 11mm (7/16") diameter of grade 8.8 (the grade may not be shown on a bolt produced for a seat belt anchorage).</p> <p style="text-align: right;">Cont'd ▼</p>	<ol style="list-style-type: none"> 3. A seat belt missing or of the wrong type. 4. A seat belt <ul style="list-style-type: none"> ▪ not securely fixed to the vehicle structure or, where the belt is integral with the seat, to the seat structure ▪ fixing of inadequate strength ▪ cannot be separated from the anchorage without causing damage to the anchorage. <p style="text-align: right;">Cont'd ▼</p>

5 Seat Belts and Anchorages (cont'd)

Application	Procedure and Standards	Reasons for Failure
	<p>Other bolt fixings may be acceptable providing they are of equivalent strength.</p> <p>Two adjacent seat belts may be secured by one bolt. In this case consideration must be given to the additional loads on the anchorage.</p> <p>NOTE 2: In order that a seat belt can be separated from the anchorage without causing damage to the anchorage, for example a mounting in the side of a tube or box section, it is a requirement that the bolt is secured into a "fixed" threaded hole or captive nut. (The presenter may be required to demonstrate this condition is met). The bolt may be secured into an alternative fixing, e.g. a lock nut of suitable strength, where access is provided to the "rear" of the mounting to enable separation/re-attachment of the belt.</p> <p>5. Check all seat belts (mandatory and optional) fitted, either</p> <p>a. bear one of the following approval markings confirming compliance</p> <ul style="list-style-type: none"> ▪ a designated approval mark ("E" or "e") ▪ a British Standard marking for Passive Belt Systems (BSAU183:1983) ▪ a British Standard marking for a harness belt (BS3254:1960 or BS3254 Part 1 1988) ▪ a specification marking which (in association with documentation where necessary) demonstrates that the belt satisfies the requirements of a European standard corresponding to any of the British Standards for a seat belt for use by an adult as referred to in Regulation 47 of The Road Vehicles (C & U) Regulations, or <p style="text-align: right;">Cont'd ▼</p>	<p>5.</p> <p>a. A seat belt</p> <ul style="list-style-type: none"> ▪ not permanently marked with an acceptable approval marking, and ▪ does not have the equivalent characteristics to that of a belt approved for the same category of vehicle. <p style="text-align: right;">Cont'd ▼</p>

Seat Belts and Anchorages (cont'd)

Application	Procedure and Standards	Reasons for Failure
	<p>b. have equivalent characteristics to that of a belt approved for the same category of vehicle.</p> <p>Check the characteristics include</p> <ul style="list-style-type: none"> i. the webbing is of an equivalent type of material and where it is likely to come into contact with the body of the wearer is at least 46mm (33mm in the case of a harness belt shoulder straps) in width. ii. all components are suitably protected against corrosion, eg plated or coated. iii. the locking mechanism, ie the buckle, when both under load and not under load, can be released by a single movement in one direction by either hand. iv. other than a harness belt the locking mechanism contact area with the body of the wearer is not less than 46mm in width. v. for a static seat belt there is a manual adjusting device <ul style="list-style-type: none"> ▪ accessible to the wearer when seated ▪ convenient and easy to use ▪ capable of being tightened with one hand. vi. for a retracting belt <ul style="list-style-type: none"> ▪ the retractor locks when the vehicle is subject to deceleration, tilt or the belt is pulled quickly from the retracting mechanism. <p style="text-align: right;">Cont'd ▼</p>	<p style="text-align: right;">Cont'd ▼</p>

5

Seat Belts and Anchorages (cont'd)

Application	Procedure and Standards	Reasons for Failure
	<p>6. Fasten each belt locking mechanism (buckle) and try to pull the locked section apart. On retracting seat belts, check that, with the mechanism fastened and the seat unoccupied, excess webbing is wound into the retractor unit.</p> <p>NOTE: Some types of retracting belt might need help before they retract.</p> <p>Operate the release mechanism while pulling on the belt to check that it releases when required.</p> <p>7. Where a lap/diagonal retracting belt is fitted, check the position and operation of the retractor mechanism.</p> <p>NOTE 1: A belt may be fitted with retractor mechanisms on both lap and diagonal sections. If fitted with a single retractor mechanism it must act initially on the diagonal (shoulder) section.</p> <p>NOTE 2: An “automatically locking” retractor (ie one that allows extension of the belt to the desired length and when the buckle is fastened locks on retraction but then prevents subsequent forward movement by the wearer, unlike a typical inertia reel belt), is not permitted unless the feature is only provided after full extension of the belt from the retractor, ie for use as a child restraint.</p> <p>8. Check the vehicle structure, fitments and components near each belt for sharp edges likely to cause abrasion or damage to the belt during normal use.</p> <p>9. Check each lap belt, passive belt or three-point belt has provision for the safe and convenient storage of the belt when not in use.</p> <p>NOTE: An independent belt storage facility is only necessary where it is needed to ensure the belt is always accessible for use.</p>	<p>6.</p> <ol style="list-style-type: none"> a. A seat belt locking mechanism (buckle) does not secure or release the belt as intended b. A retractor mechanism does not retract the webbing sufficiently to remove all the slack from the belt with the locking mechanism fastened and the seat unoccupied <p>NOTE: In doubtful cases, this should be checked with the seat set in its rearmost position.</p> <p>7. A retractor mechanism</p> <ul style="list-style-type: none"> ▪ acts initially on the lap section of the seat belt (unlike a typical European design) ▪ of the “automatically locking” type (other than in the case of a child restraint - see Note 2 in Procedure and Standards). <p>8. A vehicle part or attachment has a sharp edge likely to cause abrasion or damage to a belt.</p> <p>9. A seat belt has no provision for its safe and convenient storage</p>

Cont'd ▼

Cont'd ▼

Seat Belts and Anchorages (cont'd)

Application	Procedure and Standards	Reasons for Failure
	<p>10.</p> <p>a. While sitting in each seat in turn, and wearing the seat belt, secured and correctly adjusted, check the position of the webbing on the torso and the location of the effective belt anchorage points in relation to the seated body position (see Note 2).</p> <p>The seat belt must be capable of effectively restraining the occupant</p> <ul style="list-style-type: none"> ▪ by the position of the lap belt (due to anchorage location) passing over the pelvic region ▪ in the case of a harness belt or three point belt, by being positioned across the shoulder so that it does not slip off the shoulder of the occupant. <p>NOTE 1: Where the seat is adjustable, this check must be carried out with the seat secured in the rearmost position and with the back rest in the normal driving position, in any case at a rearward angle of not more than approximately 25° from the vertical.</p> <p>NOTE 2: The effective belt anchorage is the actual anchorage point to the vehicle unless a change of direction of the belt to the wearer is produced by a fixed intermediate device, for example, a belt guide fitted to the upper part of a seat back.</p> <p>NOTE 3: Where a seat incorporates a belt guide that creates the "effective belt anchorage" consideration must be given to the strength of the seat back in relation to the loading to which it may be subject, (this being dependent on the position of the actual anchorage). The requirements of item 2 should be applied to the effective anchorage location</p> <p style="text-align: right;">Cont'd ▼</p>	<p>10.</p> <p>a. A seat belt effective anchorage location</p> <ul style="list-style-type: none"> ▪ does not enable the lap belt to rest on the pelvic area of the body. ▪ of the lap belt section is not to the rear of a vertical line taken at the point where the belt passes over the body. ▪ of the diagonal section (where applicable) <ul style="list-style-type: none"> - does not enable the belt to pass over the shoulder of the wearer - is such that the belt is likely to slip off the shoulder ▪ of the diagonal section (where applicable) is not to the rear of the front of the body/ shoulder of the wearer when seated in a relaxed upright position. <p style="text-align: right;">Cont'd ▼</p>

5

Seat Belts and Anchorages (cont'd)

Application	Procedure and Standards	Reasons for Failure
	<p>in the same way as it is applied to the actual anchorage albeit that the loading will be different.</p> <ul style="list-style-type: none">b. On a harness or three point belt, check that the height of the effective upper anchorage position (measured vertically above the reference point as described in Annex 4) is 450mm or more.c. On a lap/diagonal belt, check that the upper anchorage location is 140mm or more (measured in a transverse plane) from the longitudinal centre line of the relevant seat (see Annex 4).	<ul style="list-style-type: none">b. A harness or three point belt effective upper anchorage location is less than 450mm above the reference point.c. A lap/diagonal belt upper anchorage location is less than 140mm from the longitudinal centre line of the seat.

In a severe accident, the seated occupant can exert huge loads upon their seatbelts (in the region of 1.5 tonnes for a 75kg person). Seatbelt anchorages together must withstand these large loads from the seatbelts. These loads in turn must be dissipated by the vehicle structure.

In assessing the strength of the anchorages, it is essential to consider

- the vehicle structure in the immediate vicinity of the anchorage, and
- the parts of the vehicle structure into which the loads from the anchorages will be dissipated.

These large loads will act in several directions as shown in fig. 1.

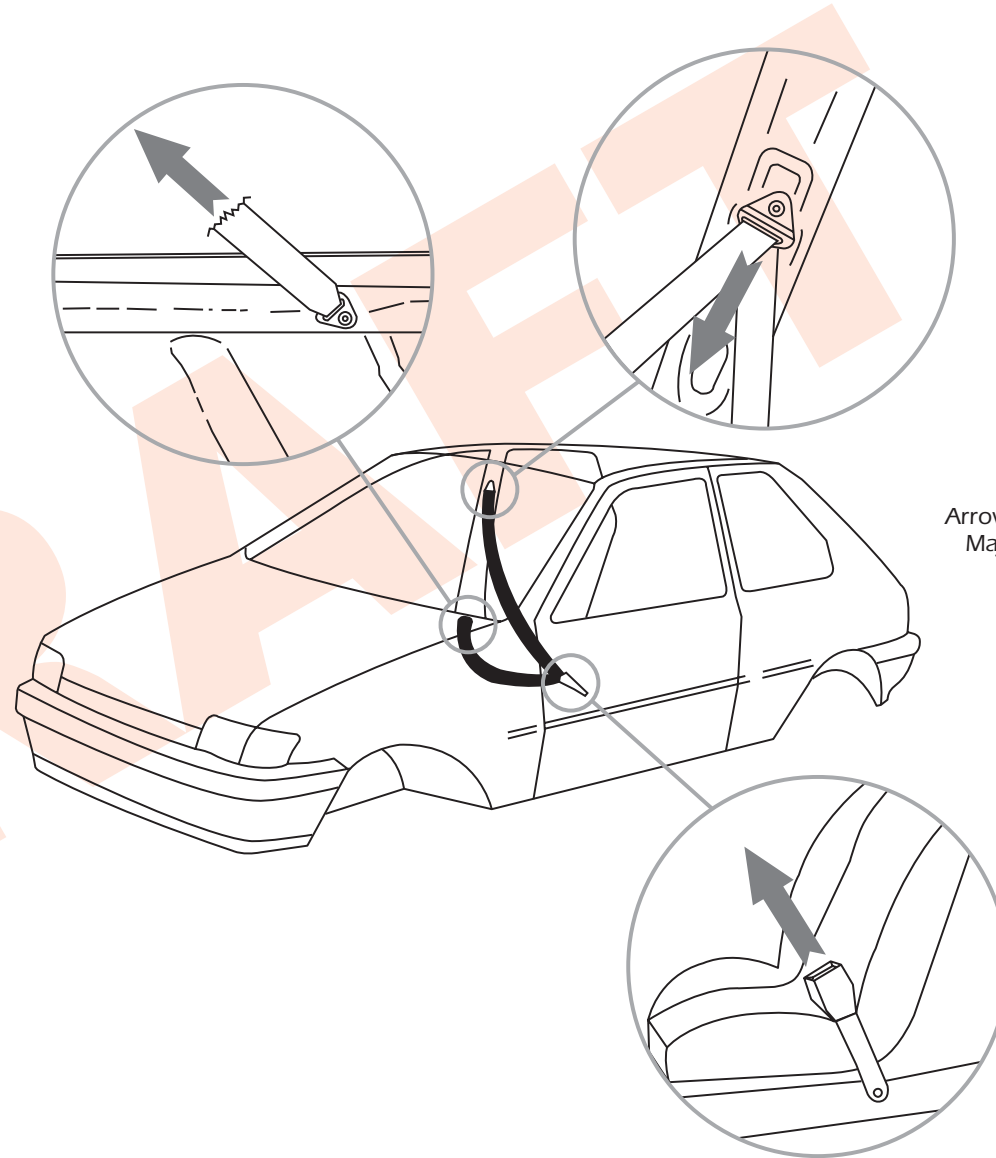

Fig. 1
Arrows Show Directions of Major Loads on Seat Belt Anchorages.

5 Seat Belt Anchorage Strength Assessment (cont'd) Annex 1

1. ALL VEHICLES

What to look for:

- Evidence that anchorages in a vehicle of the same, or a very similar type have been subjected to a seatbelt anchorage strength test to "European Standards" by a recognised authority. This may be acceptable where there is clear evidence that the structure is identical to the vehicle originally tested.
- Welding should appear neat and of good quality; whilst it is impossible to judge the quality of a weld just by looking at it, messy welding is rarely strong welding.
- Bolts used in structural areas should be of grade 8.8 or better. Such bolts will be marked 8.8 or 12.9 on the hexagonal head, however, cap-head bolts or $\frac{7}{16}$ " UNF seat belt anchorage bolts (with an anodised finish) not marked in this way may normally be considered to be of equivalent strength. Bolts should be M8 or larger.
- Threaded bushes should be welded (at both ends) through the tube, and not end mounted on the surface. (A threaded bush may be attached by its side surface to a structural component) See Fig 2a.

Cause for Concern:

- Welds of poor appearance, gaps or visible lack of penetration.
- Anchorages in thin and/or flat panels with little stiffness or re-inforcing structure or in thin walled tube.
- Low grade bolts (less than grade 8.8).
- Insufficient bolt capacity, eg number of bolts and/or diameter of bolts.

2. Monocoque Construction

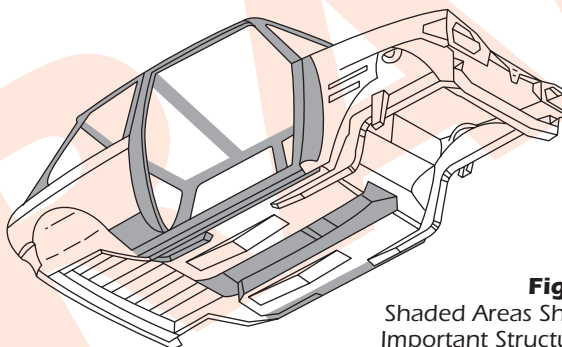
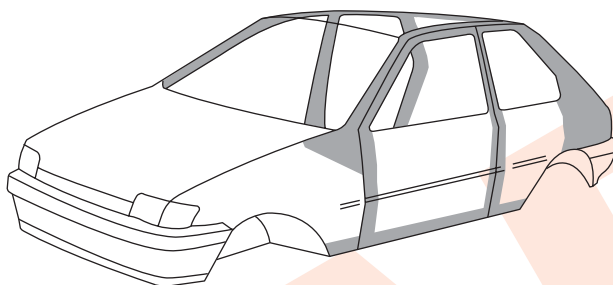
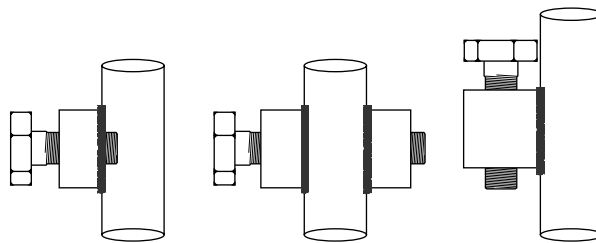

Fig. 2
Shaded Areas Show Important Structure.



Unacceptable

Acceptable

Acceptable

Fig. 2a

2i. Steel Monocoques

What to look for:

- Structural box sections.

2ii. Composite Monocoques.

Composite materials such as glass re-inforced plastic (GRP - also known as fibreglass) are fairly common in the specialist vehicle industry.

What to look for:

- Box Sections with heavy lay up (i.e. material thickness).
- Re-inforced areas, for example using folded metal box sections laminated into the vehicle structure.
- Material lay-up of good quality with absence of air bubbles.
- $\frac{7}{16}$ " UNF threaded fixing of suitable surface area, or welded to a spreader plate of suitable surface area.

Cause for concern:

- Threaded fixing/spreader plate of insufficient surface area.
- Threaded fixing and/or spreader plate only retained by a thin layer of laminate on the outer surface of the structure.
- Material lay-up poor with obvious air bubbles or delamination (separation of material layers).
- Cracking or flexing of structural areas.
- Loads from anchorages being transmitted to weak areas of vehicle.

Cont'd

Annex 1 Seat Belt Anchorage Strength Assessment (cont'd) 5

3. Anchorages on Steel Chassis

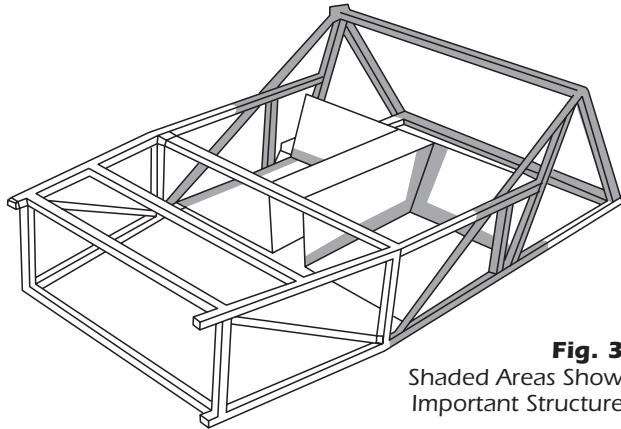

Fig. 3
Shaded Areas Show Important Structure

What to look for:

- Triangulation and bracing will provide strength and spread the loads effectively into the chassis.
- Upper anchorage must be adequately braced to strong areas of the chassis.
- Threaded seatbelt anchorage fastening should be welded into tubes or onto plates of sufficient thickness.

Cause for Concern:

- Absence of sufficient structure to transmit loads from anchorages.
- Absence of bracing or triangulation from upper anchorage structure.

4. Steel Chassis With Anchorages on Roll Cage

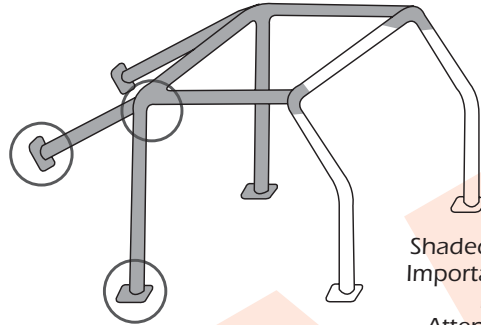

Fig. 4
Shaded Areas Show Important Structure.
Pay Particular Attention to Joints (Examples Circled).

What to look for:

- Triangulation and bracing which will provide strength and spread the loads effectively into the chassis.
- The joint where the roll cage joins the chassis and the chassis itself must be sufficiently strong to withstand the loads from the anchorages.
- Upper anchorage must be adequately braced from near the anchorage to strong areas of the chassis.
- Threaded seatbelt anchorage fastening should be welded into tubes or onto plates of sufficient thickness.
- Bolted joints joining the cage to the chassis and parts of the cage to each other should be of sufficient strength.

Note: For guidance roll cages should ideally be manufactured of CDS steel tube dia 45mm x 2.5mm wall thickness OR dia 50mm x 2.0mm wall thickness. Bend radii should exceed 3 times the tube diameter. Where tubes are ovalised during bending, the ratio d/D should not be less than 0.9 (d =small diameter, D =larger diameter).

Cause for concern:

- Roll cage manufactured using aluminium.
- Poor bolted joints, or joints that could separate due to loads in anchorages.
- Insufficient bracing or bracing to upper anchorage too low.
- Roll cage material cracked or badly creased.
- Cage-to-chassis mounting plates of smaller thickness than cage wall thickness.
- Cage not attached to chassis, or insufficient joint strength.

5 Seat Belt Anchorage Strength Assessment (cont'd) Annex 1

5. Composite Structural Body With Anchorages on Integral Roll Cage.

What to look for:

- A combination of the strength characteristics of (2ii) and (4) above.
- Where a combination of the strength of the body and cage are used to strengthen the anchorages, body and cage should be joined at regular intervals.

Cause for concern:

- As (2ii) and (4) above.

6. Anchorages Integral With Seat Structure

What to Look For:

- Seats where the integral anchorage/s has been previously approved in a vehicle. In this case attention must still be paid to the method of fixing the seat in the vehicle.
- Seats fixed to vehicle structural areas, ie box sections etc.
- Use of spreader plates to spread loads into structural areas of the vehicle.
- Where lower anchorages are mounted on the seat structure, they should be welded or permanently fixed to the seat in a structurally strong area.
- Where the upper anchorage is mounted on the seat structure, the seat back must be braced to the lower seat structure. This bracing must begin as close as possible to the upper anchorage.
- Where the upper anchorage is mounted on the seat structure, the seat-to-floor fixing must be substantial to withstand the large leverage imposed upon it.
- Where the seat is mounted on runners, these must be of adequate strength.

Cause for Concern:

- Seats mounted on flat panels, non-structural areas of vehicle floor or open channel section material.
- Lack of load spreading plates.
- Seat frames constructed of thin wall circular section tube in areas receiving loading from anchorages.
- Upper anchorages on seat back without bracing to strong area of seat.

7. Pedestal Seats (seats mounted on box or tubular section legs) with Integral Belt Anchorages

In this situation, the seat itself becomes part of the belt anchorage and the loads generated on a belt must be dissipated through the seat frame and into the surrounding vehicle structure.

Typical vehicles fitted with such seats might include "People Carriers" and Taxi conversions.

During the anchorage Type Approval test, forces equivalent to approximately 3 tonnes **per seating position** are applied to the belt anchorages of all forward-facing seating positions. In the case of a double or triple seat, this might mean loads approaching the order of 9 tonnes could be transmitted through the seat pedestals and into the vehicle. In a seat with integral anchorages, this load must travel down the seat back and sides, into the pedestals and then into the floor of the vehicle. The height of the pedestals above the floor then acts as a lever causing the front seat legs to be pushed down into the vehicle floor and the rear seat legs to be pulled upwards out of the floor.

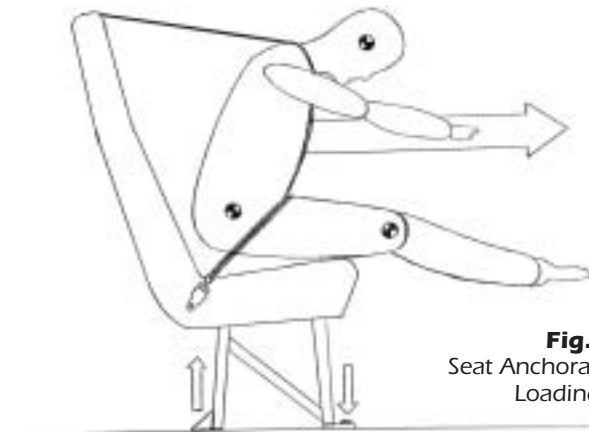

Fig. 5
Seat Anchorage
Loadings.

Annex 1 Seat Belt Anchorage Strength Assessment (cont'd) 5

Depending on the pedestal height, the forces being fed into the floor could be considerably larger than the 3 tonnes force applied to the seat belts.

On pedestals about 350mm high the upward load on the rear seat legs might well be in the region of 6 tonnes (three tonnes per seat pedestal).

In view of the extremely high loads, it is important that a thorough assessment of the load path from each anchorage to the vehicle structure is made. This will begin at each of the belt anchorages and might end some considerable distance away from the attachment of the seat to the vehicle.

There are a variety of ways in which a vehicle floor can be designed to cope with the loading from a seat with integral belt anchorages. One commonly used method is to secure the seats to a beam or box section or framework inside the vehicle, running the length of the saloon area. This framework is then attached to the vehicle in a variety of places spread over a large area and located close to strong points under the floor (such as junctions between chassis members). Such systems are difficult to inspect once the vehicle is assembled as the structure is normally concealed under a cosmetic "plywood" floor.

Another commonly used method is the use of load spreading plates above and below the vehicle floor. These plates effectively behave as large "washers" spreading the load from the seat pedestals into a surrounding area of vehicle floor.

Some vehicle converters choose to use a system of reinforcing members (typically channel or box section members) under the vehicle floor. The intention is to use these members in the same way as reinforcing members inside the vehicle

but without the increase in floor height and loss of headroom. The disadvantage of such a system is that in order to clear underfloor obstructions such as chassis members and running gear, the reinforcing members cannot be continuous and must have joints in them – which can weaken the overall structure.

a. What to Look For:

General requirements for all vehicles

- A test certificate from a recognised test authority must be provided to show that the seat itself or the seat and tracking (where this is fitted) is capable of meeting the strength and anchorage positional requirements of the Directive 76/115/EC as amended. It should typically include at least the following information:

Seat make and model,
Vehicle category (M1, M2 or M3),
Seat type (single /double or triple),
Belts fitted (3-point or lap),
Pedestal height,
Mounting details (ie on tracking or rigidly, mounted to a base plate).

- **ALL** the mounting holes provided in each pedestal for securing the seat to the vehicle or tracking must be utilised.
- **ALL** the mounting holes provided to secure any given length of tracking to the vehicle must be utilised.
- All tracking fasteners should be M8 grade 8.8 or better.
- tracking must be installed in a continuous length without joints.
- Seat or tracking mounting bolts that pass through hollow section reinforcing

members should be fitted with "anti crush tubes".

NOTE: Alternative mounting arrangements will be considered satisfactory where satisfactory documentary evidence of compliance can be provided by the vehicle presenter.

b. Fixed Single Seats

A typical single seat fixed directly to the vehicle floor is likely to require

- load spreading plates at least 100 x 100 x 4mm thick.
- spreader plates fitted between the front legs and the **inside** of the vehicle floor
- spreader plates between the rear leg securing nuts and the **underside** of the vehicle floor.

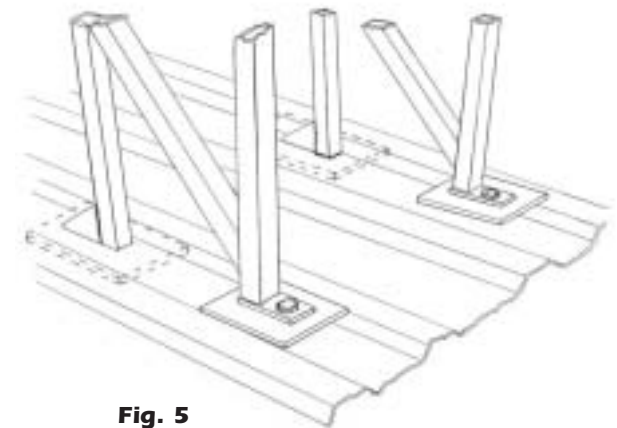

Fig. 5
Load Spreading
Plates.

5 Seat Belt Anchorage Strength Assessment (cont'd) Annex 1

Where the rear mounting bolts are located within 50mm of a chassis member, the plate may be folded (not reduced in size) to clear the obstruction and the fold should abut snugly against the chassis member.

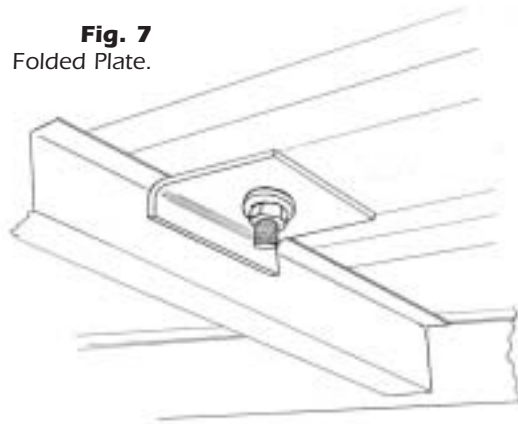

Fig. 7
Folded Plate.

Where two or more single seats each having separate pedestals are mounted within approximately 200mm of each other, additional reinforcement should be provided as well as the load spreading plates, or the size and thickness of the load spreading plates increased.

NOTE: In many cases the mounting bolts will pass through slotted holes in the load spreading plate to allow for adjustment. Suitable arrangements must be in place (eg oversized washers) to prevent the nut or the head of the bolt from pulling through the slot in the plate.

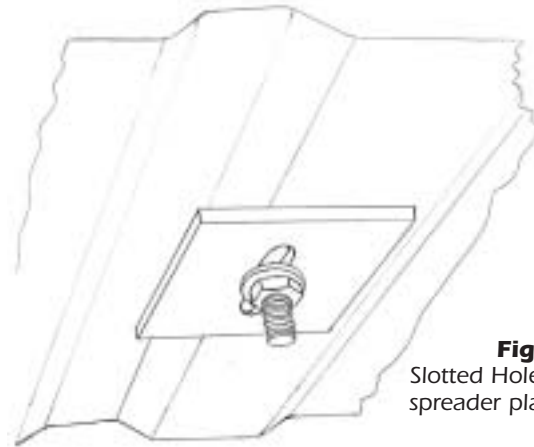

Fig. 8
Slotted Hole in
spreader plate.

Single seats with integral 3-point belt anchorages attached to the vehicle floor via offset or asymmetrical legs (ie to clear a wheelarch,) must be considered on a case-by-case basis. Documentary evidence from the seat manufacturer should be sought to confirm that the seat itself can withstand the forces required by the Directive when tested independently of the vehicle on its offset pedestals.

In vehicles modified to allow rear-access for a wheelchair via a ramp to a lowered central floor section having additional seats fitted either side of the lowered floor section, seats are often mounted directly to the floorpan either with very short pedestals or no pedestals at all. It is common for at least some of the original vehicle's belt anchorages to be used in combination with one or more of the anchorages on the new seat. The inspection should take into account the reduced floor loading resulting both from the shorter pedestals and (if applicable) from the relocation of the upper anchorage from the seat backrest to the vehicle pillar.

Where only **one** lower anchorage is attached to the seat, the effects of the asymmetrical loading should be considered.

Some vehicles, eg motorhomes and ambulances are equipped with swivel seats which may have some or all the belt anchorages attached to the seat itself. Such seats should only be inspected in their position of normal use when travelling.

c. Removable Single Seats

Removable single seats may be fitted to either

- “Low Profile” tracking or
- “Heavy Duty” tracking or
- to dedicated clamping mechanisms attached to the floor of the vehicle.

For the purposes of this inspection,

- “**Low Profile**” tracking can be regarded as any tracking system with a section depth of up to 30mm.
- “**Heavy Duty**” tracking can be regarded as any tracking system with an overall depth of 30mm or more.

(i) “**Low Profile**” tracking systems.

The seat fittings locate in cut-outs in the tracking and lock with either a plunger or “blade” arrangement.

In general, a typical single seat with three-point integral belt anchorages and mounted on a typical pedestal arrangement that is itself Directive compliant is likely to satisfy the Directive requirements as long as the tracking is

- supported in such a way as to prevent excessive distortion of the floor

Annex 1 Seat Belt Anchorage Strength Assessment (cont'd) 5

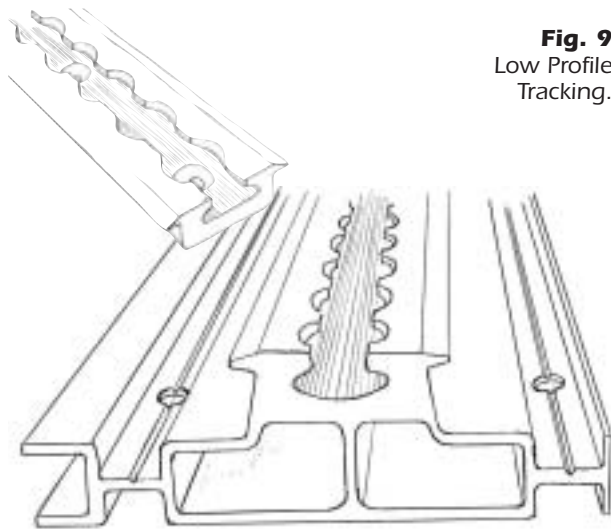

Fig. 9
Low Profile
Tracking.

- attached to the vehicle using 8mm (grade 8.8 or better) fasteners no more than approx. 100mm apart.
- either bolted to box or steel channel section and then secured to the vehicle floor, or secured by bolts going through the floor and into channel or box sections on the underside of the vehicle.

NOTE: Various proprietary load-spreading plates are marketed for this purpose but these are primarily aimed at the “M2” vehicle market for which the seat belt anchorage test loads are only half as great. Unless documentary evidence is provided to the contrary, simple load-spreading plates or washers should not be regarded as being satisfactory.

- (where secured into steel channel sections) secured into channel section of a minimum nominal size of 50x25x4mm which is orientated with the channel flanges facing downwards.

NOTE: The channel ends must be free of sharp edges, which may tear the vehicle floor under load.

Unless the tracking is secured to internal reinforcing members, a check should be made that the same number of fasteners are present above and below the vehicle floor. In cases where a fastener lies above a box section, heat shield, fuel tank or other obstruction, it must pass into an object of similar strength to the other reinforcing members.

- “Self-tapping” screws and “riv-nuts” are not considered as being of equivalent strength (unless documentary evidence can be provided).
- Seats should not be capable of being positioned such that the front or rear edge of either pedestal lies within 200mm of the end of a length of tracking.

(ii) **“Heavy Duty” tracking systems.** Although these differ in appearance, they all share the same principal feature – ie a much deeper section than the “low profile” tracking systems. These lengths of tracking have sufficient depth of section to resist the large bending loads applied during a seat belt anchorage test. As such, they generally require no reinforcement between themselves and the inside of the vehicle floor and only minimal reinforcement beneath the vehicle floor. Typically, such tracking is not secured at precisely defined intervals so that the converter is free to choose the pitch of the fasteners to miss underfloor obstructions such as chassis members. Often the tracking is secured by pairs of fasteners – one on each side of the centerline, rather than individual fasteners along its centerline.

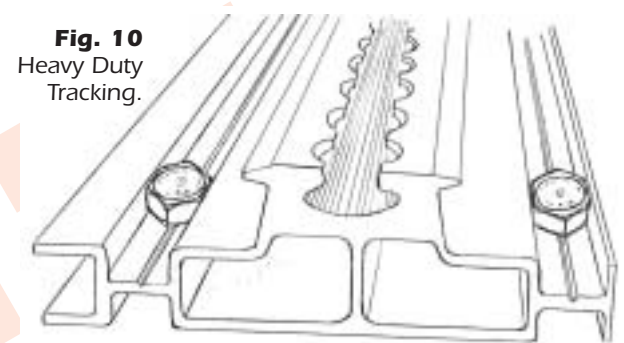

Fig. 10
Heavy Duty
Tracking.

“Heavy Duty” tracking should be secured

- with 8mm grade 8.8 (or better) fasteners at intervals of not more than 250mm.
- with fasteners passing through a mild steel load spreading plate at least 50 x 50 x 4mm thick or an equivalent arrangement.
- such that seats are not capable of being positioned with the front or rear edge of either pedestal within less than 200mm of the first or last group of fasteners securing any length of tracking.

(iii) **Seats with dedicated fixings.** Rear single seats in many mass-produced “people carrier” type vehicles are often removable. In general, these are attached to purpose-made latches set into the vehicle floor. If there is evidence to suggest that such an arrangement is not part of the original vehicle equipment, an assessment of the strength of the assembly should be made by comparison with a similar unmodified assembly.

5 Seat Belt Anchorage Strength Assessment (cont'd) Annex 1

d. Fixed double seats

Double seats fitted with integral three-point belts and **two or three pedestals** impart significantly higher loads into the vehicle floor than a single seat impacts. As a result, it is extremely difficult to restrain such a seat using simple reinforcements alone. Documentary evidence that the installation can satisfy the Directive requirements **in-vehicle** should be sought.

Where a double seat with integral three-point belt anchorages is fitted with **four or more pedestals**, approximately evenly spaced, a spreader plate extending at least the full width of the seat should be fitted between the front legs and the vehicle floor. Such a plate might typically be in the region of 5mm thick, 150mm long and at least the width of the complete seat (including cushions).

Angle or channel sections of similar or greater rigidity than the flat plate may also be used.

Where two pedestals are mounted within approx. 200mm of each other, additional reinforcement must be provided as well as the load spreading plates, or the size and thickness of the load spreading plates increased.

e. Removable double seats

Removable double seats with three point integral belt anchorages are rare. In general, such a seat fitted with two or three pedestals is unlikely to satisfy the Directive requirements in a vehicle as most currently available tracking systems will not withstand the loads required for a category "M1" vehicle. In all such cases, documentary evidence that the complete seat and tracking assembly has been successfully tested "in-vehicle" should be sought.

f. Fixed triple seats

It is common to fit triple seats across the rear of many taxi conversions and "people carrier" vehicles. It is not, generally, possible to secure such seats using simple reinforcements alone. If a triple seat is fitted with three-point integral anchorages, documentary evidence that the complete assembly has been successfully tested "in-vehicle" should be sought.

If some of the belt anchorages are located on the body structure (typically the outboard upper and lower anchorages), the load on the seat mountings will be correspondingly reduced. If the centre seating position is only equipped with a lap belt, the loads on the seat mountings are further reduced. In some cases, only the two anchorages from the centre seat belt and one of the lower anchorages from each of the outboard seating positions will transmit their load into the vehicle through the seat pedestals. Seats fitted with this arrangement of belt anchorages must be assessed on a case-by-case basis. In general terms, such a seat fitted with four pedestals (roughly evenly spaced) is likely to prove satisfactory if fitted with simple load spreading plates. If fewer pedestals are fitted (or more anchorages are located on the seat structure), additional reinforcement will be required.

g. Rear-Facing seats

Rear-facing single seats with integral belt anchorages are only required to withstand loads approximately **one third** of the magnitude of a forward-facing seat. As such, mounting arrangements can be significantly less substantial than those for forward-facing seats. In many cases, rear-facing seats are mounted on a bulkhead rather than free-standing. Often, the bulkhead structure will be impossible to assess due to the presence of trim on both surfaces. In

these instances, drawings or photographs of the structure should be sought. The bulkhead structure should be attached to the vehicle at least along its lower edge and sides. An assessment of the strength and number of such mountings should be made. The examiner must satisfy himself (as far as is reasonably practicable) that the attachment(s) of the bulkhead to the vehicle "B" pillars does not compromise the strength of the front seat upper belt anchorages. An inspection of the method used to attach the belt anchorages to the bulkhead (or seats) should also be made. If the belts are attached to the seats, their attachments to the bulkhead will be part of this inspection. It is common to only fit lap belts on rear-facing seats. The removal of an upper belt anchorage significantly reduces the load at the base of the seat during a test. This should be taken into consideration when assessing the structure.

h. Seats with integral Lap Belts

The fitting of a lap belt rather than a three point belt with its upper anchorage on the seat back is likely to lower the loads on the vehicle floor by approximately one third. For a typical "minibus style" single seat, the load acting to pull the rear legs out of the floor when fitted with a three-point belt is likely to be in the region of 6 tonnes. This would reduce to approximately 4 tonnes if the same single seat were to be fitted with an integral lap belt. In view of the reduction in floor loading, less reinforcement is likely to be required than for a seat with three integral anchorages.

NOTE: In cases where three anchorages are provided but only two are attached to the seat, the load on the pedestals could be reduced still further - possibly by as much as half.

Annex 1 Seat Belt Anchorage Strength Assessment (cont'd) **5**

i. Sliding Seats

Some seats are fitted to a system of “runners” so as to allow fore and aft adjustment or to provide two alternative positions of use. Some of the belt anchorages for such seating positions may be attached to the seat. Before making any assessment of the belt anchorages, documentary evidence should be sought to confirm that the seat and runner assembly is capable of satisfying the requirements of the Directive when tested **independently** of the vehicle. Once this has been confirmed, the installation of the seat in the vehicle can be assessed.

DRAFT

Three Wheeled Vehicles with a Body and Four or more Wheeled Vehicles

Vehicle Description - Effective Date	Seat Position		
	Driver's and "Specified Front Passenger's" Seat (See Note 1)	Other Front Seat	Forward Facing Rear Seats
1. Passenger vehicles and dual purpose vehicles with not more than 8 passenger seats. Prior to 1 April 1987. From 1 April 1987.	3 point belt (See Notes 2 and 3). 3 point belt (See Notes 2 and 3).	No requirement 3 point belt or lap belt (See Notes 3 and 8).	No requirement 3 point belt or a lap belt on all seats (See Note 3).
2. Motor Ambulances and Motor Caravans irrespective of design gross weight. From 1 October 1988 to 31 March 1997. From 1 April 1997.	3 point belt (See Notes 2 and 3). 3 point belt (See Notes 2 and 3).	3 point belt or lap belt (See Notes 3 and 8). 3 point belt or lap belt (See Notes 3 and 8).	No requirement 3 point belt or lap belt on all designated seats. (See Notes 3 and 7).

NOTE: "EFFECTIVE DATE"

In the case of an Amateur Built vehicle:-

- with an integral chassis-body - the date of manufacture of the chassis-body.
- having a separate chassis - the date of manufacture of the body or chassis whichever is the earlier.

In any other case

- The date of manufacture of the vehicle.

NB: The notes referred to above are contained in Annex 3.

5 Seat Belts - Obligatory Requirements

Annex 2b

Three Wheeled Vehicles without a Body (see note 9)

Front		Rear	
Driver's saddle seat position (See Note 10)	Any conventional seating position	Saddle seat position (see note 10 & 11)	Other rear seats
Nil	3 point belt or lap belt (see notes 3 & 8)	Nil	3 point belt or lap belt on all seats (see note 3)

NB: The notes referred to above are contained in Annex 3.

NOTE 1: The “specified front passenger seat” requiring a seat belt is the seat which is,

- foremost in the vehicle, and
- furthest from the driver’s seat

unless there is a fixed partition separating the passenger seat from a space in front of it which is alongside the driver’s seat, eg certain types of taxis, buses etc.

In the case of a vehicle having a central driving position and having passenger seats symmetrically positioned in relation to the driver’s seat, one passenger seat must be nominated as the “specified seat”.

NOTE 2: ‘3 point belt’ means a seat belt which,

- i. restrains the upper and lower parts of the torso
- ii. includes a lap belt
- iii. is anchored at not less than three points, and
- iv. is designed for use by an adult.

NOTE 3: Acceptable alternatives to any of the seat belt types listed are

- an adult harness belt comprising a lap belt and shoulder straps
- a passive 3 point seat belt.

NOTE 4: Outboard seats are seats closest to the vehicle sides.

NOTE 5: Rear facing or side facing seats are not required to be fitted with seat belts.

NOTE 6: Occasional seats that fold when not in use are not required to be fitted with seat belts.

A front centre seat on which the backrest folds down to become a driver/passenger armrest is not considered to be an occasional seat and should meet the required criteria.

NOTE 7: In respect of Motor Ambulances, Motor Caravans and Hearses; only seats in the area to the rear of the driver’s seated position intended for use when the vehicle is travelling on a road are required to be fitted with seat belts.

NOTE 8: A three point belt is required where, due to the seat position in relation to the windscreen, an upper anchorage is required (see Item 1, Note 1 of Procedure and Standards).

NOTE 9: “Body” means a structure comprising of one or more panels, with or without a roof, that encloses the passenger compartment.

NOTE 10: “saddle seat position” means a vehicle the seating arrangements of which include saddle type seats which are straddled by the driver and any pillion passenger seated upon the same longitudinal plane as the driver and immediately behind them.

NOTE 11: Only applies to seats immediately behind a driver’s “saddle seat” along the same longitudinal plane.

Interior Fittings 6

Application	Procedure and Standards	Reasons for Failure
<p>All vehicles except</p> <p>a. Goods vehicles</p> <p>b. Armoured vehicles where the requirements of this section only, shall not apply where it can be demonstrated that it is impossible to comply due to their special purpose.</p> <p>NOTE: Where necessary it is the responsibility of the applicant to prove why it is impossible to comply.</p> <p>c. Motor Caravans, Motor Ambulances and Hearses where the requirements of this section shall only apply to an area that is within the Head Impact Zone of a "designated seating position".</p> <p>NOTE: "Head Impact Zone" is the area contactable by a spherical head 165mm in diameter, the top of which is adjustable between 736mm and 840mm above the seat reference point (seat reference point is as shown in section 5, annex 4) measured with the seat in its fixed/rearmost position, and in the case of an adjustable seat, is 127mm forward of this position in either case with the seat in its lowest position.</p> <p style="text-align: right;">Cont'd ▼</p>	<p>The vehicle interior surfaces (other than the surface of a window) shall not include any fittings (eg controls, instruments, sun visors etc) or design features which have any dangerous roughness or "sharp edges" due to their exterior shape or design likely to be contacted by the occupants.</p> <p>ie. in an area (the specified zone) measured with the seat in the rearmost/lowest position</p> <ul style="list-style-type: none"> ▪ where the rearmost seat is forward facing; more than 150mm forward of the front of the seat backrest (measured where the backrest meets the cushion) ▪ where the rearmost seat is side or centre facing; more than 150mm forward of the seat centre line ▪ where the rearmost seat is rear facing; forward of the rearmost part of the seat backrest (measured where the backrest meets the cushion) and in either case 150mm above the top of the front seat cushion (measured at the lowest point) <p>with the exception of the windscreen side pillars (but not items moulded onto or secured to them which are not a functional part of the side pillow) and the area</p> <ul style="list-style-type: none"> ▪ forward of the steering control ▪ of the instrument panel between the steering control and the nearest side wall <p>as defined in the annex to this section.</p> <p>1. Visually check (where necessary using measuring equipment) the interior fittings and design features in the "specified zone" which can be contacted by a 165mm dia sphere for dangerous roughness or sharp edges.</p> <p>"Sharp edge" means an edge of a rigid material having a radius of curvature of less than 2.5mm,</p> <p style="text-align: right;">Cont'd ▼</p>	<p>1. An interior design feature or fitting</p> <p>a. has a rough or sharp edge or a projection of 3.2mm or more likely to cause injury ie having a radius of curvature less than 2.5mm</p> <p>b. has a projection of less than 3.2mm -</p> <p style="text-align: right;">Cont'd ▼</p>

6 Interior Fittings (cont'd)

Application	Procedure and Standards	Reasons for Failure
<p>d. vehicles which are</p> <ul style="list-style-type: none"> ▪ subject to the “Enhanced SVA Requirements” ▪ left hand drive ▪ a personal import ▪ a motor caravan ▪ an ambulance ▪ an armoured vehicle, or ▪ a hearse <p>where the requirements of item 1, 2, 3 and 4 (in relation to the instrument panel only) and item 5 shall not apply to the area forward of the driver or front passenger seating position where</p> <ul style="list-style-type: none"> - there is an air bag fitted for the forward protection of the seated occupant - that air bag was fitted at the time of manufacture. <p>e. Disabled Person’s vehicles</p> <ul style="list-style-type: none"> ▪ where the requirements of items 1 and 5 shall not apply to any switches, controls or equipment associated with those switches and controls designed for the use of a person with a disability providing any edges are blunted (see item 2), and <p style="text-align: right;">Cont'd ▼</p>	<p>except in the case of a projection from a panel which is less than 3.2mm. In this case the minimum radius of curvature shall not apply provided that the height of the projection is not more than half its width and its edges are blunted.</p> <p>NOTE 1: See Application column item “e” for Disabled Person’s vehicle exemptions.</p> <p>NOTE 2: This criteria does not apply to a gap not exceeding 20mm or to a feature on a control provided to improve grip eg “knurling” which are required to meet the criteria of items 3 & 4.</p> <p>NOTE 3: The requirements of this item do not apply to the control pedals.</p> <p>NOTE 4: Items not normally employed for the specific purpose by a major manufacturer eg a temporary fixing or covering, should not be considered acceptable. Materials, methods and application used in rectification may be accepted if they are permanent, durable and are of a kind which would normally be used by a major manufacturer.</p> <p>NOTE 5: In respect of items where the application of light pressure reduces the degree of projection to less than 3.2mm (eg speedo milage trip button) and when depressed the height of the projection is not more than half its width, it will be sufficient for any contactable edge to be blunted.</p> <p>“Light pressure” is pressure of not more than that required to compress a component of 50 shore A; i.e. a non rigid material.</p> <p style="text-align: right;">Cont'd ▼</p>	<ul style="list-style-type: none"> ▪ the height of which is more than half its width having a radius of curvature of less than 2.5mm ▪ the height of which is not more than half its width the edges of which are not blunted. <p style="text-align: right;">Cont'd ▼</p>

Interior Fittings (cont'd) 6

Application	Procedure and Standards	Reasons for Failure
<ul style="list-style-type: none"> ▪ where the requirements of item 7 shall not apply to any seat designated for a person with a disability. <p>Interior/Exterior Assessment</p> <p>Where a vehicle is not fitted with a facility to attach a hood/roof the interior/exterior boundary should be taken to be the mid point between interior and exterior on for example the windscreen pillar, top edge of body side and top edge of door. This is a subjective judgement to be made by the examiner. The interior is the passenger compartment including any luggage space within the same compartment. Other areas of the vehicle are considered to be "exterior" including open "luggage areas". Where the vehicle has a detachable (or fold back) hood/roof, the interior shall be taken to be the area covered by the hood/roof.</p>	<ol style="list-style-type: none"> 2. Check, on a disabled person's vehicle, that all switches and controls and equipment associated with those switches and controls, in each case that are designed for the use of a disabled person, that all edges contactable with a 165mm dia. sphere are blunted. 3. Check all controls, that any surface feature provided to improve grip (e.g. knurling) is blunted. 4. Check the edges of all gaps of not more than 20mm (i.e. grills, holes, recesses etc.) and any control feature mounted on a heating or ventilation grill element area, which in either case can be contacted by a 165mm dia sphere are blunted. <p>NOTE: A gap is measured between the contact points of a 165mm sphere bridging the gap.</p> <ol style="list-style-type: none"> 5. Check all switches, control knobs etc which <ul style="list-style-type: none"> ▪ are within the "specified area", and ▪ can be contacted by a 165mm dia. sphere, : and ▪ protrude from the instrument panel by more than 9.5mm, are likely to retract or detach when subject to an impact of 40kgf (88lbf) <p>NOTE 1: Protrusion of the component from the instrument panel is measured using equipment consisting of a 165mm dia. headform in which there is a sliding piston. Displacement of the piston is used to gauge the amount of protrusion. If other controls prevent the testing of a control by this method the examiner should make an assessment of the degree of protrusion likely to be measured. In cases where doubt remains the examiner may require the obstructing control to be removed to complete the assessment.</p> <p style="text-align: right;">Cont'd ▼</p>	<ol style="list-style-type: none"> 2. An edge of a switch or control or associated equipment not blunted. 3. A control surface feature not blunted. 4. An edge not blunted. <ol style="list-style-type: none"> 5. A switch, control knob or similar device mounted on the instrument panel is not likely to retract or detach during impact. <p style="text-align: right;">Cont'd ▼</p>

6 Interior Fittings (cont'd)

Application	Procedure and Standards	Reasons for Failure
	<p>NOTE 2: See Application column for exempted vehicles.</p> <p>6. Check the instrument panel lower edge (where positioned within the specified zone) is rounded to a radius of not less than 19mm (5mm if covered with a non-rigid material).</p> <p>NOTE 1: A "non-rigid material" is a material which has a hardness of less than 50 shore A. For the purposes of this examination it will be deemed to be a material which is capable of depression under thumb pressure and when deformed retains a degree of protection against contact with any structure which it is covering and when released returns to its original form.</p> <p>NOTE 2: The "instrument panel" should be taken to be "The area to the front of the passenger compartment, bounded by the vehicle sides and extending from the upper edge of the forward bulkhead interior panelling (dash panel) down to the lowest edge of the panelling (including "dash panel", "glove box" etc).</p> <p>7. On a seat behind which there is a designated seating position, check the rearward and upward facing parts of the seat frame within the head impact zone</p> <ul style="list-style-type: none"> ▪ are covered with a non-rigid material, and ▪ have a radius of curvature of not less than 5mm. <p>NOTE 1: It will be acceptable as an alternative if the applicant can show that the vehicle equipment complies with the head impact test of Directive 74/60 (or that the components are identical to those fitted to a European Approved vehicle of the same specification).</p>	<p>6. An instrument panel lower edge has a radius of curvature of less than 19mm (less than 5mm if covered with a non-rigid material).</p> <p>7. A seat frame rearward facing or upward facing part</p> <ul style="list-style-type: none"> ▪ not covered with a non-rigid material ▪ has a radius of curvature less than 5mm.

Cont'd ▼

Cont'd ▼

Interior Fittings (cont'd) 6

Application	Procedure and Standards	Reasons for Failure
	<p>NOTE 2: "Designated seating position" means a position where there is a seat designated for normal use while the vehicle is travelling on the road.</p> <p>8. Check the hand brake control in the fully released position (if in the specified area) and the gear-lever in all forward gear positions, that any surface contactable with a 165mm dia sphere does not have a radius of curvature of less than 3.2mm.</p> <p>NOTE: The requirements of item 5 relating to the hand brake control do not apply if</p> <ul style="list-style-type: none"> ▪ the hand brake control is mounted on or under the instrument panel of the vehicle, and ▪ when it is in the released position, there is no possibility of the occupants of the vehicle contacting it in the event of a frontal impact to the vehicle. <p>9. Check shelves and other similar items fitted below the level of the highest part of the instrument panel</p> <ol style="list-style-type: none"> a. have no protruding edges on their supports b. that all parts facing into the vehicle have a surface <ul style="list-style-type: none"> ▪ at least 25mm high, and ▪ with edges rounded to a radius of curvature of not less than 3.2mm, and ▪ covered with a non-rigid material. <p>10.</p> <ol style="list-style-type: none"> a. Examine the inner surface of the roof structure and any attached components (eg. grab handles, lights, sun visors) in either case above and forward of the occupant positions, which <p style="text-align: right;">Cont'd ▼</p>	<p>8.</p> <ol style="list-style-type: none"> a. A handbrake control has a 'contactable surface' having a radius of curvature of less than 3.2mm. b. A gear lever when in a forward gear position has a 'contactable surface' having a radius of curvature of less than 3.2mm. <p>9. A shelf or other similar fitting has</p> <ol style="list-style-type: none"> a. a support having a protruding edge b. a part facing into the vehicle having <ul style="list-style-type: none"> ▪ a surface less than 25mm high ▪ an edge with a radius of curvature of less than 3.2mm ▪ no covering of non-rigid material. <p>10.</p> <ol style="list-style-type: none"> a. The roof <ul style="list-style-type: none"> ▪ has a projecting part the width of which is less than the length of the projection <p style="text-align: right;">Cont'd ▼</p>

6 Interior Fittings (cont'd)

Application	Procedure and Standards	Reasons for Failure
	<p>can be contacted with a 165mm dia sphere and check that on any projecting part made of a rigid material</p> <ul style="list-style-type: none"> ▪ the width is not less than the length of the projection ▪ if part of the roof structure, contactable edges have a radius of curvature of not less than 5mm ▪ if an attached component, contactable edges have a radius of curvature of not less than 3.2mm. <p>b. Check all roof sticks or ribs made of a rigid material (with the exception of the header rail of glazed surfaces and door frames) do not project downwards by more than 19mm.</p> <p>NOTE 1: The requirements of item 10 also apply to an opening (sun) roof including its opening and operating devices when it is in the closed position.</p> <p>NOTE 2: The requirements of item 10 DO NOT apply to parts covered with a non-rigid material or to the hood frames of convertible vehicles.</p>	<ul style="list-style-type: none"> ▪ structure has an edge having a radius of curvator of less than 5mm ▪ component has an edge having a radius of curvator of less that 3.2mm. <p>b. A roof stick or rib made of a rigid material projects downwards more than 19mm.</p>

The front area of the “specified zone” between its base line (150mm above the seat) and a horizontal plane at the level of the lower edge of the instrument panel if this is higher, is subject to the criteria of this section.

Components in this area are subject to the radius requirements if contactable by the forward projection of a sphere having a diameter of 165mm. Part of the sphere may be placed below the base line, or above the horizontal level with the lower edge of the instrument panel to assess contactability, but only where the component is in the above defined area is compliance with the radius requirements required. (see diagram)

The sphere should not be used to assess contactable surfaces/edges that are above the lower edge of the Instrument panel **and** which are behind the panel.

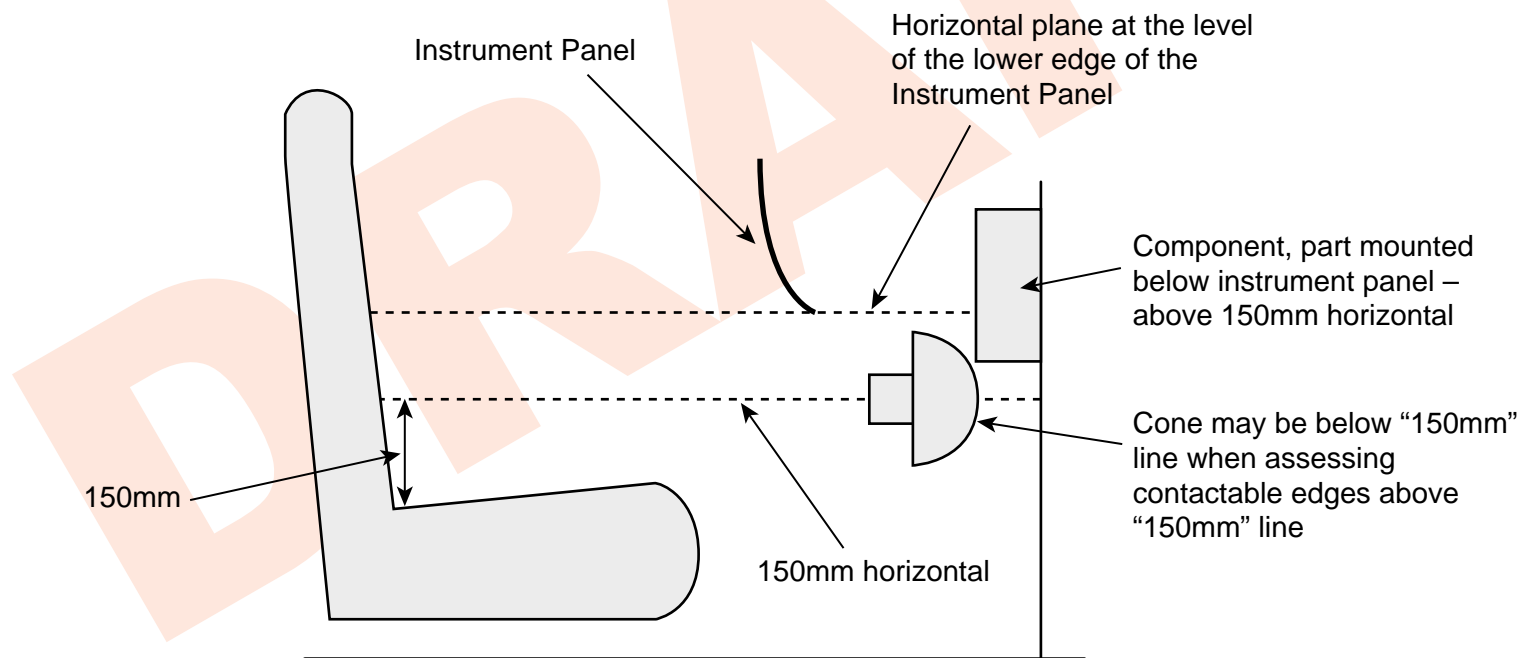

8 Glazing (cont'd)

Application	Procedure and Standards	Reasons for Failure
	<p>NOTE 2: A Side-screen which may be mounted in a structure, and which in either case is hinged to allow entry/exit and which is permanently secured to the vehicle (ie is not detachable) is considered to be a door and, other than the glazing material, is subject to the requirements of section 12.</p> <p>3.</p> <p>a. Check all WINDSCREENS and OTHER WINDOWS WHOLLY OR PARTLY ON EITHER SIDE OF THE DRIVER'S SEAT (other than side screens) are made of safety glass to a recognised standard or an equivalent standard.</p> <p>b. Check all OTHER WINDOWS (including sun-roofs/removable glass roof panels) and SIDE SCREENS are made of safety glass to a recognised standard or an equivalent standard or safety glazing.</p> <p>NOTE 1: "safety glass" means glass so constructed or treated that if fractured it does not fly into fragments likely to cause severe cuts.</p> <p>NOTE 2: safety glass must conform to one of the following European standards and bear the relevant marking applied by the manufacturer</p> <ul style="list-style-type: none"> ▪ British Standard: BS857 or BS857/2 BS5282 BSAU178 ▪ ECE Regulation 43 eg E11 43R-002439 ▪ EEC Directive 92/22 eg e11 <p style="text-align: right;">Cont'd ▼</p>	<p>3.</p> <p>a. A windscreen or other window wholly or partly on either side of the driver's seat not made of safety glass to a recognised standard or an equivalent standard.</p> <p>b. A window not made of safety glass to a recognised standard or an equivalent standard or safety glazing.</p> <p style="text-align: right;">Cont'd ▼</p>

Application	Procedure and Standards	Reasons for Failure
	<p>or must conform to any national or international standard equivalent to those listed above or to one of the standards listed in the Annex on Non-European standards and bear the relevant marking applied by the manufacturer.</p> <p>NOTE 3: "safety glazing" means material (other than glass) which is so constructed or treated that if fractured it does not fly into fragments likely to cause severe cuts. There is no marking requirement for safety glazing.</p> <p>4. Check the opacity of all windscreens/windows allows a visual transmission for light of not less than 70% (in the case of an armoured vehicle 60%).</p> <p>NOTE 1: In the case of an armoured vehicle the applicant may be required to provide evidence of compliance.</p> <p>NOTE 2: This requirement does not apply to windows every part of which is behind the driver providing the vehicle is fitted with a Nearside Exterior Mirror which meets the requirements of Item 10 of this manual.</p> <p>NOTE 3: A greater opacity is permitted in the area of the windscreen below the "windscreen horizontal plane" (as defined in the Annex to Section 2 of this manual) and the area considered to be above the normal field of view.</p>	<p>4. A windscreen, window or side screen opacity greater than the maximum level permitted.</p>

Lighting/Signalling (obligatory) 9.1

Application	Procedure and Standards	Reasons for Failure
<p>All vehicles except</p> <ol style="list-style-type: none"> Goods vehicles Motor Ambulances, Motor Caravans, Hearses and Armoured vehicles only where the special purpose makes it impossible to fully comply with the positional requirements and providing all other requirements are met. <p>NOTE: Where necessary it is the responsibility of the applicant to prove why it is impossible to comply.</p> <p>This inspection includes</p> <ul style="list-style-type: none"> headlamps (but not “dim-dip” or “headlamp levelling” devices) front position lamps rear position lamps stop lamps rear fog lamps direction indicator/hazard warning lamps rear registration plate lamps, and reflectors <p>which must be fitted.</p> <p>The “Date of first use” used to determine the criteria applicable is</p> <ul style="list-style-type: none"> for an “Import” vehicle; the date of manufacture <p style="text-align: right;">Cont'd ▼</p>	<ol style="list-style-type: none"> Check the vehicle is not fitted with a lamp or retro reflective material capable of showing: <ol style="list-style-type: none"> a red light to the front, or a light other than red “to the rear”, except <ul style="list-style-type: none"> amber light from a direction indicator white light from a work lamp, reversing lamp, interior lamp, or a registration plate lamp yellow light from a registration plate. <p>NOTE: “to the rear” is as defined in Annex 6</p> <ol style="list-style-type: none"> Check all obligatory lamps and, as appropriate, reflectors for <ul style="list-style-type: none"> the correct number being fitted (see Annex 7) operation/completeness/security approximate position (see Notes 1, 2, 6 & 8) colour intensity (brightness) (see Notes 3 & 4) angles of visibility (see Notes 7 & 8) <p>Details of the individual requirements for obligatory lamps are shown in Annex 1 to this section.</p> <p>NOTE 1: Lamp/reflector lateral position is measured from the extreme outer edge of the vehicle (disregarding tyres, mirrors, lamps and reflectors) to the edge of the illuminated area (or reflective surface on a reflector) nearest that side of the vehicle. Lamp/reflector vertical position is measured from the ground;</p> <p>in the case of the minimum height to the lower edge of the illuminated area (reflective surface on a reflector) see*below</p> <p style="text-align: right;">Cont'd ▼</p>	<ol style="list-style-type: none"> A lamp or retro reflective material capable of showing <ul style="list-style-type: none"> a red light to the front, or a light other than red to the rear unless it is a listed exception. <ol style="list-style-type: none"> An obligatory lamp or, where appropriate, reflector <ul style="list-style-type: none"> missing, insecure or incomplete inoperative with a lens missing/incomplete incorrectly positioned not of the correct colour switch missing, faulty or insecure except in the case of a headlamp, not of a similar brightness when compared with a lamp bearing an appropriate approval mark as given in Annex 1 in the case of a headlamp, insufficient light is emitted either on dip or main beam to illuminate the road in front of the vehicle. does not meet the required angles of visibility. <p style="text-align: right;">Cont'd ▼</p>

9.1 Lighting/Signalling (obligatory) cont'd

Application	Procedure and Standards	Reasons for Failure
<ul style="list-style-type: none"> ▪ for any other vehicle; the date on which the vehicle is tested. <p style="text-align: center;">_____ “_____”</p> <p>NOTE: A lamp shall not be treated as a lamp if it is painted over, or masked (permanently) or is not provided with a system of wiring to which it can be readily connected,</p> <ul style="list-style-type: none"> ▪ removal of the bulb, ▪ removal of the switch, ▪ removal of the bulb holder, (if capable of assembly without workshop tools) ▪ disconnection of a socket ▪ silicone or tape in/over a plug/socket, ▪ a combination of the above, or ▪ any modification that can be reverted without the need for workshop equipment; <p>will not eliminate the lamp from the requirements of this section.</p>	<p>in the case of the maximum height to the top edge of the illuminated area (reflective surface on a reflector)</p> <p>*In the case of a Dipped Beam headlamp the minimum height is measured to the apparent trace of the beam cut-off on the lens.</p> <p>NOTE 2: Rear Fog Lamp separation distance must be measured between the “illuminating surface” of each lamp. “Illuminating Surface” should be taken to be the area of the “reflector” to the rear of the bulbs.</p> <p>Where lamps are mounted in a common housing and are “E” marked, the separation criteria should be assumed to be met.</p> <p>NOTE 3: The brightness of lamps bearing an appropriate approval mark as given in Annex 1 defines the acceptable standard. Lamps not bearing such a mark should emit light of similar brightness.</p> <p>The maximum permitted intensity of an “e” or “E” marked high level stop lamp, being 80 candelas is insufficient to meet the requirements as a rear fog lamp which requires a minimum intensity of 150 candelas.</p> <p>NOTE 4: Headlamps should not be compared for brightness, but should emit sufficient light to illuminate the road in front of the vehicle on both main and dipped beams.</p> <p>NOTE 5: Lamp security must be assessed taking account of the method of attachment intended by the manufacturer. Double-sided tape is to be considered acceptable only in situations where it is the manufacturers intended method.</p> <p>NOTE 6: Lamp position achieved by the external masking of part of the illuminated area is</p>	<p>b. A stop lamp</p> <ul style="list-style-type: none"> ▪ does not show a steady red light when the service brake is applied ▪ remains on when the brake is released.

Cont'd ▼

Cont'd ▼

Lighting/Signalling (obligatory) cont'd 9.1

Application	Procedure and Standards	Reasons for Failure
	<p>not considered to prevent the lamp from being readily put to use and therefore unacceptable.</p> <p>NOTE 7: Side repeater indicators mounted on a "cycle wing" that move with steering movement, are required to meet the angles of visibility requirement with the steering in the straight ahead position only. Where fitted to a "Lotus seven" style vehicle (having a proportionally decreasing body width towards the front) a side repeater does not need to meet the angles of visibility requirements providing it is clearly visible to other road users to the rear of the nearside and offside of the vehicle as appropriate.</p> <p>NOTE 8: The positional and angles of visibility requirements are required to be met when all doors, bonnet, boot lid etc. are in the closed position (and not when open).</p> <p>3. Check all front and rear position lamps and registration plate lamps fitted can be switched on and off by operating one switch.</p> <p>4. Check</p> <p>a. each dipped beam headlamp system where the light source is produced by 'gas discharge' either</p> <ul style="list-style-type: none"> ▪ is accompanied by evidence of compliance with the technical requirements of UN ECE Regulations 98, 99 and in respect of those lamps the installation requirements of regulation 48.01, or ▪ incorporates the following equivalent characteristics <ul style="list-style-type: none"> - is "E" or "e" marked, - dipped beam remains on when mainbeam is on, <p style="text-align: right;">Cont'd ▼</p>	<p>3. The front and rear position lamps and registration plate lamps are not controlled by one switch.</p> <p>4.</p> <p>a. A 'gas discharge' headlamp system</p> <ul style="list-style-type: none"> ▪ not accompanied by evidence of compliance with the technical requirements of UN ECE Regulations 98, 99 and the installation requirements of regulation 48.01 and ▪ does not have the equivalent characteristics to that of an approved lamp. <p style="text-align: right;">Cont'd ▼</p>

9.1 Lighting/Signalling (obligatory) cont'd

Application	Procedure and Standards	Reasons for Failure
	<ul style="list-style-type: none"> - is fitted with a wash system, - is fitted with an automatic headlamp self levelling system. <p>b. where two main beam or dipped beam headlamps are required to be fitted, their operation and that they form a matched pair ie of the same shape as to be symmetrical to each other, colour, intensity and size</p> <p>c. not more than two dipped beam headlamps designed for a vehicle travelling on the L/H side of the road are fitted.</p> <p>5. Check the rear fog lamp is</p> <ul style="list-style-type: none"> ▪ fitted with an operational "tell-tale" lamp visible from the driving position ▪ not operated by a brake control. ▪ fitted such that the reflector is facing squarely to the rear <p>NOTE: "Reasonable movement" by the driver when in the driving position or movement of the driving controls to gain sight of the "tell-tale" is permitted.</p> <p>6.</p> <p>a. Check the nearside and offside direction indicators are capable of flashing constantly at a rate of between 60 and 120 flashes per minute (with all mandatory indicators working).</p> <p>NOTE: In cases where the rate is below the requirement, this check may be carried out with the engine running.</p> <p>b. Check the presence of a direction indicator "tell-tale" warning device.</p>	<p>b. A headlamp</p> <ul style="list-style-type: none"> ▪ not forming part of a matched pair ▪ main beam cannot be switched off by operating one switch which at the same time leaves a dipped beam <p>c. More than two dipped beam headlamps which dip to the left.</p> <p>5. A rear fog lamp</p> <ul style="list-style-type: none"> ▪ has no "tell-tale" light fitted ▪ has an inoperative "tell-tale" light, so that it cannot be identified ▪ has a "tell-tale" light that cannot be seen from the driving position ▪ operated by a brake control. ▪ fitted such that the reflector is not facing squarely to the rear. <p>6. A direction indicator</p> <ul style="list-style-type: none"> ▪ is not capable of flashing at a constant rate between 60 and 120 times per minute ▪ "tell-tale" warning device missing or inoperative.

Cont'd ▼

Cont'd ▼

Lighting/Signalling (obligatory) cont'd 9.1

Application	Procedure and Standards	Reasons for Failure
	<p>NOTE: A “tell-tale” may be audible or visual. It is not required if one or more direction indicators on each side of the vehicle can be seen by the driver from the driver’s seat.</p> <p>7. Check the hazard warning device</p> <ol style="list-style-type: none"> operates with the ignition switched both on and off operates all the direction indicators causing them to flash simultaneously has an operational “tell-tale” warning device. <p>NOTE: The “tell-tale” device must be in the form of a flashing light, which may be the same lamp as the direction indicator “tell-tale”.</p> <p>8. Check that no lamp or reflector can be moved by swivelling, deflecting or otherwise while the vehicle is in motion.</p> <p>NOTE 1: This requirement does not apply to the following</p> <ul style="list-style-type: none"> ▪ any lamp or reflector which by design can be deflected to the side by the movement of the front wheel or wheels of the vehicle when turned for the purpose of steering the vehicle ▪ a headlamp for adjustment or dipping of the beam or which can be retracted or concealed ▪ a work lamp. <p>NOTE 2: A worklamp is a lamp used to illuminate a working area or the scene of an accident, breakdown or roadworks in the vicinity of the vehicle to which it is fitted.</p> <p>9. Check (other than in the case of an emergency vehicle, eg ambulance) that the vehicle is not fitted with any beacon or external warning lamp that is blue in colour.</p> <p style="text-align: right;">Cont'd ▼</p>	<p>7. A hazard warning device</p> <ul style="list-style-type: none"> ▪ does not operate with the “ignition switch” in both the on and off position ▪ does not cause all the direction indicators to flash simultaneously ▪ “tell-tale” light device not fitted or inoperative. <p>8. A lamp (other than a headlamp for the defined purposes, or work lamp) capable of being moved by swivelling, deflecting or otherwise while the vehicle is in motion.</p> <p>9. The vehicle is fitted with a beacon or external warning lamp that is blue in colour.</p> <p style="text-align: right;">Cont'd ▼</p>

9.1 Lighting/Signalling (obligatory) cont'd

Application	Procedure and Standards	Reasons for Failure
	<p>10. Check each</p> <ul style="list-style-type: none"> ▪ front and rear position lamp ▪ front and rear direction indicator ▪ rear retro reflector <p>has part of the apparent surface visible when viewed from directly in front or behind as appropriate, when every door, tailgate, boot lid or other movable part is in the fixed open position.</p> <p>NOTE 1: “fixed open position” means any static open position in which the component will remain (with or without a fixed stay).</p> <p>NOTE 2: Where an obligatory reflector is obstructed, it is acceptable if a notice (of a permanent nature) is displayed in the vehicle that shall inform the user that in certain positions of the particular movable component, other road users shall be warned of the presence of the vehicle on the road for example by use of a warning triangle.</p>	<p>10. A lamp or reflector not visible when a part of the vehicle is in the fixed open position.</p>

Annex 1

Requirements for Obligatory Lamps 9.1

TYPE/APPLICATION	NUMBER	APPLICATION DATE	COLOUR	POSITION			ANGLES OF VISIBILITY	APPROVAL MARK "E" or "e" Identity Symbol or BS Mark
				MAX DISTANCE FROM SIDE (mm)	MAX HEIGHT (mm)	MIN HEIGHT (mm)		
Dipped Beam Headlamps Vehicles with 4 or more wheels, or vehicles with 3 wheels and ULW over 400kg or overall width over 1300mm	Two	All Vehicles	White or Yellow	400	1200	500 (see P & S Item 2, Note 1)	No Requirement	C (S - Sealed Beam H - Halogen) with → or ↔ or BS AU40
Main Beam Headlamps Vehicles with 4 or more wheels, or vehicles with 3 wheels and ULW over 400kg or overall width over 1300mm	Two	All Vehicles	White or Yellow	No Requirement	No Requirement	No Requirement	No Requirement	R (S - Sealed Beam H - Halogen) or BS AU40
Front Position Lamps	Two	All Vehicles	White; Yellow if in Yellow Headlamp	400	1500 or if impracticable 2100 (See Note)	No Requirement	a. Horizontal:- 80° outwards - 45° inwards. b. Vertical i. < 750mm above the ground - 15° above and 5° below horizontal. ii. otherwise 15° above and below horizontal.	A
Rear Position Lamps	Two	All Vehicles	Red	400 (Min separation 500 unless vehicle width is less than 1400, where Min separation 400)	1500 or if impracticable 2100 (See Note)	350	a. Horizontal:- 80° outwards - 45° inwards. b. Vertical i. < 1500mm above the ground - 15° above and 10° below horizontal. ii. < 750mm above the ground - 15° above and 5° below horizontal. iii. otherwise 15° above and below horizontal.	R
Rear Registration Plate Lamps	Such that adequate illumination is provided	All vehicles requiring a registration plate.	White	Such that the lamp or lamps are capable of adequately illuminating the rear registration plate.				

Note: It is to be considered practicable to comply with the lesser height requirement where there is body structure below that height.

Cont'd ▼

9.1 Requirements for Obligatory Lamps (cont'd)

Annex 1

TYPE/APPLICATION	NUMBER	APPLICATION DATE	COLOUR	POSITION			ANGLES OF VISIBILITY	APPROVAL MARK "E" or "e" Identity Symbol or BS Mark
				MAX DISTANCE FROM SIDE (mm)	MAX HEIGHT (mm)	MIN HEIGHT (mm)		
Stop Lamps	Two	All Vehicles	Red	One on each side of longitudinal axis (Min separation 400)	1500 or if impracticable 2100 (See Note Page 1)	350	a. Horizontal i. 45° inwards and outwards b. Vertical i. as rear position lamps.	S1 or S2
Rear Fog Lamp	One	All Vehicles	Red	On centre line or to offside of vehicle (Min separation distance from stop lamp 100)	1000	250	a. Horizontal i. 25° inwards and outwards; if two lamps are fitted it is sufficient if one lamp (not necessarily the same lamp) - is visible throughout the range b. Vertical i. 5° above and below horizontal.	B or F
Direction Indicators	On each side Front - One Rear - One Side Repeater - One	All Vehicles	Amber	400 (see Note) (Min separation 500 unless vehicle width is less than 1400, where Min separation 400)	1500 or if impracticable 2300 (See Note Page 1)	350	a. Horizontal i. 80° outwards - 45° inwards. ii. (SIDE REPEATER) To the rear between 5° and 60° outboard. b. Vertical i. < 750mm above the ground 15° above and 5° below horizontal. ii. Otherwise 15° above and below horizontal.	From 1/4/86 Front 1, 1a, 1b or 11 Front - side 3 or 4 Side Repeater 5 Rear 2a, 2b or 12
Rear Retro Reflectors	Two	All Vehicles	Red	400 (Min separation 600 unless vehicle width less than 1300, where Min separation 400)	900 or if impracticable 1200 (See Note Page 1)	250	a. Horizontal i. 30° inwards and outwards. b. Vertical i. < 750mm above the ground 15° above and 5° below horizontal. ii. otherwise 15° above and below horizontal.	1 or 1A

NOTE: In the case of a rear direction indicator this dimension is increased to 480mm where: a) the vehicle is **not** of the category "Constructed by a manufacturer using parts from a registered vehicle" or "Amateur Built", and b) the lamp shares a common housing, ie is one of a 'cluster' of lamps.

Annex 6 Lighting/Signalling - Definition - "to the rear" 9.1

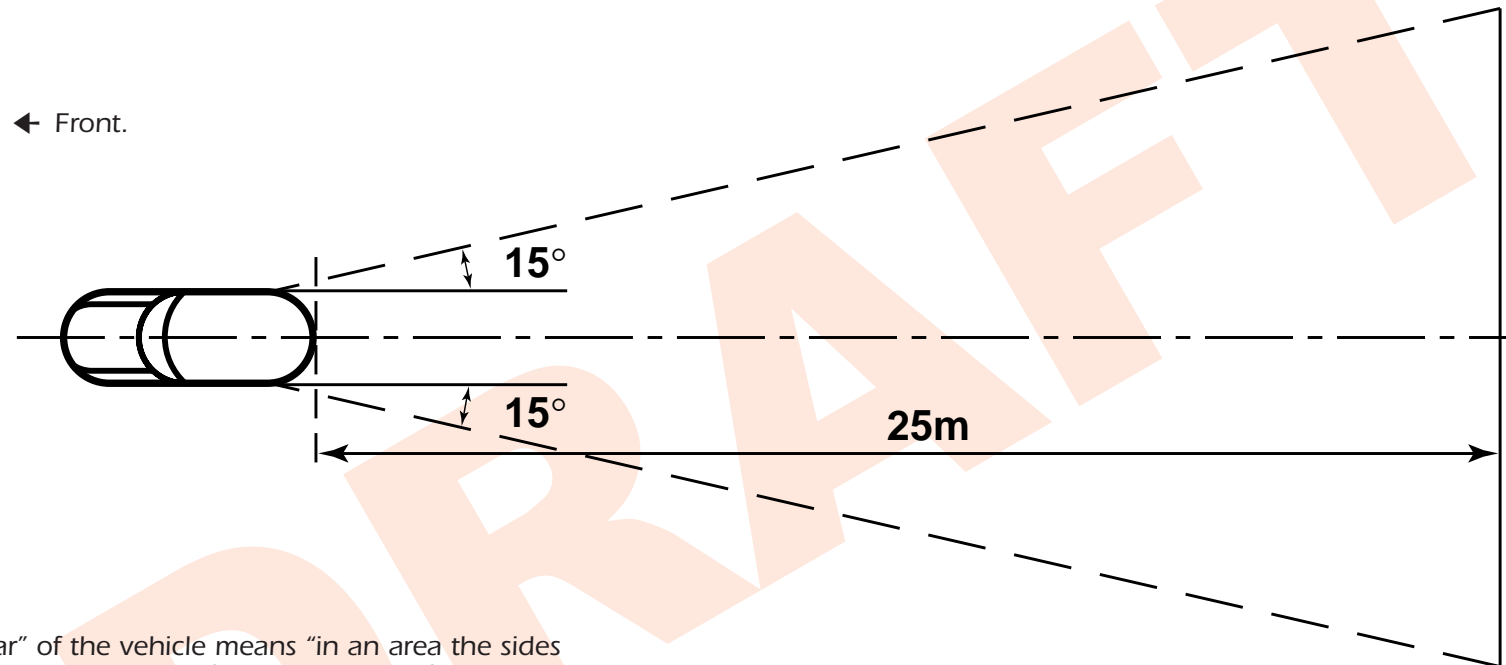

"To the rear" of the vehicle means "in an area the sides of which are at an angle of 15 degrees out from the extreme outer edge of the vehicle, (starting from the rear corner) and extending up to **25mtrs** from the rear of the vehicle (measured along the vehicle longitudinal).

NOTE: 15 degrees at 5m distance = 1330mm
15 degrees at 10m distance = 2670mm

No light other than a red light (with the exception of amber light from a direction indicator, white light from a work lamp, reversing lamp, or a registration plate lamp or yellow light from a registration plate lamp) is permitted to be visible in this area.

Annex 7 Lighting/Signalling - Lamps in Close Proximity 9.1

Two or more lamps (see "A" and "B" in diagram below) whether identical or not, having the same function and emitting light of the same colour are considered to be one lamp if the aggregate illuminated area of the lamps occupies 60% or more of the area of the smallest rectangle circumscribing those illuminated areas"

If the total of area "A" added to area "B" is 60% or more of the area of the rectangle drawn around the lamps, the lamps are considered to be one lamp

Smallest rectangle that can be drawn around the two areas "A" and "B"

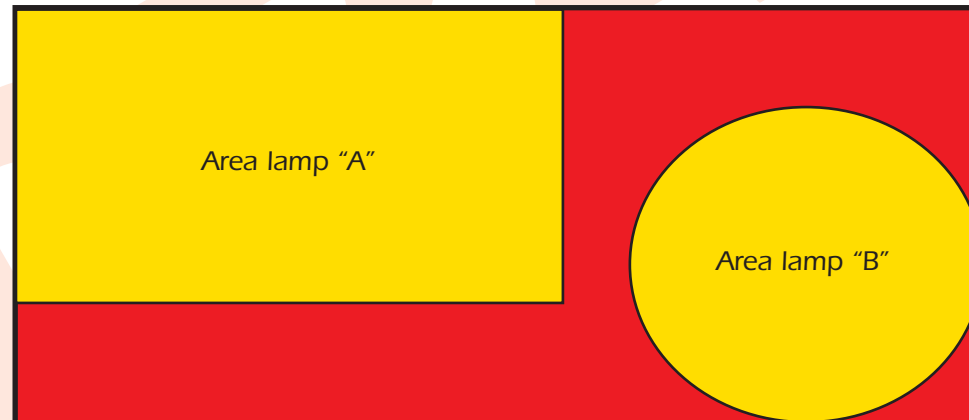

Lighting/Signalling (optional) 9.2

Application	Procedure and Standards	Reasons for Failure
<p>All vehicles except Goods vehicles.</p> <p>The “date of first use” used to determine the criteria applicable is</p> <ul style="list-style-type: none"> ▪ for an “Import” vehicle, the date of manufacture ▪ for any other vehicle, the date on which the vehicle is tested. <p style="text-align: center;">————— “ —————</p> <p>NOTE: A lamp shall not be treated as a lamp if it is painted over, or masked (permanently) or is not provided with a system of wiring to which it can be readily connected,</p> <ul style="list-style-type: none"> ▪ removal of the bulb, ▪ removal of the switch, ▪ removal of the bulb holder, (if capable of assembly without workshop tools) ▪ disconnection of a socket ▪ silicone or tape in/over a plug/socket, ▪ a combination of the above, or ▪ any modification that can be reverted without the need for workshop equipment; <p>will not eliminate the lamp from the requirements of this section.</p>	<ol style="list-style-type: none"> 1. Check the vehicle is not fitted with a lamp or retro reflective material capable of showing: <ol style="list-style-type: none"> a. a red light to the front, or b. a light other than red to the rear, except <ul style="list-style-type: none"> ▪ amber light from a direction indicator ▪ white light from a work lamp, reversing lamp, interior lamp, or a registration plate lamp ▪ yellow light from a registration plate. 2. Check optional lamps and as appropriate reflectors for <ul style="list-style-type: none"> ▪ number fitted ▪ colour. <p>Details of the individual requirements for optional lamps are shown in the Annex to this section.</p> 3. Check the operation and condition of all optional stop lamps, direction indicators and hazard warning lamps. 	<ol style="list-style-type: none"> 1. A lamp or retro reflective material capable of showing <ul style="list-style-type: none"> ▪ a red light to the front, or ▪ a light other than red to the rear unless it is a listed exception. 2. An optional lamp or where appropriate reflector <ul style="list-style-type: none"> ▪ fitted in addition to the maximum number permitted ▪ not of the correct colour. 3. An optional stop lamp, direction indicator or hazard warning lamp <ul style="list-style-type: none"> ▪ insecure/incomplete ▪ has a lens missing/incomplete ▪ inoperative.

Cont'd ▼

Cont'd ▼

Lighting/Signalling (optional) cont'd 9.2

Application	Procedure and Standards	Reasons for Failure
		<p>d. An optional rear fog lamp</p> <ul style="list-style-type: none"> i. fitted where the illuminating surface is not within a height of 250mm (min) and 1000mm (max) of the ground ii. does not provide an angle of visibility of <ul style="list-style-type: none"> ▪ horizontally: 25° inwards and outwards. If two lamps are fitted, it is sufficient if one lamp (not necessarily the same lamp) is visible throughout the range ▪ vertically: 5° above and below the horizontal. iii. not fitted with an operational "tell-tale". <p>e. An optional direction indicator</p> <ul style="list-style-type: none"> ▪ not operating in conjunction with the obligatory direction indicators. <p>f. A reversing lamp</p> <ul style="list-style-type: none"> ▪ not directed to the rear ▪ operated by a switch not in conjunction with the selection of reverse gear and which is not fitted with a "tell-tale" warning device. <p>g. A front fog lamp</p> <ul style="list-style-type: none"> ▪ capable of operation independently of the dipped beam lamps where the maximum distance from the side of the vehicle to the outer edge of the illuminated area is more than 400mm. ▪ where part of the illuminating surface is more than 1200mm above the ground. <p>h. An optional reflector which is triangular in shape.</p>

DRAFT

10 Mirrors (cont'd)

Application	Procedure and Standards	Reasons for Failure
	<p>3. Check the equivalent characteristics include</p> <ul style="list-style-type: none"> a. the reflective surface must be enclosed in a protective housing, and b. surfaces contactable by a sphere of, <ul style="list-style-type: none"> ▪ 165mm dia for an interior mirror ▪ 100mm dia for an exterior mirror must have a radius of curvature of not less than 2.5mm except fixing holes or recesses less than 12mm wide, which must be blunted, and c. in the case of exterior mirrors mounted on the nearside or offside of the vehicle, that they, <ul style="list-style-type: none"> ▪ are capable of rotating inwards towards the vehicle when a force of 10kg is applied horizontally at the extreme outer edge from both the front and the rear ▪ have an axis of rotation to be within 50mm of the vehicle surface to which they are mounted <p>NOTE: This criteria (item c) does not apply to a mirror</p> <ul style="list-style-type: none"> ▪ every part of which is at least 2m above the ground ▪ which does not protrude beyond the extreme outer edge of the vehicle (discounting the mirrors), and d. in the case of a four wheeled vehicle obligatory mirror only, a reflecting surface area sufficient to accommodate a rectangle, <ul style="list-style-type: none"> ▪ in the case of an interior mirror 40mm high x 80mm length ▪ in the case of an exterior mirror 40mm high x 70mm length and a line parallel to the height of the rectangle not less than 70mm in length. <p style="text-align: right;">Cont'd ▼</p>	<p>3. A mirror that is not European approved</p> <ul style="list-style-type: none"> a. has a reflective surface edge not enclosed in a protective housing b. has a sharp edge or protrusion likely to cause injury c. in the case of an exterior mirror, <ul style="list-style-type: none"> ▪ not capable of rotating inwards when a force of 10kg is applied ▪ not having an axis of rotation within 50mm of the mounting surface. d. has a reflecting surface too small to accommodate the prescribed dimensions. <p style="text-align: right;">Cont'd ▼</p>

Annex 3 Mirror Field of View - Alternative Test Procedure

Layout of Floor Markings

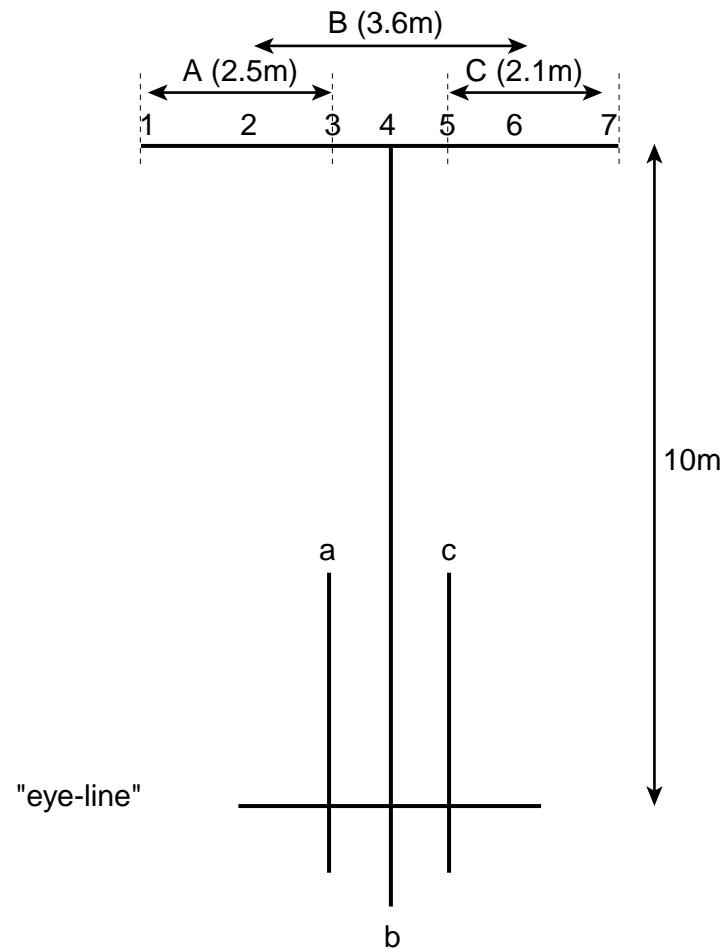

Position poles and "flags" (where required) as per the diagram adjacent and that on page 4

With a pole positioned vertically at the floor marking 3 in respect of the offside exterior mirror; 4 in respect of the interior mirror; and where required, (see note 3) 5 in respect of the nearside exterior mirror, mark poles 3, 4, and 5 to show the height of the upper edge of the corresponding mirror reflective surface (the "mirror dimension").

Using the chart shown on pages 2 and 3, by reference to the "mirror dimension" (column X) obtain the interior mirror lower marker height (column Y) and mark horizontal line on poles 2, 4 and 6 at the given height. Where required, (see note 3) obtain the nearside mirror lower marker height (column Z) and mark horizontal line on poles 5 and 7 at the given height.

In cases where the driver's seat is adjustable, position the seat in the rearmost position.

When seated in the driver's seat looking ahead and in a comfortable upright driving position, align the vehicle such that your eye position is vertically aligned with the transverse floor "eye-line" marking and with

- the offside extreme outer edge of the vehicle positioned along line 'a'; check that up to the height of the "mirror dimension" on pole 3 and the whole of the floor marking 1 to 3 is visible in the offside exterior mirror (see note 1 & 2);
- the longitudinal centre line of the vehicle positioned along line 'b'; check that the section of pole 4 between the upper ("mirror dimension") marker and the lower marker, and the whole of the horizontal line formed between poles 2, 4 and 6 is visible in the interior mirror (see notes 1, 2 & 3);
- (where required) the nearside extreme outer edge of the vehicle positioned along line 'c'; check that the section of pole 5 between the upper ("mirror dimension") marker and the lower marker, and the whole of the horizontal line formed between poles 5 and 7 is visible in the nearside exterior mirror (see notes 1, 2 & 3);

NOTE 1: While sitting in the driving position, facing forward, the respective field of view in each mirror should be obtainable by pivoting the eyes/head, without bodily movement.

NOTE 2: Obstruction by 'sundry' items in the case of an interior mirror of 15% and in the case of an exterior mirror 10% is permitted (see Procedure and Standards item 5).

NOTE 3: If an interior mirror does not provide the required field of view, a nearside exterior mirror meeting the appropriate field of view requirement must be fitted.

10 Mirror Field of View - Alternative Test Procedure Annex 3

NOTE 1: If the “mirror dimension” falls between the table increments of column “X” use the next highest entry.

NOTE 2: If the “mirror dimension” is outside the scope of this table refer to calculation on next page.

(Y) Interior Mirror Marker Lower Height (mm)	(X) Height To Top Of Lens (mm)	(Z) Nearside Mirror Marker Lower Height (mm)
1230	1500	713
1222	1490	708
1214	1480	703
1205	1470	698
1197	1460	694
1189	1450	689
1181	1440	684
1173	1430	679
1164	1420	675
1156	1410	670
1148	1400	665
1140	1390	660
1132	1380	656
1123	1370	651
1115	1360	646
1107	1350	641
1099	1340	637
1091	1330	632
1082	1320	627
1074	1310	622
1066	1300	618
1058	1290	613
1050	1280	608
1041	1270	603
1033	1260	599
1025	1250	594
1017	1240	589
1009	1230	584
1000	1220	580
992	1210	575
984	1200	570
976	1190	565
968	1180	561
951	1160	551

(Y) Interior Mirror Marker Lower Height (mm)	(X) Height To Top Of Lens (mm)	(Z) Nearside Mirror Marker Lower Height (mm)
943	1150	546
935	1140	542
927	1130	537
918	1120	532
910	1110	527
902	1100	523
894	1090	518
886	1080	513
877	1070	508
869	1060	504
861	1050	499
853	1040	494
845	1030	489
836	1020	485
828	1010	480
820	1000	475
812	990	470
804	980	466
795	970	461
787	960	456
779	950	451
771	940	447
763	930	442
754	920	437
746	910	432
738	900	428
730	890	423
722	880	418
713	870	413
705	860	409
697	850	404
689	840	399
681	830	394
672	820	390

Annex 3 Mirror Field of View - Alternative Test Procedure 10

(Y) Interior Mirror Marker Lower Height (mm)	(X) Height To Top Of Lens (mm)	(Z) Nearside Mirror Marker Lower Height (mm)
664	810	385
656	800	380
648	790	375
640	780	371
631	770	366
623	760	361
615	750	356
607	740	352
599	730	347
590	720	342
582	710	337
574	700	333
566	690	328
558	680	323
549	670	318
541	660	314
533	650	309
525	640	304
517	630	299
508	620	295
500	610	290
492	600	285
484	590	280
476	580	276
467	570	271
459	560	266
451	550	261
443	540	257
435	530	252
426	520	247
418	510	242
410	500	238

NOTE: Where the “mirror dimension” is outside the scope of this table the lower marker height for the

- Interior Mirror = “mirror dimension” (height to top of lens) x 82%
- Nearside Mirror = “mirror dimension” (height to top of lens) x 47.5%

10 Mirror Field of View - Alternative Test Procedure Annex 3

Pole and Marker Positions

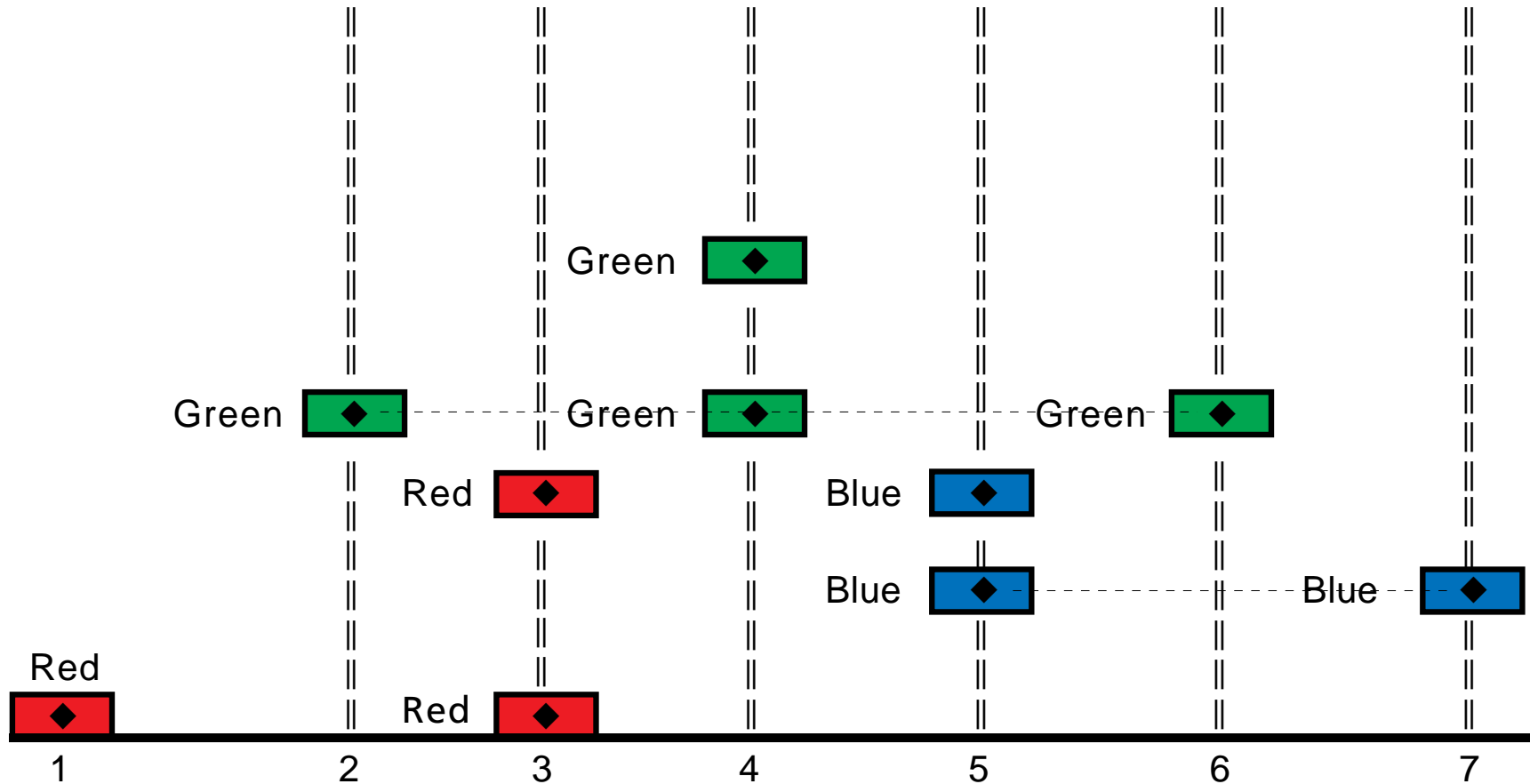

(Not to scale)

Offside Mirror (red markers) - Pole 3 in line with mirror test area line "a", and marker 1 outer edge placed 2.5 metres from pole 3.

Interior Mirror (green markers) - Pole 4 placed on mirror test area centre line "b", and Poles 2 and 6 placed 1.8 metres either side of pole 4.

Nearside Mirror (blue markers) (where required) - Pole 5 in line with mirror test area line "c" and pole 7 placed 2.1 metres from pole 5.

Doors, Latches, Hinges 12

Application	Procedure and Standards	Reasons for Failure
<p>All vehicles except:</p> <ol style="list-style-type: none"> Goods vehicles from item 4b only, doors which do not give direct access to seats which are designed for normal use while the vehicle is travelling on the road, ie where the longitudinal plane of the most inboard point of the door is more than 300mm from the longitudinal plane of the nearest edge of the seat. from items 2 to 5 inclusive, doors designed to be easily attached to or removed from a motor vehicle manufactured for operation without doors. from item 4, any power operated door if the force applied by the power actuator is sufficient to keep the door completely closed even when any load is applied as described in 4b. <p>Note: A side-screen which may be mounted in a structure, and which in either case is hinged to allow entry/exit and which is permanently secured to the vehicle (ie not detachable) is considered to be a door and is subject to the requirements of this section.</p>	<ol style="list-style-type: none"> Check, by opening and closing, that the driver and all passenger entrance and exit doors are capable of being securely latched in the closed position. <ol style="list-style-type: none"> Check the driver's and all passenger entrance/exit door and door apertures <ul style="list-style-type: none"> can be used easily on a vehicle designed to be used with permanently fitted doors, that all edges are blunted on a vehicle designed to be used without doors, that the apertures have no edges contactable with a 165mm dia sphere that has a radius of curvature of less than 2.5mm. Check all door handles/controls are easily accessible from the adjacent seated position. Check all aperture covers (tailgates, boot, bonnet, etc) are capable of being securely latched in the closed position. 	<ol style="list-style-type: none"> A door does not secure in the fully closed position. <ol style="list-style-type: none"> An entrance/exit door/aperture <ul style="list-style-type: none"> provides restricted access on a vehicle fitted with doors has a non-blunted edge on a vehicle designed to be used without doors, has an aperture edge which is contactable with a 165mm dia sphere with a radius of curvature of less than 2.5mm. A door handle/control not accessible from the adjacent seated position. An aperture cover does not secure in the fully closed position.

Cont'd ▼

Cont'd ▼

12 Doors, Latches, Hinges (cont'd)

Application	Procedure and Standards	Reasons for Failure
	<p>4.</p> <p>a. Check each driver/passenger entrance/exit door fitted to the side of the vehicle, has a latch mechanism with both intermediate and fully latched positions, unless the door is fitted with a safety bolt and operational warning device (see item 5).</p> <p>b. Check by visual assessment that each door latch/striker mechanism fitted to a hinged door is capable of withstanding a load of approx 30kgf (66lbf) in both the intermediate and fully latched positions</p> <p>NOTE: A door fitted with a safety bolt with an operational audible warning device need only meet this requirement with the bolt in the secured (locked) position.</p> <p>5.</p> <p>a. Check each driver/passenger door fitted to the side of the vehicle which is hinged at the top or rear (other than a folding door), is either</p> <ul style="list-style-type: none"> ▪ fitted with a device which automatically closes it to at least the intermediate closed position if unlatched when the vehicle is moving forward, or ▪ provided with a safety bolt to prevent the door being unlatched accidentally. <p>b. where a safety bolt is fitted to a top or rear hinged door, check its security and operation and that it is fitted with an audible warning device which activates when the vehicle is driven without the bolt in the secured (locked) position.</p>	<p>4.</p> <p>a. A side entrance/exit door (not being fitted with a safety bolt and operational warning) has a latch that does not provide both an intermediate and fully latched position.</p> <p>b. A passenger entrance/exit door latch/striker mechanism will not withstand a load of 30kgf (66lbf) in both the intermediate (if appropriate) and fully latched positions.</p> <p>5.</p> <p>a. A driver/passenger door fitted to the side of the vehicle which is hinged at the top or rear</p> <ul style="list-style-type: none"> ▪ not fitted with a device which automatically moves it to the closed position if unlatched when the vehicle is moving forward, and ▪ not fitted with a safety bolt to prevent it being unlatched accidentally when the vehicle is moving forward. <p>b. A mandatory door safety bolt assembly</p> <ul style="list-style-type: none"> ▪ insecure ▪ inoperative ▪ not fitted with an audible warning device that operates when the vehicle is driven with the bolt in the unlocked position.

Exterior Projections 13

Application	Procedure and Standards	Reasons for Failure
<p>All vehicles except</p> <p>a. Goods vehicles</p> <p>b. vehicles which are</p> <ul style="list-style-type: none"> ▪ subject to the “Enhanced SVA Requirements” ▪ left hand drive ▪ a personal import ▪ a motor caravan ▪ an ambulance ▪ a hearse, or ▪ an armoured vehicle <p>where the requirements of item 2a shall not apply to any part of the external surface including cosmetic features such as trim and badges as originally manufactured or as subsequently altered in a manner approved by the manufacturer and</p> <ul style="list-style-type: none"> ▪ which is blunted (see item 2b) and ▪ which is not reasonably practicable to remove. <p>c. Motor Ambulances, Motor Caravans, and Hearses other than the area of the driver’s cab and only where the special purpose makes it impossible to fully comply.</p> <p>NOTE 1: Where necessary it is the responsibility of the</p> <p style="text-align: right;">Cont'd ▼</p>	<p>Between the floor line and a height of 2 metres; the “external surface”, there must be no features likely to catch on or increase the risk or seriousness of injury to any person who could come into contact with the vehicle.</p> <p>Floor line means; a theoretical line tracing a succession of points of contact between a cone having a 30° half angle and the external surface of the vehicle. (Excluding jacking points, exhaust pipes where a tailpipe protrudes from under the body and wheels and assuming wheel arches are filled in). (See Annex 2).</p> <p>NOTE: The positioning of a side mounted exhaust may provide the point of contact which determines the floor line.</p> <p>1. Check visually that all mascots, emblems or other ornamental objects which project more than 10mm (including any base) from the mounting surface</p> <ul style="list-style-type: none"> ▪ retract or are likely to detach when a load not exceeding 10kgf (22lbf) is applied ▪ does not project from the mounting surface by more than 10mm when retracted/detached <p>2.</p> <p>a. Check visually (where necessary using measuring equipment) that all hard parts on or protruding by 5mm or more from the external surface, which are contactable with a 100mm dia. sphere have a radius of curvature of not less than 2.5mm. (see application item b)</p> <p>NOTE 1: Where the rear of a bumper is ‘contactable’ this criteria will apply.</p> <p>NOTE 2: The assessment of a registration plate mounting bracket should take account of the likely position of a registration plate. A dummy</p> <p style="text-align: right;">Cont'd ▼</p>	<p>1. A mascot, emblem or other ornamental object</p> <ul style="list-style-type: none"> ▪ does not retract or detach ▪ when retracted or detached leaves a base or other part projecting by more than 10mm. <p>2.</p> <p>a. A hard part which is contactable with a 100mm dia. sphere has a radius of curvature of less than 2.5mm.</p> <p style="text-align: right;">Cont'd ▼</p>

13 Exterior Projections (cont'd)

Application	Procedure and Standards	Reasons for Failure
<p>applicant to prove why it is impossible to comply.</p> <p>NOTE 2: The drivers cab must comply with all the requirements.</p> <p>d. Armoured vehicles on items where the special purpose makes it impossible to comply.</p> <p>NOTE: Where necessary it is the responsibility of the applicant to prove why it is impossible to comply.</p> <p>Exterior Assessment</p> <p>Where a vehicle is not fitted with a facility to attach a hood/roof the interior/exterior boundary should be taken to be the mid-point between interior and exterior on for example the windscreen pillar, top edge of body side, top edge of door. This is however a subjective judgement to be made by the examiner. The examiner should consider the interior to be the passenger compartment including any luggage space within the same compartment. Other areas of the vehicle should be considered to be "exterior" including open "luggage areas"</p> <p>Where the vehicle has a detachable (or fold back) hood/roof, the interior shall be taken to be the area covered by the hood/roof.</p> <p style="text-align: right;">Cont'd ▼</p>	<p>registration plate may be used to assess contactable parts of a bracket against the requirements.</p> <p>b. Check all hard parts on or protruding by 5mm or more from the external surface, which are contactable with a 100mm dia. sphere, and which are exempt by "Application item b" are blunted.</p> <p>NOTE 3: The checks at 'a' and 'b' must be carried out with the steered wheels in the "straight ahead" position only. Exposed steering, suspension or brake components, eg on vehicles fitted with "cycle wing" mudguards, must be checked from the front only. Components contained within the inner wheel "dish", eg brake disc, stub axle assembly, are not subject to this criteria.</p> <p>NOTE 4: Items not normally employed for the specific purpose by a major manufacturer eg a temporary fixing or covering, should not be considered acceptable. Materials, methods and application used in rectification may be accepted if they are permanent, durable and are of a kind which would normally be used by a major manufacturer. In the case of exposed steering/suspension components it will be acceptable to use a "hard" rubber/plastic capping device to cover otherwise exposed threaded fasteners or hard rubber/plastic covering on a threaded steering shaft providing it cannot be easily removed and it complies with the Exterior Projection requirements.</p> <p>NOTE 5: The approval of a lamp (as indicated by the 'e' or 'E' marking) only relates to the performance characteristics of the lamp and does not confirm compliance in respect of Exterior Projections.</p> <p style="text-align: right;">Cont'd ▼</p>	<p>b. A hard part has a non blunted edge.</p> <p style="text-align: right;">Cont'd ▼</p>

Exterior Projections (cont'd) 13

Application	Procedure and Standards	Reasons for Failure
	<p>NOTE 6: The criteria of item 2a does not apply to folds in body panels or to the following items, which must be checked to their individual requirements.</p> <p>c. Check:</p> <p>i. protrusions of less than 5mm, but of more than 1.5mm, are blunted.</p> <p>ii. grills/gaps (eg air intakes or outlets including that part of a grill that projects over the surface of the body and the cooling fins of air cooled engines) having gaps of</p> <ul style="list-style-type: none"> ▪ more than 25mm but not more than 40mm have edges with a radius of curvature of not less than 1mm on any external surface ▪ more than 10mm but not more than 25mm have edges with a radius of curvature of not less than 0.5mm on any external surface ▪ not more than 10mm have edges which are blunted. <p>NOTE: The width of a gap/grill is measured between the contact points of a 100mm dia sphere bridging the gap/grill.</p> <p>iii. windscreen, headlamp and rear window wiper blades and their supports are blunted.</p> <p>iv. wheels, wheel nuts, hub caps or wheel discs do not have any pointed or sharp features (ie all edges must be blunted) which project beyond the external plane of the wheel rim.</p> <p style="text-align: right;">Cont'd ▼</p>	<p>c.</p> <p>i. A protrusion, of less than 5mm but more than 1.5mm has a non-blunted edge.</p> <p>ii. A grill/gap of</p> <ul style="list-style-type: none"> ▪ more than 25mm but not more than 40mm has an edge with an external radius of curvature of less than 1mm ▪ more than 10mm but not more than 25mm has an edge with an external radius of curvature of less than 0.5mm ▪ not more than 10mm has a non-blunted edge. <p>iii. A wiper blade or support has a non-blunted edge.</p> <p>iv. A wheel, wheel nut, hub cap or wheel disc has a pointed or sharp edge which projects beyond the external plane of the wheel rim.</p> <p style="text-align: right;">Cont'd ▼</p>

13 Exterior Projections (cont'd)

Application	Procedure and Standards	Reasons for Failure
	<p>v. wheels</p> <ul style="list-style-type: none"> ▪ which must not be fitted with any wing nut ▪ which, above the horizontal plane passing through the axis of rotation, must not project beyond the vehicle body plan form (other than in the case of tyres, wheel discs and central wheel securing nuts) ▪ on which any wheel disc or central wheel securing nut that projects beyond the vehicle body plan form does not have a radius of curvature of less than 30mm and does not project more than 30mm. <p>vi. sheet metal edges, are folded back on themselves by approx 180°.</p> <p>vii. lateral air or rain deflectors, where any edge capable of being directed outwards requires a radius of curvature of not less than 1mm.</p> <p>viii. fixing holes and recesses less than 12mm diameter have a blunted edge.</p> <p>ix. aerial shafts, which must be fitted with a fixed capping having a radius of curvature of not less than 2.5mm.</p> <p>x. hard parts made of plastic or rubber which are flexible have a blunted edge.</p> <p>xi. FRP (Fibre Reinforced Plastic) panel edges have a radius of curvature of not less than 1.5mm.</p>	<p>v. A wheel</p> <ul style="list-style-type: none"> ▪ is fitted with a wing nut. ▪ projects beyond the vehicle body plan form ▪ with a wheel disc or central securing nut <ul style="list-style-type: none"> – projecting beyond the vehicle body plan form and having a radius of curvature of less than 30mm – which projects beyond the vehicle body plan form more than 30mm. <p>vi. A sheet metal edge not folded back by approx 180°.</p> <p>vii. A lateral air/rain deflector with an outward facing edge that has a radius of curvature of less than 1mm.</p> <p>viii. A hole or recess less than 12mm diameter has a non blunted edge.</p> <p>ix. An aerial shaft not fitted with a fixed capping that has a radius of curvature of at least 2.5mm.</p> <p>x. a plastic or rubber flexible part has a non-blunted edge.</p> <p>xi. An "FRP" panel edge has a radius of less than 1.5mm.</p>

Cont'd ▼

Cont'd ▼

Exterior Projections (cont'd) 13

Application	Procedure and Standards	Reasons for Failure
	<p>3. IN ADDITION to the criteria applicable at item '2' check</p> <p>a. bumpers, that the ends are turned inwards or recessed (integrated) within the bodywork</p> <p>b. handles, hinges and push buttons on doors, luggage compartments, bonnets, covers etc and fuel tank filler caps</p> <p>i. do not project from the external surface more than</p> <ul style="list-style-type: none"> ▪ 50mm where they cannot under any circumstances project beyond the extreme outer edge of the vehicle ▪ 40mm in all other cases. <p>c. all handles</p> <p>i. which rotate parallel to the plane of the door are turned in towards the door.</p> <p>ii. check the open end of any handle that rotates parallel to the plane of the door</p> <ul style="list-style-type: none"> ▪ is directed rearwards, or ▪ if under no circumstances the handle projects beyond the extreme outer edge of the vehicle, either <ul style="list-style-type: none"> – the open end is shielded to the front by a protective surround – the open end is recessed into the vehicle bodywork – the gap measured laterally between the open end of the handle and the vehicle body is not more than 2mm (with the handle in its normal position and the door latched). <p style="text-align: right;">Cont'd ▼</p>	<p>3.</p> <p>a. A bumper end neither</p> <ul style="list-style-type: none"> ▪ turned inwards ▪ recessed. <p>b. A handle, hinge, push button or fuel tank filler cap</p> <ul style="list-style-type: none"> ▪ which does not project beyond the extreme outer edge of the vehicle has a surface projection of more than 50mm ▪ which projects beyond the extreme outer edge of the vehicle has a surface projection of more than 40mm. <p>c. A handle</p> <p>i. which rotates parallel to the plane of the door is not turned in towards the door.</p> <p>ii. a handle (other than a rearward facing handle)</p> <ul style="list-style-type: none"> ▪ projects beyond the extreme outer edge of the vehicle ▪ the open end of which is neither <ul style="list-style-type: none"> – shielded to the front by a protective surround – recessed into the vehicle bodywork – terminating in a gap of not more than 2mm. <p style="text-align: right;">Cont'd ▼</p>

13 Exterior Projections (cont'd)

Application	Procedure and Standards	Reasons for Failure
	<p>iii. that pivot outwards have the open end facing either rearwards or downwards unless</p> <ul style="list-style-type: none"> ▪ they have an independent return mechanism, and ▪ should the return mechanism fail they will not project more than 15mm. <p>d. windows opening outwards from the external surface of the vehicle; that under all conditions of use</p> <ul style="list-style-type: none"> ▪ have no forward facing exposed edges ▪ do not project beyond the extreme outer edge of the vehicle. <p>NOTE: The requirements of item 'd' do not apply to a window fitted to a Motor Ambulance or a Motor Caravan which is fitted to the rear of the driver's seat, and</p> <ul style="list-style-type: none"> ▪ in the case of a Motor Ambulance, is in the medical working area ▪ in the case of a Motor Caravan, is in the living area. <p>e. headlight visors and rims do not project more than 30mm beyond the lens surface (measured horizontally from the point of contact of 100mm dia sphere touching lens and visor rim).</p> <p>f. jacking brackets do not project beyond the floor line lying directly above them by more than 10mm.</p> <p>g. exhaust pipes where the tailpipe projects beyond the floor line lying directly above it by more than 10mm terminate in a radius of curvature of not less than 2.5mm.</p>	<p>iii. which pivots outwards with the open end facing upwards or forwards</p> <ul style="list-style-type: none"> ▪ does not have an independent return mechanism, or ▪ is fitted with an independent return mechanism which in the event of failure would allow the handle to project more than 15mm. <p>d. A window which opens outwards</p> <ol style="list-style-type: none"> i. has a forward facing exposed edge. ii. projects beyond the plan form of the vehicle. <p>e. A headlamp visor or rim projects more than 30mm from the lens surface measurement point.</p> <p>f. A jacking bracket projects beyond the floor line by more than 10mm.</p> <p>g. An exhaust tailpipe which projects beyond the floor line by more than 10mm terminates in a radius of curvature of less than 2.5mm.</p>

This explanatory note provides additional information as an aid to the 74/483/EEC examination of a vehicle in respect of the Exterior Projection requirements contained in Section 13.

The requirements of this section originate mainly from the requirements of Directive 74/483/EEC. This states that "The external surface of the vehicle shall not exhibit, directed outwards, any pointed or sharp parts or any projections of such shape, dimensions, direction or hardness as to be likely to increase the risk or seriousness of bodily injury to a person hit by the external surface or brushing against it in the event of a collision."

The Directive then specifies the criteria by which this shall be achieved.

The "external surface" of the vehicle is the area between the floorline and a height of 2 metres.

The floorline is as defined in Annex 2 of Section 13. As stated, a jacking bracket or an exhaust tailpipe protruding from the body are not included as points of contact when establishing the floorline, however other "hard" features such as a rear fog lamp, wheel guards/ mudflaps, side mounted exhausts, steps etc. if contactable by the cone would be used to determine the floorline.

A "hard" feature is a feature having a hardness of at least 60 Shore A. (In simple "thumb pressure" terms, harder than the average pencil eraser).

Items mounted on the vehicle body (the external surface) e. g. lamps, side mounted exhausts, spare wheels etc., that provide a surface contactable by the sphere, themselves create an external surface. See Fig. 4.

Procedures and Standards item 2a requires the examiner to; "Check visually (where necessary using measuring equipment) that all hard parts on or protruding by 5mm or more from the external surface, which are contactable with a 100mm dia. sphere have a radius of curvature of not less than 2.5mm." In practical terms this is an assessment of the degree by which an item on the exterior of the vehicle would, on impact, penetrate the human body, and if the amount of penetration is 5mm or more that any injury is limited.

In respect of the measurement of a protrusion from the external surface, this should be measured from the surface from which the component is mounted, ie if an item is protruding from the body surface, the height of the item should be measured from the body surface, being the "external surface". Edges of that item contactable by the 100mm diameter sphere that project from the "external surface" by 5mm or more are required to have a radius of curvature of 2.5mm. See Fig. 1 and 2.

An item mounted on the vehicle which itself forms part of the "external surface" (eg a lamp) from which further items project would similarly require those protrusions to be measured from the "external surface" (eg from the surface of the lamp). See Fig. 3 and 4.

One item mounted on another that forms a protrusion from the external surface (eg a badge on a plinth or a bolt having two washers) should be measured to the point of contact using a 100mm sphere. Where the point of contact is 5mm or more above the external surface any contactable edge requires a 2.5mm radius. Where contact with the sphere on the protrusion is at a point less than 5mm from the external surface (but more than 1.5mm) the contactable edge is required to be blunted.

A "groove", "channel" or "recess" on an external surface, must be treated as a "gap". The criteria applicable is subject to the width of the gap being measured between the contact points of a 100mm sphere bridging the "gap", and is that given in item 2c ii.

The radius requirements must be applied to the vehicle "external surface" to the edge of the wheel arch which must be turned inwards, (but if turned in does not need to meet the 2.5mm min. radius requirement). Where the wheel arch does not terminate in a turned in edge the minimum radius requirement (2.5mm.) must be met. The exterior projection requirements must **not** be applied inboard of the "turned in" edge of the wheel arch, ie in the area between wheel and wheel arch.

The edge of a panel constructed of sheet metal (where the panel terminates at a gap, eg surrounding a door, bonnet or boot lid) is required to be folded back on itself by approx. 180°. The edge of a similarly positioned panel constructed of FRP (Fibre Reinforced Plastic) (eg the rear of a bonnet where the windscreen terminates below the bonnet line) must alternatively have a radius of not less than 1.5mm.

13 Exterior Projections - Vehicle Assessment (cont'd) Annex 1

The "Application" column provides exemption (other than in the case of an "Amateur Built" vehicle, a vehicle "Manufactured in very low volume", a vehicle "Manufactured using parts of a registered vehicle" or a "Rebuilt" vehicle), from the requirement of item 2a (protrusions of 5mm or more that are contactable to have a 2.5mm radius) "to any part of the external surface of the vehicle (including cosmetic features such as trim and badges) as originally manufactured or as subsequently altered in a manner approved by the manufacturer **and which it is not reasonably practicable to remove.**"

This criteria applies to the external surface of the vehicle and includes cosmetic features such as trim or badges fitted to the body, these being of particular importance because they are often not practical to remove or modify without defacing the vehicle (ie adversely affecting the body aesthetics). However, it also includes any feature above the "floor line", including accessories such as bull-bars, spot lamps, steps, providing these are original equipment or manufacturer approved, but these are more likely to be practical to remove, modify or replace (eg with an alternative accessory) without defacing the vehicle. In assessing whether the item is or is not "**reasonably practicable to remove**" consideration must be given to whether the permanent removal of the part or removal/rectification and refitting would have an adverse affect on the aesthetics of the vehicle; for example, removal of a manufacturer's original fitment badge or trim strip resulting in holes in the body external surface that would require filling/plugging would have an adverse effect on the aesthetics of the vehicle as would applying a 2.5mm radius to a cast or roll-formed trim and would therefore be considered to be exempt from the radius requirement.

Therefore in brief the considerations are:-

- is the vehicle of a category to which the exemption applies,
- is the item on the "external surface" of the vehicle
- is it reasonably practicable to remove or modify (eg in a body workshop) and
- would such removal or modification have an adverse effect on the body aesthetics.

Annex 1 Exterior Projections - Vehicle Assessment (cont'd) 13

Figure 1

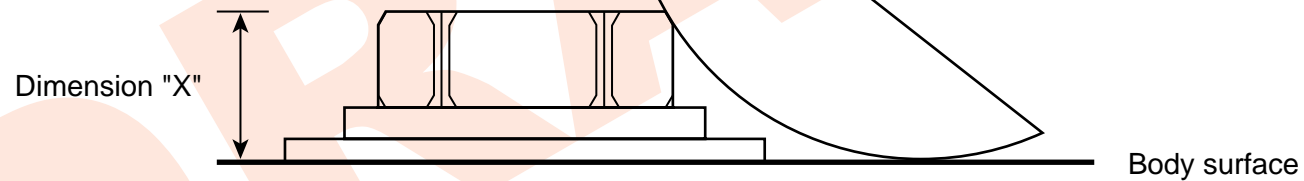

If dimension "X" is 5mm or greater, contactable edge requires a 2.5mm radius

If dimension "X" is less than 5mm (but more than 1.5mm) contactable edge requires to be blunted

13 Exterior Projections - Vehicle Assessment (cont'd) Annex 1

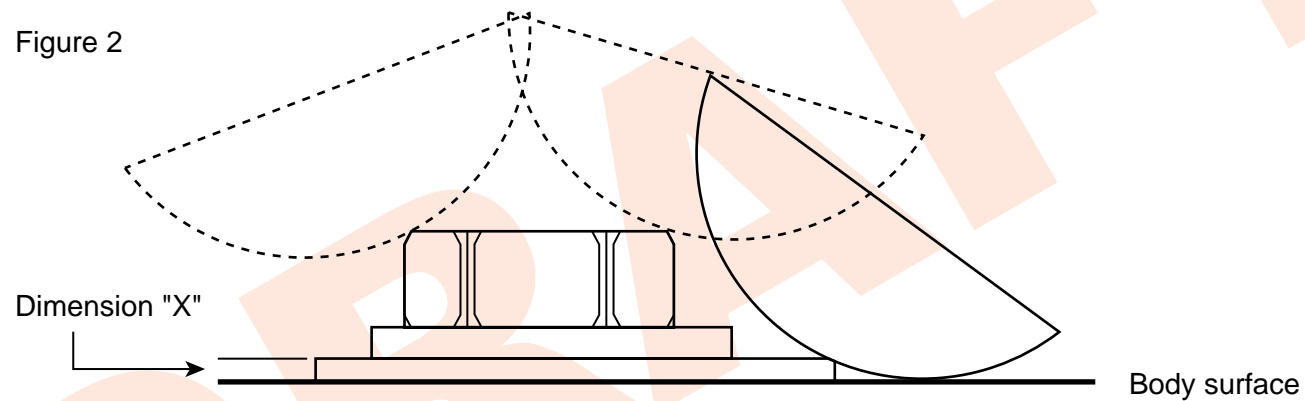

If dimension "X" is 5mm or greater, contactable edge requires a 2.5mm radius

If dimension "X" is less than 5mm (but more than 1.5mm) contactable edge requires to be blunted

Note:

In this example the measurements of the projections are all taken from the "Body surface" as no other "external surface" is provided by the components. (see Fig. 3)

Annex 1 Exterior Projections - Vehicle Assessment (cont'd) 13

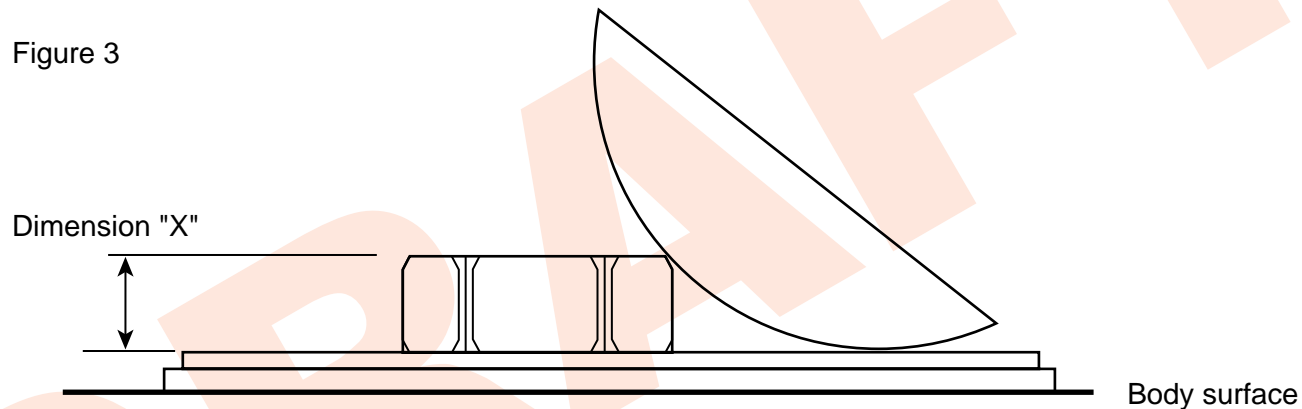

If dimension "X" is 5mm or greater, contactable edge requires a 2.5mm radius

If dimension "X" is less than 5mm (but more than 1.5mm) contactable edge requires to be blunted

Note:

In this example the measurement of the projection of the bolt is taken from the surface of the plate/plinth which itself creates an "external surface". The measurement of the projections of the plate/plinth being taken from the "body surface". (see Fig. 2)

13 Exterior Projections - Vehicle Assessment (cont'd) Annex 1

Figure 4. Consideration of the features of a typical lamp

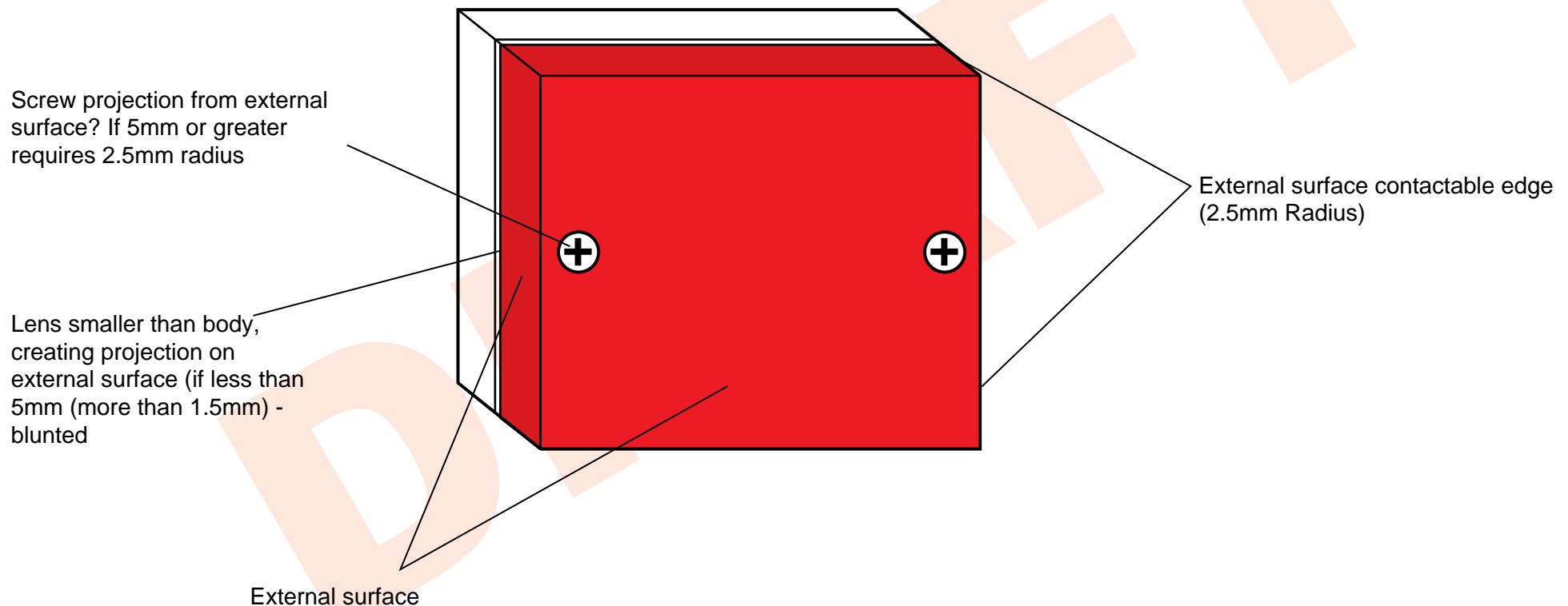

“Items mounted on the vehicle body (external surface) eg lamps, side mounted exhausts, spare wheels etc. that provide a surface contactable by the sphere, themselves from an external surface”

Position the vehicle on a level surface.

Place a cone having a 30° half angle (or cone segment) on the ground such that the conical surface is touching the outer surface of the vehicle to establish a "contact point". (See Fig.1)

Reposition the cone at various locations depending on variations in vehicle shape/ contour around the vehicle to establish a series of "contact points".

The floor line is the theoretical line connecting the established "contact points".

NOTE: Jacking brackets, exhaust tailpipe protrusions from under the body and wheels are not to be taken into account when assessing the floor line and it should be assumed that wheel arches are filled in.

Where an item (other than the body) is contactable by the cone such that the floor line is determined by that item (ie in this example the rear fog lamp), the floor line will be taken to be that applicable had the component not been fitted; However over the width of the component the floor line will become the lower edge of the component. (See Fig.2)

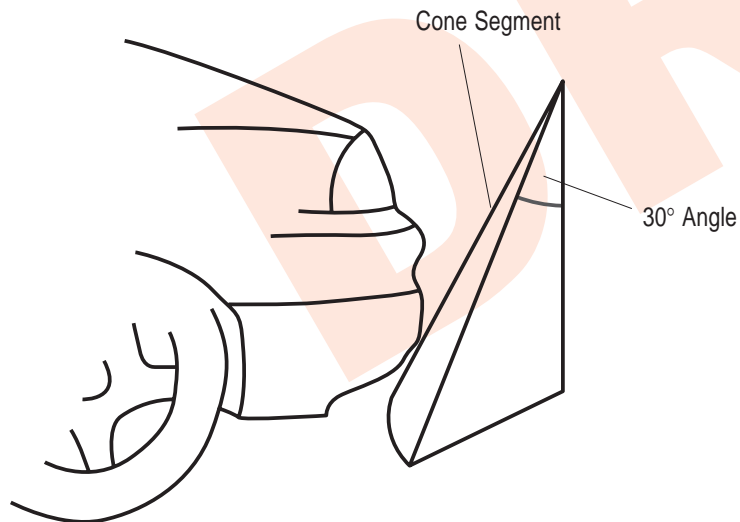

Fig. 1

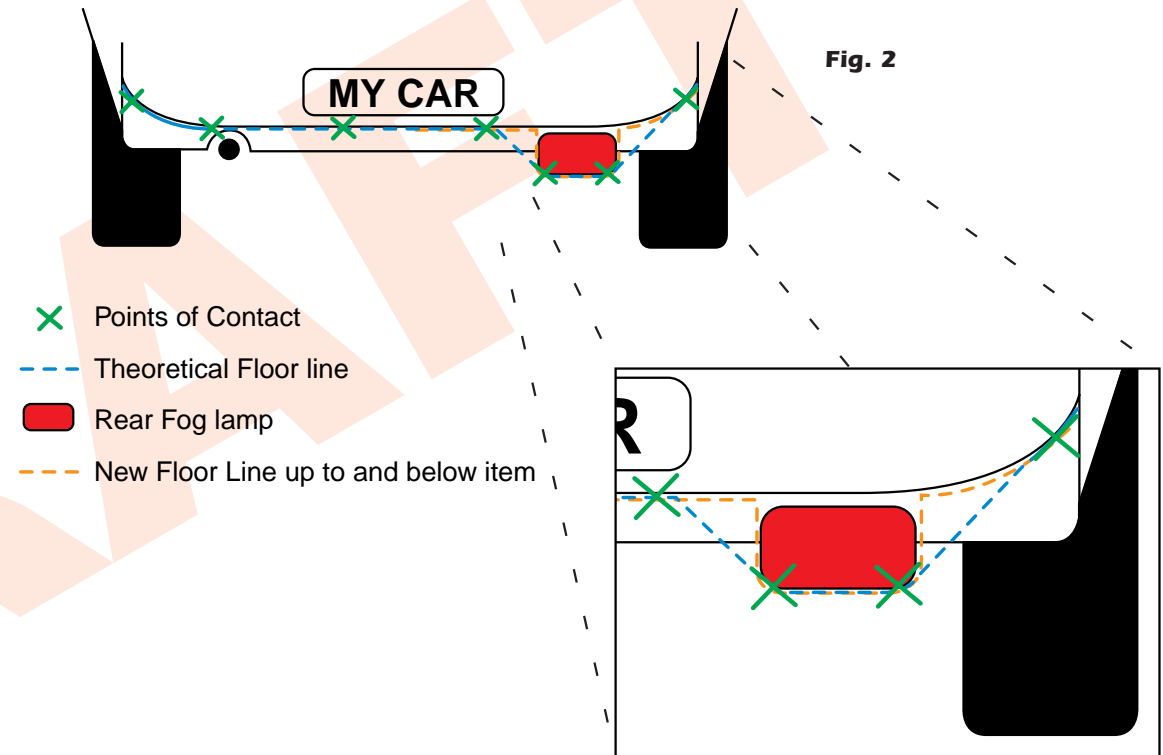

Fig. 2

Protective Steering 14

Application	Procedure and Standards	Reasons for Failure
<p>All vehicles except</p> <ol style="list-style-type: none"> a. Goods vehicles b. Motor Ambulances, Motor Caravans and Hearses having a maximum gross weight of more than 2500kg if the vehicle has been derived from a goods vehicle either <ul style="list-style-type: none"> ▪ having a maximum gross weight of not less than 1500kg, or ▪ manufactured before 1 October 1997 c. Disabled persons vehicles in respect of any adaptation to the steering control only. d. those with forward control manufactured before 1 October 1997 ie a vehicle where the steering wheel centre is in the forward quarter of the length of the vehicle (including bumpers and overiders) e. vehicles which are <ul style="list-style-type: none"> ▪ subject to "Enhanced SVA Requirements" ▪ left hand drive ▪ a personal import ▪ a motor caravan ▪ an ambulance, or ▪ a hearse <p style="text-align: right;">Cont'd ▼</p>	<p>Check that the steering control provides adequate protection from injury to the driver during normal driving and in the event of vehicle frontal impact.</p> <ol style="list-style-type: none"> 1a. The steering control surface directed towards the driver, which can be contacted by a sphere of 165mm dia should have no edges with a radius of curvature of less than 2.5mm (see Application, items e and g). 1b. In respect of a vehicle to which item 1a does not apply (see application item "e" and "g"), check all parts of the steering control including any switch that is an integral part of the steering control, is blunted. 2. The steering wheel must be designed, constructed and fitted so as not to catch in the driver's clothing or jewellery during normal driving movement, eg no rim supports manufactured from plate containing holes. <p>NOTE: The checks at items 1 and 2 are not necessary if the steering wheel is a type approved component.</p> 3. <ol style="list-style-type: none"> a. The steering wheel and column assembly must offer a degree of protection to the driver by absorbing energy from a driver-wheel impact. From markings, documentary evidence and/or assessment, check that <ol style="list-style-type: none"> i. the wheel and column is a previously type approved assembly fitted using the original approved mountings or a comparable mounting arrangement with similar strength characteristics; or <p style="text-align: right;">Cont'd ▼</p>	<ol style="list-style-type: none"> 1a. A part of the steering control surface directed towards the driver which can be contacted with a sphere of 165mm dia has a radius of curvature of less than 2.5mm. 1b. A steering control feature not blunted. 2. Operation of the steering wheel through normal driving movement is likely to result in the driver's clothing or jewellery catching in the steering wheel assembly. 3. <ol style="list-style-type: none"> a. The steering wheel and column assembly <ol style="list-style-type: none"> i. is not a previously type approved wheel and column assembly being fitted using the original approved mountings or a comparable mounting arrangement; and <p style="text-align: right;">Cont'd ▼</p>

14 Protective Steering (cont'd)

Application	Procedure and Standards	Reasons for Failure
<p>where the requirements of item 1a only do not apply if the vehicle</p> <ul style="list-style-type: none"> - is fitted with a driver's air bag - the driver's air bag was fitted in time of manufacture - complies with item 1b. <p>f. Armoured vehicles</p> <p>g. vehicles which are</p> <ul style="list-style-type: none"> ▪ subject to the "Enhanced SVA Requirements" ▪ left hand drive ▪ a personal import ▪ a motor caravan ▪ an ambulance, or ▪ a hearse <p>where the requirements of item 1a only do not apply to any switch fitted to the steering control if it</p> <ul style="list-style-type: none"> ▪ is an integral part of the steering control as originally fitted by the manufacturer, ▪ can be depressed into the steering control by finger pressure, ▪ complies with item 1b. 	<p>ii. the steering wheel is a type approved component displaying an acceptable approval marking and which is fitted with an energy absorption feature eg "collapsible boss" accompanied by documentary evidence to confirm the assembly specification relative to the approval</p> <p>NOTE: An approval marking on a steering wheel does not itself confirm compliance, as the wheel may be approved as part of an assembly incorporating an energy absorption hub or similar feature, or</p> <p>iii. there is sufficient evidence that the steering wheel or wheel and column provide equivalent protection to that of an approved component (see Annex).</p> <p>NOTE: An approved component is required to absorb energy during an impact test. The impact test uses a "body block" or "headform" travelling at a relative speed of 24.1 km/h.</p> <p>The component must provide protection by controlling the rate of deceleration of the impactor on impact (for example by use of compressible material or deformation).</p> <p>Following the test there must not be any sharp or rough edges on the component likely to increase the danger or severity of injury to the driver.</p>	<p>ii. the steering wheel is not a Type Approved component displaying an acceptable approval marking and fitted with an energy absorption feature or accompanied by documentary evidence to confirm the assembly specification relative to the approval; and</p> <p>iii. neither the wheel and column assembly or the wheel alone provides equivalent protection to that required by an approved wheel, or approved wheel/column assembly.</p>

Cont'd ▼

Cont'd ▼

Protective Steering (cont'd) 14

Application	Procedure and Standards	Reasons for Failure
	<p>b. Where a steering wheel incorporating a secondary restraint system (air bag) is fitted to</p> <ul style="list-style-type: none"> ▪ an Amateur Built vehicle ▪ a vehicle for which it was not specifically designed ▪ a vehicle the structure of which has been modified so that the operation of the air bag may be affected <p>check that it either</p> <p>i.</p> <ul style="list-style-type: none"> ▪ incorporates an internal trigger mechanism in the wheel/upper column, and ▪ it can be demonstrated to be a previously approved component, or 	<p>b. A steering wheel incorporating an airbag fitted to:</p> <ul style="list-style-type: none"> ▪ an amateur built vehicle ▪ a vehicle for which it was not designed ▪ a modified vehicle <p>i. is not a previously approved component with an internal trigger mechanism, and</p>

Cont'd ▼

Cont'd ▼

14 Protective Steering (cont'd)

Application	Procedure and Standards	Reasons for Failure
	<p>ii.</p> <ul style="list-style-type: none"> ▪ it incorporates an external trigger mechanism, and ▪ is accompanied by satisfactory evidence from the vehicle or equipment manufacturer or a recognised test authority that the airbag is capable of satisfactory operation on the vehicle as presented, and ▪ it can be demonstrated that the wheel meets the impact requirements of Directive 74/297 or provides equivalent protection to that of an approved component, or <p>iii.</p> <ul style="list-style-type: none"> ▪ it has been designed to be operated by an external trigger mechanism, and no such device is fitted, and ▪ it can be demonstrated that the restraint system is not under any circumstances capable of being deployed, eg by electrical interference, and ▪ it can be demonstrated that the wheel meets the impact requirements of Directive 74/297 or provides an equivalent protection to that of an approved component. 	<p>ii. in the case of a device connected to an external trigger mechanism is not accompanied by acceptable evidence that</p> <ul style="list-style-type: none"> ▪ the airbag is capable of satisfactory operation, and ▪ the wheel is a previously approved component or provides equivalent protection to that of an approved component, and <p>iii. in the case of a device designed to be operated by an external trigger mechanism with no such device fitted</p> <ul style="list-style-type: none"> ▪ is capable of being deployed ▪ the wheel is not a previously approved component (approved without the operation of the airbag) ▪ the wheel does not provide equivalent protection to that of an approved component.

Cont'd ▼

Cont'd ▼

Protective Steering (cont'd) 14

Application	Procedure and Standards	Reasons for Failure
	<p>4.</p> <p>a. The vehicle and steering column assembly must provide that in the event of a frontal impact at 48.3km/h (30mph) the rearward horizontal displacement and vertical displacement of the top of the steering column and its shaft must not exceed 127mm. This criteria may be deemed to be met if on assessment the floor plan/chassis, suspension, steering column assembly and engine fitment (if front engined) for example are comparable to that of a known type approved vehicle (see Annex).</p> <p>A vehicle may be assessed on its merits but will invariably require the steering column shaft to incorporate an arrangement of universal joints/couplings and/or a collapsible tube/slider section that ensures displacement of the upper column is minimised.</p> <p>b. The steering column upper mounting and its supporting cross bearer/bulkhead must be of adequate strength to resist upper column movement in the event of a frontal impact, so as to ensure operation of any column displacement design feature or collapsible component.</p>	<p>4.</p> <p>a. When assessed in relation to the vehicle design characteristics, the steering column and its shaft do not incorporate an adequate design feature likely to minimise upper column displacement during a vehicle frontal impact.</p> <p>b. A steering column upper mounting or its supporting cross bearer/bulkhead,</p> <ul style="list-style-type: none"> ▪ insecure ▪ of inadequate strength to ensure operation of a feature designed to provide column displacement or operation of a collapsible component.

Vehicle Design and Construction – General **15.1***

(Inc. Chassis, Suspension, Steering)

Application	Procedure and Standards	Reasons for Failure
<p>All vehicles</p> <p>NOTE: In the case of Normal Production vehicles, i.e. those which are not</p> <ul style="list-style-type: none"> ▪ an “Amateur Built” vehicle, ▪ a vehicle manufactured in very low volume, ▪ a vehicle “Manufactured using parts of a registered vehicle,” ▪ a “Rebuilt” vehicle, <p>the standards in this section may be considered to be met unless evidence suggests otherwise.</p>	<p>NOTE: This section DOES NOT APPLY to subjects covered in other parts of this manual.</p> <ol style="list-style-type: none"> 1. Check all aspects of the design and construction of the vehicle or its equipment are such that no danger is caused or likely to be caused to any person in the vehicle or to other road users. 2. The following checks must take account of the vehicle’s use under all normal conditions including when it is laden to its maximum permitted axle/ gross vehicle weight. <p>The vehicle may be driven to confirm compliance.</p> <ol style="list-style-type: none"> a. Check the vehicle can be controlled safely, taking into account the vehicle’s speed and acceleration characteristics. <p>NOTE 1: Steering “self centring” action; If driven at a constant speed in excess of 10mph a degree of “self centring” action should be provided by the characteristics of the vehicle design. This does not apply to a Disabled Person’s vehicle fitted with a steering control specifically designed for the use of a person having a disability and not incorporating the use of the original manufacturer’s steering wheel.</p> <p>NOTE 2: A television monitor which can be seen from the driving position, capable of operation when the vehicle is in motion is only considered acceptable if it provides either</p> <ul style="list-style-type: none"> ▪ visibility to the rear of the vehicle ▪ navigation map ▪ vehicle specific information <p>or a combination of these items.</p> <p style="text-align: right;">Cont’d ▼</p>	<ol style="list-style-type: none"> 1. A design or construction feature or characteristic is, or is likely to cause, a danger to any person in the vehicle or to other road users. 2. <ol style="list-style-type: none"> a. When driven, the safe control of the vehicle is or is likely to be impaired due to a design or construction feature or characteristic. <p style="text-align: right;">Cont’d ▼</p>

15.1 * Vehicle Design and Construction – General (cont'd)

(Inc. Chassis, Suspension, Steering)

Application	Procedure and Standards	Reasons for Failure
	<p>b. Check the design and construction of the vehicle structure (chassis or integral chassis/body including subframes) and assess its ability to withstand the forces and vibration to which it is likely to be subject.</p> <p>Consideration must be given to the loadings imposed due to acceleration, braking and cornering, particularly when the vehicle is at its maximum permitted axle/gross vehicle weight.</p> <p>c. Check the design, construction and attachment of each subframe mounting and assess its ability to withstand the forces and vibration to which it may be subject.</p> <p>3. With the front wheels resting on turning plates and the wheels turned from lock to lock, check the vehicle (front to rear) for fouling under any normal load condition of</p> <ul style="list-style-type: none"> ▪ wheels and tyres ▪ transmission/braking components which rotate during vehicle operation ▪ steering components. 	<p>b. The vehicle structure</p> <ul style="list-style-type: none"> i. is of inadequate strength and likely to fail prematurely ii. has an assembly component eg, bolt, rivet etc, <ul style="list-style-type: none"> ▪ insecure ▪ missing ▪ of inadequate strength and likely to fail prematurely. iii. has a welded joint cracked or of inadequate strength and likely to fail prematurely. <p>c. A subframe/mounting attachment bracket</p> <ul style="list-style-type: none"> ▪ insecure ▪ of inadequate strength and likely to fail prematurely ▪ securing method of inadequate strength and likely to fail prematurely. <p>3. A transmission/braking component which rotates during vehicle operation, steering component, wheel or tyre</p> <ul style="list-style-type: none"> ▪ fouling on another component, or ▪ likely to foul under normal operating conditions.

Cont'd ▼

Cont'd ▼

Vehicle Design and Construction – General (cont'd) 15.1*

(Inc. Chassis, Suspension, Steering)

Application	Procedure and Standards	Reasons for Failure
	<p>4. Check visually the design, construction and attachment of each</p> <ul style="list-style-type: none"> ▪ wheel ▪ axle/stub axle ▪ suspension assembly ▪ steering component. <p>and assess its ability to withstand the forces and vibration to which it may be subject.</p>	<p>4.</p> <ul style="list-style-type: none"> a. A wheel <ul style="list-style-type: none"> ▪ securing device missing/insecure ▪ incompatible with its mounting/securing arrangement ▪ of inadequate strength and likely to fail prematurely. b. An axle/stub axle <ul style="list-style-type: none"> i. of inadequate strength and likely to fail prematurely ii. mounting arrangement or bracket <ul style="list-style-type: none"> ▪ of inadequate strength and likely to fail prematurely ▪ insecure. c. A suspension unit <ul style="list-style-type: none"> i. of inadequate strength and likely to fail prematurely ii. likely to foul other parts of the vehicle iii. insecure, so that it may become displaced iv. shackle, anchor or linkage pin <ul style="list-style-type: none"> ▪ missing/insecure ▪ of inadequate strength and likely to fail prematurely ▪ locking device missing/insecure v. anchor, shackle or attachment bracket <ul style="list-style-type: none"> ▪ of inadequate strength and likely to fail prematurely ▪ insecure to the vehicle structure ▪ securing method of inadequate strength and likely to fail prematurely ▪ retaining device missing/insecure.

Cont'd ▼

15.1 * Vehicle Design and Construction – General (cont'd)

(Inc. Chassis, Suspension, Steering)

Application	Procedure and Standards	Reasons for Failure
		<ul style="list-style-type: none"> vi. fluid or gas system <ul style="list-style-type: none"> ▪ leaking ▪ pipe insecure ▪ has a component fouled or likely to be fouled by a moving part. d. A steering component <ul style="list-style-type: none"> i. of inadequate strength and likely to fail prematurely ii. insecure iii. mounting bracket <ul style="list-style-type: none"> ▪ of inadequate strength and likely to fail prematurely ▪ insecure ▪ securing method of inadequate strength and likely to fail prematurely.

DRAFT

Vehicle Design and Construction – General **15.2***

(Fuel/Electrical Systems)

Application	Procedure and Standards	Reasons for Failure
<p>All vehicles</p> <p>NOTE: In the case of Normal Production vehicles, i.e. those which are not</p> <ul style="list-style-type: none"> ▪ an “Amateur Built” vehicle, ▪ a vehicle manufactured in very low volume, ▪ a vehicle “Manufactured using parts of a registered vehicle,” ▪ a “Rebuilt” vehicle, <p>the standards in this section (other than item 1b) may be considered to be met unless evidence suggests otherwise.</p>	<p>1.</p> <p>a. Check all fuel system components (eg fuel tank, pump, filter connectors, etc) and fuel pipes for</p> <ul style="list-style-type: none"> ▪ leaks ▪ security ▪ suitability of design/construction ▪ positioning. <p>An assessment should be made of their construction in respect of their ability to withstand the forces, vibration, and environment to which they may be subject.</p> <p>Components should be positioned such as to minimise the risk of fire in the event of a fuel leak.</p> <p>b. On vehicles that require a “Catalyst Test” (see Section 18, page 2), check that the fuel tank cannot be filled directly from a petrol pump nozzle having an external diameter of 23.6mm or more.</p> <p>NOTE: In order to comply as far as practicable a device fitted to reduce the diameter of the fuel filler tube must be fitted as near to the top of the filler tube as possible, allowing for the filler cap to seal correctly.</p> <p>c. Check fuel tank filler caps for presence, security and to ensure that, when closed, they will not allow fuel to leak.</p>	<p>1.</p> <p>a. A fuel system component</p> <ul style="list-style-type: none"> i. insecure ii. subject to forces or vibration likely to cause premature failure iii. subject to a corrosive environment likely to cause premature failure iv. fouling or likely to be fouled by moving parts of the vehicle v. leaking vi. positioned near a heat source eg exhaust system, so that a leak would cause a fire hazard. <p>b. A fuel filler tube/neck having a minimum internal diameter of 23.6mm or more.</p> <p>c. A fuel tank filler cap</p> <ul style="list-style-type: none"> i. not fitted ii. <ul style="list-style-type: none"> ▪ not secured by a positive means ▪ not incorporating an adequate sealing arrangement so that a fuel leak is possible.

Cont'd ▼

Cont'd ▼

15.2* Vehicle Design and Construction – General (cont'd)

(Fuel/Electrical Systems)

Application	Procedure and Standards	Reasons for Failure
	<p>2. Check all electrical cable and component</p> <ul style="list-style-type: none"> ▪ security ▪ insulation ▪ positioning ▪ capacity. <p>NOTE 1: This inspection is limited to the parts which can be seen without dismantling.</p> <p>NOTE 2: Components must be constructed and positioned so that the risk of corrosion and fire is minimised. Consideration must be given to the original design characteristics of the component.</p> <p>NOTE 3: Electrical wiring must be routed to prevent damage to the insulation and, unless contained in a hollow component, secured at intervals of not more than 300mm (12").</p> <p>NOTE 4: Items not normally employed for the specific purpose by a major manufacturer should not be considered acceptable. eg adhesive tape or self adhesive pads are acceptable if used correctly within the vehicle but are unlikely to be used by a vehicle manufacturer on the underside of the vehicle.</p> <p>Consideration must be given to each individual method and its compatibility with the component being attached and to the environment in which it is fitted. Materials and methods used may be accepted if they are permanent, durable and are of a kind which would normally be used by a major manufacturer.</p>	<p>2.</p> <ul style="list-style-type: none"> a. An electrical component (eg battery ,starter, alternator, fuel pump, etc) <ul style="list-style-type: none"> i. insecure ii. conductor material exposed such that operation would result in a potential short circuit iii. subject to a corrosive environment iv. of inadequate capacity – such that operation is likely to cause an electrical overload. b. An electrical cable/wire <ul style="list-style-type: none"> i. not securely clipped to the vehicle ii. conductor material exposed such that operation would result in a potential short circuit iii. positioned so that <ul style="list-style-type: none"> ▪ it is chaffing or likely to chafe ▪ the insulation is likely to be damaged by heat. iv. of inadequate capacity – such that operation is likely to cause an electrical overload.

Brakes 16.1*

(Braking Systems)

Application	Procedure and Standards	Reasons for Failure
<p>All vehicles except</p> <ol style="list-style-type: none"> a. those subject to the requirements of item E16 of the "Enhanced SVA Requirements", other than in respect of a Disabled Person's vehicle where any adaptation or part of the system affected by an adaptation is subject to the requirements of this section. b. in the case of a Disabled Person's vehicle where the requirement for the driver to keep both hands on the steering control when applying the service brake and one hand on the steering control when applying the secondary brake shall not apply providing adaptations to the controls for use by the disabled driver allows him/her to control the steering at all times while operating either braking system. 	<ol style="list-style-type: none"> 1. Braking Systems Check that the vehicle is fitted with a braking system or systems capable of performing the following braking functions. <ol style="list-style-type: none"> a. Service Capable of being operated <ol style="list-style-type: none"> i. on all wheels by a single means of operation ii. from the driver's seat (keeping both hands on the steering control) iii. to slow down the vehicle when it is moving in a forward or reverse direction. b. Secondary <ol style="list-style-type: none"> i. Vehicles with four or more wheels Capable of operating via either half of a split circuit service brake system on at least two wheels (one on each side) in the event of failure of the service brake or its power assistance. ii. Three-wheeled vehicles Capable of progressive operation via a split circuit service brake system or via the parking brake control by the driver from the driving position (keeping at least one hand on the steering control). 	<ol style="list-style-type: none"> 1. <ol style="list-style-type: none"> a. The vehicle service brake system is not capable of being operated <ol style="list-style-type: none"> i. on all wheels by a single means of operation ii. from the driver's seat while keeping both hands on the steering control iii. to slow down the vehicle when it is moving in a forward or reverse direction. b. <ol style="list-style-type: none"> i. A four (or more) wheeled vehicle is not fitted with a split (dual) circuit service brake system with each part of the system operating on at least two wheels (one on each side). ii. A three-wheeled vehicle <ul style="list-style-type: none"> ▪ does not have a split circuit service brake, and ▪ does not have a parking brake control capable of being applied progressively from the driving position while keeping one hand on the steering control.

Cont'd ▼

Cont'd ▼

16.1 * Brakes (cont'd)

(Braking Systems)

Application	Procedure and Standards	Reasons for Failure
	<p>c. Parking Capable of being operated</p> <ul style="list-style-type: none"> ▪ easily by the driver from the driving position ▪ whether the vehicle is stationary or moving (it must be possible to apply and release the brake while the vehicle is moving) ▪ on all the wheels of at least one axle enabling the vehicle to be held on an up or down gradient ▪ using a control which is independent of the service brake, and capable once applied of being maintained in the 'on' position solely by a mechanical means. 	<p>c. The vehicle parking brake system</p> <ul style="list-style-type: none"> i. is not capable of being operated <ul style="list-style-type: none"> ▪ easily from the driving position ▪ whether the vehicle is stationary or moving ▪ on all the wheels of at least one axle so as to hold the vehicle on an up or down gradient ▪ using an independent control. ii. is not capable of being maintained in the 'on' position by a purely mechanical means.

Brakes 16.2*

(Service Brake Control/Mechanical Components)

Application	Procedure and Standards	Reasons for Failure
<p>All vehicles except</p> <p>a. those subject to the requirements of item E16 of the "Enhanced SVA Requirements", other than in respect of a disabled person's vehicle where any adaptation or part of the system affected by an adaptation is subject to the requirements of this section.</p> <p>b. three-wheeled vehicles in respect of item 2e only.</p>	<p>2. Service Brake Control/Mechanical Components</p> <p>a. Check the brake control can be operated easily from the driving position without obstruction or abnormal foot position and that the pedal has an anti-slip provision.</p> <p>b. Check visually the pedal, brake actuating linkage (eg to remote master cylinder) and associated components for suitability of</p> <ul style="list-style-type: none"> ▪ design ▪ construction methods/materials ▪ location ▪ mounting/fixing to vehicle structure. <p>All components must be suitable to withstand the stresses, vibration, corrosion and ageing (allowing for routine maintenance) to which they may be subject.</p> <p>Check the brake control and operating linkage are of suitable strength to minimise the risk of failure under the most arduous conditions and are accessible for maintenance.</p> <p>NOTE: A linkage that incorporates an adjustable device that adjusts the front/rear braking ratio (longitudinal brake distribution) may require adjustment prior to the brake performance test (see Section 16.5, Item 5.1).</p> <p style="text-align: right;">Cont'd ▼</p>	<p>2.</p> <p>a. A brake pedal</p> <ul style="list-style-type: none"> i. not easily operated from the driving position due to <ul style="list-style-type: none"> ▪ restricted access ▪ control positioning. ii. anti-slip provision <ul style="list-style-type: none"> ▪ not fitted ▪ insecure ▪ inadequate. <p>b. A brake pedal, actuating linkage or associated component</p> <ul style="list-style-type: none"> i. is not fully accessible for maintenance purposes. ii. incomplete, so that it does not function correctly. iii. of inadequate strength and likely to fail prematurely. iv. made of a material insufficiently durable and likely to fail prematurely. v. obstructed in its travel or fouling parts of the vehicle. vi. mounting/bracket <ul style="list-style-type: none"> ▪ of inadequate strength and likely to fail prematurely ▪ insecure to the vehicle structure ▪ securing method of inadequate strength and likely to fail prematurely. <p style="text-align: right;">Cont'd ▼</p>

16.2* Brakes (cont'd)

(Service Brake Control/Mechanical Components)

Application	Procedure and Standards	Reasons for Failure
	<p>c. Depress the pedal fully and check the position of the pedal relative to the floor, ie for reserve travel.</p> <p>d. Hydraulic systems (including servo assisted)</p> <p>i. Fully depress the pedal twice, first slowly and then rapidly each time to a point where sustained pressure can be held. Check for creep and sponginess.</p> <p>ii. If a vacuum servo is fitted, with the engine off, totally deplete the stored vacuum. Fully apply the brake. Note whether the pedal can be felt to travel further when the engine is started.</p> <p>NOTE: Servo operation may not be detected when the brake is fully applied. In this situation the vehicle should be re-checked with the brake "partially" applied.</p> <p style="text-align: right;">Cont'd ▼</p>	<p>vii. pivot bearing/bush</p> <ul style="list-style-type: none"> ▪ of inadequate strength and likely to fail prematurely ▪ insecure such that it is likely to become displaced. <p>viii. pivot/linkage pin</p> <ul style="list-style-type: none"> ▪ missing ▪ insecure. <p>ix. locking or retaining device missing/insecure.</p> <p>c. With the brake pedal fully depressed there is insufficient reserve pedal movement.</p> <p>d.</p> <p>i. The pedal tends to creep down while it is held under pressure.</p> <p>ii. Sponginess indicating air in the hydraulic system.</p> <p>iii. No dip can be felt when the engine is started, indicating vacuum assistance is not working satisfactorily.</p> <p style="text-align: right;">Cont'd ▼</p>

Brakes (cont'd) 16.2*

(Service Brake Control/Mechanical Components)

Application	Procedure and Standards	Reasons for Failure
	<p>e. Full power hydraulic braking systems (other than three wheeled vehicles)</p> <p style="padding-left: 20px;">i. Check that a warning device is fitted and is audible or visible to the driver.</p> <p>f. Check the security of all mechanical components, eg brake drums, back plates, brake shoes, discs, callipers, pads including friction material.</p> <p>g. Check where possible, (without dismantling) each brake assembly incorporates an adjustment/compensation capability to compensate for friction material wear. On a front axle of a vehicle (other than a three-wheeled vehicle) this must be provided automatically.</p>	<p>e.</p> <p style="padding-left: 20px;">i. A warning device</p> <ul style="list-style-type: none"> ▪ not fitted ▪ not working correctly ▪ not visible (or audible) to the driver. <p style="padding-left: 20px;">ii. A visual warning device not readily visible to the driver in darkness.</p> <p>f.</p> <p style="padding-left: 20px;">i. A brake mechanical component eg drum/disc, back plate/calliper, shoe/pad</p> <ul style="list-style-type: none"> ▪ insecure ▪ securing bolt missing/insecure ▪ locking or retaining device missing/insecure. <p style="padding-left: 20px;">ii. A friction material missing/insecure.</p> <p>g. A brake assembly</p> <ul style="list-style-type: none"> ▪ on a FRONT axle of a vehicle with four or more wheels, does not incorporate a means of automatically compensating for friction material wear. ▪ on a FRONT axle of a three-wheeled vehicle, does not incorporate either a manual or automatic means of compensating for friction material wear. ▪ on a REAR axle, does not incorporate either a manual or automatic means of compensating for friction material wear.

Cont'd ▼

Cont'd ▼

16.2* Brakes (cont'd)

(Service Brake Control/Mechanical Components)

Application	Procedure and Standards	Reasons for Failure
	<p>h. Assess the ability of the brake friction surfaces to dissipate energy sufficiently to maintain the required braking performance under all normal conditions (including long descents) without the occurrence of "brake fade".</p> <p>The assessment must take account of the vehicle's weight, weight distribution and speed capability. The criteria may be deemed to be met if on assessment all the relevant factors for example are comparable to that of a known type approved vehicle.</p> <p>The vehicle owner may be required to provide evidence that the criteria can be met.</p>	<p>h. The brake friction surfaces have insufficient capacity to dissipate heat and prevent fade.</p>

Brakes 16.3*

(Parking Brake Control/Mechanical Components)

Application	Procedure and Standards	Reasons for Failure
<p>All vehicles except</p> <p>a. those subject to the requirements of item E16 of the "Enhanced SVA Requirements", other than in respect of a disabled person's vehicle where any adaptation or part of the system affected by an adaptation is subject to the requirements of this section.</p>	<p>3. Parking Brake Control/Mechanical Components</p> <p>a. With the brake in both the on and off positions respectively, check the lever, actuating linkage, cables and associated components for suitability of</p> <ul style="list-style-type: none"> ▪ design ▪ construction methods/materials ▪ location ▪ mounting/fixing to vehicle structure. 	<p>3.</p> <p>a. A parking brake lever, actuating linkage, cable or associated component</p> <ul style="list-style-type: none"> i. incomplete, so that it does not function correctly ii. of inadequate strength and likely to fail prematurely iii. made of a material insufficiently durable and likely to fail prematurely iv. obstructed in its travel or fouling parts of the vehicle v. mounting/bracket <ul style="list-style-type: none"> ▪ insecure to the vehicle structure ▪ of inadequate strength and likely to fail prematurely. ▪ securing method of inadequate strength and likely to fail prematurely. vi. pivot bearing/bush <ul style="list-style-type: none"> ▪ of inadequate strength and likely to fail prematurely ▪ insecure, so that it is likely to become displaced. vii. pivot/linkage pin <ul style="list-style-type: none"> ▪ missing ▪ insecure. viii. locking or retaining device missing/insecure.

Cont'd ▼

Cont'd ▼

16.3* Brakes (cont'd)

(Parking Brake Control/Mechanical Components)

Application	Procedure and Standards	Reasons for Failure
	<p>All components must be suitable to withstand the stresses, vibration, corrosion and ageing (allowing for routine maintenance) to which they may be subject.</p> <p>b. Without operating the pawl release mechanism, apply the parking brake slowly and check the effective operation of the pawl mechanism.</p> <p>c.</p> <p>i. in the case of a lever operated brake, with the brake applied, check that it cannot be disengaged by knocking the lever on each side and the top and check if the lever is at the end of its working travel.</p> <p>ii. in the case of an electrically operated parking brake, check either</p> <ul style="list-style-type: none"> ▪ the switch is protected from inadvertent use, or ▪ with the ignition off, the switch is capable of applying the brake, but is not capable of releasing the brake. <p>d. Check the linkage mechanism for a means of</p> <ul style="list-style-type: none"> ▪ compensation between all brake assemblies operated by the parking brake control ▪ adjustment (manual or automatic) to compensate for wear. 	<p>b. The ratchet pawl is not engaging positively with the ratchet teeth.</p> <p>c.</p> <p>i. The lever operated brake</p> <ul style="list-style-type: none"> ▪ is not held in the "on" position when knocked ▪ cannot be positively held at a position of further travel. <p>ii. The brake control switch</p> <ul style="list-style-type: none"> ▪ is not protected from inadvertent use, and ▪ does not follow the required sequence of operation (See Procedure and Standards) <p>d. The linkage mechanism does not incorporate a means of</p> <ul style="list-style-type: none"> ▪ compensation ▪ adjustment.

Brakes 16.4*

(Hydraulic and Vacuum Systems)

Application	Procedure and Standards	Reasons for Failure
<p>All vehicles except</p> <p>a. those subject to the requirements of item E16 of the "Enhanced SVA Requirements", other than in respect of a disabled person's vehicle where any adaptation or part of the system affected by an adaptation is subject to the requirements of this section.</p> <p>b. three-wheeled vehicles which are not required to comply with items 'cii', 'ciii' and 'd'.</p>	<p>4. Hydraulic and Vacuum Systems</p> <p>a. Where practicable, check all hydraulic and vacuum components, eg master cylinders, wheel cylinders, valves, servos, reservoirs, pipes and hoses for suitability of</p> <ul style="list-style-type: none"> ▪ design ▪ construction methods and materials ▪ location ▪ mounting/fixing to the vehicle structure, stub axle or other component. <p>All components must be suitable to withstand the stresses, vibration, corrosion and ageing (allowing for routine maintenance) to which they may be subject.</p> <p>Compression joints of the type using separate ferrules are not considered suitable for joints on hydraulic brake lines other than in the case of a hose designed for a high pressure application that incorporates an inner support sleeve in the compression fitting.</p> <p>b. Check for leaks in any part of the braking system, with and without the brake applied. For vehicles fitted with a vacuum servo or power braking system, the engine must be idling during this inspection.</p>	<p>4.</p> <p>a.</p> <p>i. A hydraulic or vacuum brake component (including pipes/hoses)</p> <ul style="list-style-type: none"> ▪ incomplete so that it does not function correctly ▪ of inadequate strength and likely to fail prematurely ▪ made of a material insufficiently durable and likely to fail prematurely. ▪ mounting/bracket <ul style="list-style-type: none"> – insecure to the vehicle structure or another component – of inadequate strength and likely to fail prematurely. – securing method of inadequate strength and likely to fail prematurely. <p>ii. A brake pipe or hose (hydraulic/vacuum)</p> <ul style="list-style-type: none"> ▪ fouled by moving parts ▪ kinked, stretched or twisted ▪ inadequately clipped or otherwise supported ▪ with unsuitable joint fittings ▪ exposed to excessive heat. <p>iii. A hydraulic/vacuum component subject to a corrosive environment and likely to fail prematurely.</p> <p>b. A component leaking air or fluid due to a constructional defect.</p>

Cont'd ▼

Cont'd ▼

16.4* Brakes (cont'd)

(Hydraulic and Vacuum Systems)

Application	Procedure and Standards	Reasons for Failure
	<p>c.</p> <p>i. Check that, on all fluid reservoirs, the filling ports are</p> <ul style="list-style-type: none"> ▪ readily accessible ▪ fitted with caps. <p>NOTE: The following items ii and iii do not apply to three-wheeled vehicles.</p> <p>ii. On all fluid reservoirs, it must be possible without opening the reservoir, to check the fluid level relative to the manufacturer's specified minimum level by</p> <ul style="list-style-type: none"> ▪ the actual fluid level being visible through a transparent section of the reservoir and with the minimum level permanently marked on or adjacent to this section, or ▪ a red warning lamp capable of illuminating when the reservoir fluid falls to the minimum level. <p>iii. Where a warning lamp is provided as the only means of checking the fluid level without opening the reservoir, check the warning lamp is</p> <ul style="list-style-type: none"> ▪ secure ▪ operational ▪ visible during daylight and darkness from the driving position ▪ fitted with an operational "test facility" that enables its operation to be checked from the driving position without opening the reservoir. <p style="text-align: right;">Cont'd ▼</p>	<p>c.</p> <p>i. A fluid reservoir</p> <ul style="list-style-type: none"> ▪ filling port not readily accessible ▪ cap missing/insecure. <p>ii. A fluid reservoir</p> <ul style="list-style-type: none"> ▪ not having a transparent section through which the fluid level is visible, and a permanent "minimum" level mark, and ▪ not fitted with a red warning lamp capable of illuminating when the fluid level falls to the 'minimum' safe level. <p>iii. A warning lamp provided as the only means of checking the fluid level without opening the reservoir</p> <ul style="list-style-type: none"> ▪ insecure ▪ inoperative ▪ not visible at all times from the driving position ▪ not fitted with an operational "test facility" to check its operation from the driving position without opening the reservoir. <p style="text-align: right;">Cont'd ▼</p>

Brakes (cont'd) 16.4*

(Hydraulic and Vacuum Systems)

Application	Procedure and Standards	Reasons for Failure
	<p>d. NOTE: Items di, dii and diii do not apply to three-wheeled vehicles.</p> <p>i. Check the hydraulic system is fitted with a red warning lamp.</p> <p>ii. Check the warning lamp is</p> <ul style="list-style-type: none"> ▪ operated by a pressure sensitive device capable of signalling the failure of any part of the hydraulic system as soon as the brake is applied and remaining lit as long as the failure exists (when the ignition is on), or ▪ sensitive to the reservoir fluid level providing the reservoir is directly connected to supply the pressure side of the master cylinder when the piston is in the "brakes off" position, ie a failure of either part of the split system would result in a continuous draining of the reservoir fluid when the control is released. <p>NOTE: In the case of a conventional split system (with/without vacuum assistance) it will be assumed that a failure will result in the draining of the reservoir fluid.</p> <p>Evidence of system operation will be required, for example, in the case of a Full Power Hydraulic System.</p>	<p>d.</p> <p>i. A hydraulic system not fitted with a red warning lamp.</p> <p>ii. A hydraulic system warning lamp</p> <ul style="list-style-type: none"> ▪ not sensitive to line pressures and capable of signalling a failure as soon as the brake is applied and remaining lit as long as the failure exists, and ▪ not sensitive to a fall in reservoir fluid level (when the control is at rest) as a result of a system failure.

Cont'd ▼

Cont'd ▼

16.4* Brakes (cont'd)

(Hydraulic and Vacuum Systems)

Application	Procedure and Standards	Reasons for Failure
	<p>iii. Check the warning lamp is</p> <ul style="list-style-type: none"> ▪ secure ▪ operational ▪ visible during daylight and darkness from the driving position ▪ identifiable (ie labelled in a recognised form) ▪ fitted with an operational "test facility" that enables its operation to be checked from the driving position. <p>NOTE 1: It may be necessary to confirm the fluid circuit through the master cylinder by documentary evidence.</p> <p>NOTE 2: One reservoir fluid level warning lamp may fulfil the function of checking the fluid level (item 'c') and monitoring the hydraulic system (item 'd') providing both criteria are met.</p> <p>NOTE 3: "labelled in a recognised form" means displaying a symbol recognised by the motor industry (eg a circle containing an exclamation mark with brake shoe segments on either side) on the illuminating surface.</p> <div style="text-align: center;">  </div> <p style="text-align: right;">Cont'd ▼</p>	<p>iii. A warning lamp</p> <ul style="list-style-type: none"> ▪ insecure ▪ inoperative ▪ not visible at all times from the driving position ▪ not identifiable ▪ not fitted with an operational "test facility" to check its operation from the driving position. <p style="text-align: right;">Cont'd ▼</p>

Brakes (cont'd) 16.4*

(Hydraulic and Vacuum Systems)

Application	Procedure and Standards	Reasons for Failure
	<p>e. If the vehicle is fitted with an anti-lock (ABS) braking system</p> <ul style="list-style-type: none"> i. check for evidence of malfunction, eg a component missing, damaged, insecure or disconnected such that the system is unlikely to function as intended. ii. check that a system warning lamp <ul style="list-style-type: none"> ▪ is fitted to monitor the system ▪ is visible from the driving position ▪ is operational ▪ operates when the anti-lock is energised and 'goes out' at the latest when the vehicle speed reaches 10km/h. 	<p>e. An anti-lock system</p> <ul style="list-style-type: none"> i. component missing, damaged, insecure or disconnected such that the system is unlikely to function as intended. ii. warning lamp <ul style="list-style-type: none"> ▪ not fitted ▪ not visible from the driving position ▪ inoperative ▪ remains on at vehicle speeds in excess of 10km/h

DRAFT

Brakes 16.5*

(Brake Performance)

Application	Procedure and Standards	Reasons for Failure
<p>All vehicles except</p> <ul style="list-style-type: none"> a. those subject to the requirements of item E16 of the "Enhanced SVA Requirements", other than in respect of a disabled person's vehicle where any adaptation or part of the system affected by an adaptation is subject to the requirements of this section. b. three wheeled vehicles in respect of item 5e only c. vehicles which are <ul style="list-style-type: none"> ▪ left hand drive ▪ a personal import ▪ an ambulance ▪ a hearse, or ▪ an armoured vehicle ▪ a vehicle manufactured in very low volume <p>where the requirements of item 5.1c only (Longitudinal Brake Distribution) shall not apply if</p> <ul style="list-style-type: none"> ▪ the brakes on the rear wheels are fitted with an anti-lock device which was fitted at the time of manufacture, and ▪ it appears that the anti-lock device complies with the definition in Directive 71/320/EEC, eg it <p style="text-align: right;">Cont'd ▼</p>	<p>5.1 Roller Brake Test</p> <p>A vehicle that incorporates an adjustment device (eg pedal linkage balance bar) that adjusts the front/rear braking ratio (longitudinal brake distribution) must be tested in the "worst case" condition, ie maximum rear axle braking.</p> <p>NOTE: Devices that allow further adjustment, eg lock nuts/adjustable stops, split pins, will not, in isolation be considered as capable of preventing further adjustment to a "worse" condition. (A roll pin will be considered acceptable providing it penetrates the full diameter of the component.)</p> <p>The vehicle presenter may be required to adjust any such device in order to comply with this condition prior to the brake performance test.</p> <p>Certain vehicles should not be tested on a roller brake tester, eg vehicles with</p> <ul style="list-style-type: none"> ▪ more than one driving axle permanently engaged ▪ belt-driven transmission ▪ brakes for which the servo operates only when the vehicle is moving. <p>These vehicles should be tested using a calibrated decelerometer or a plate brake tester.</p> <p>Vehicles fitted with a limited-slip differential must be tested on the roller brake tester. If due to vehicle design, it is found that the roller brake tester cannot be used, the vehicle must be tested using a calibrated decelerometer.</p> <p>Vehicles with damaged, under inflated or studded tyres may not be considered to be in a suitable condition to carry out a brake performance test.</p> <p style="text-align: right;">Cont'd ▼</p>	<p style="text-align: right;">Cont'd ▼</p>

16.5* Brakes (cont'd)

(Brake Performance)

Application	Procedure and Standards	Reasons for Failure
<p>comprises sensors, control valves and/or modulators to modulate the braking force of any wheel(s) that are about to "lock".</p> <p style="text-align: right;">Cont'd ▼</p>	<p>Vehicles with automatic transmission must never be roller brake tested with the gear selector in the "P" park position.</p> <p>For vehicles with servo assisted or power braking systems, the engine must be idling while the service brake is being tested other than for the brake distribution test (item c) the depleted vacuum test (item 'd') and the power hydraulic system test (item 'e').</p> <p>Fit a brake pedal effort measuring device before conducting the test.</p> <p>NOTE: In some cases, it may be necessary to chock the wheels not under test.</p> <p>When testing "light weight" vehicles both rear wheels must be chocked when testing the front axle. This helps to prevent the front of the vehicle "lifting" in the rollers and may improve the efficiency reading obtained before wheel lock.</p> <p>Brake performance should be checked with the braking surfaces (disc/drum/lining/pads) at working temperature. It is acceptable to induce heat into the braking surfaces prior to conducting the test particularly where the vehicle has been transported to the test site.</p> <p>a. Position the front wheels of the vehicle in the rollers of the brake tester and then run both sets of rollers together to align the vehicle. With one set of rollers revolving at a time, gradually depress the service brake until maximum effort is achieved, or until the wheel locks.</p> <p>Record the reading at which the maximum braking effort is achieved for each wheel and whether "lock-up" occurs. Release the service brake.</p> <p style="text-align: right;">Cont'd ▼</p>	<p style="text-align: center;">5.1</p> <p>a.</p> <ul style="list-style-type: none"> i. A low braking effort is recorded from the brake on any wheel, indicating clearly that the brake is not functioning correctly. ii. The calculated service brake efficiency is below the minimum required (see Annex). <p>NOTE 1: The service brake percentage efficiency is considered satisfactory providing wheel lock occurs on more than half of the wheels braked by the service brake.</p> <p style="text-align: right;">Cont'd ▼</p>

Brakes (cont'd) 16.5*

(Brake Performance)

Application	Procedure and Standards	Reasons for Failure
		<p>NOTE 2: Goods vehicles only. When testing service brake performance on unladen vehicles</p> <ul style="list-style-type: none"> ▪ premature wheel lock can occur, and ▪ less than the required brake effort is achieved. <p>The required brake effort might not be achieved due to the action of load sensing/pressure reducing equipment in the service brake system.</p> <p>In either of these cases, the service brake percentage efficiency is considered satisfactory if</p> <ul style="list-style-type: none"> ▪ more than half the wheels lock, or ▪ both front wheels lock and at least 100kg (220lb) is achieved by each rear wheel, or ▪ for three axle vehicles; both front wheels lock and at least 50kg (110lb) is achieved by each rear wheel.

DRAFT

Cont'd ▼

Cont'd ▼

16.5* Brakes (cont'd)

(Brake Performance)

Application	Procedure and Standards	Reasons for Failure
	<p>b. Start both sets of rollers and note whether a significant brake effort is recorded from any wheel without a brake being applied. Gradually depress the service brake and watch how the braking effort for each wheel increases. From the previous tests you will know the value at which wheel slip occurs. Aim to stop just short of this, ie without wheel-lock. Gradually release the service brake and observe how the braking effort at each wheel reduces checking that the pedal returns to the fully off position. Stop the rollers.</p> <p>Record the out-of-balance in braking effort between wheels on either side of the vehicle.</p>	<p>b.</p> <ul style="list-style-type: none"> i. A significant braking effort recorded on a road wheel, even though the brake is not applied, indicating that a brake is binding. ii. Evidence of severe brake grab or judder as the brake is applied. iii. The braking efforts at the road wheels of an axle do not increase progressively at about the same rate when the service brake is applied gradually. iv. The braking efforts at the road wheels of an axle do not reduce at about the same rate when the service brake is released gradually. v. The brake pedal does not return to the fully off position. vi. The brake effort of one wheel is less than 70% of the effort recorded from the other wheel on any steering axle. (see note 2) <p>NOTE 1: Disregard any brake “imbalance” when the brake effort from each wheel on the axle is less than 40kg.</p> <p>NOTE 2: A “steering axle” is an axle that provides the main source of directional control of the vehicle.</p>

Cont'd ▼

Cont'd ▼

Brakes (cont'd) 16.5*

(Brake Performance)

Application	Procedure and Standards	Reasons for Failure
	<p>c. With the engine 'off', deplete all the vacuum from the servo reservoir (if fitted).</p> <p>NOTE: In the case of a power hydraulic system, the pressure should not be depleted.</p> <p>Start both sets of rollers and observing the load cell, progressively apply the service brake in increments, for example, of 10kg. Aim to stop just short of the value at which wheel-slip occurs.</p> <p>Record the brake effort obtained at each wheel for every increment of effort applied to the brake pedal. Stop the rollers.</p> <p>Where the vehicle is fitted with</p> <ul style="list-style-type: none"> ▪ a vacuum servo proceed with item (d) ▪ a power hydraulic system (not being a three wheeled vehicle), proceed with item (e). <p>otherwise continue with item (f).</p> <p>d. With one set of rollers revolving at a time and with the vacuum depleted as in "c" (observing the load cell) apply the secondary brake (which is the foot brake where the secondary is a split system) with a control effort in the case of a:-</p> <p>4 or more wheeled passenger vehicle - foot control, 50kg</p> <p>4 or more wheeled goods vehicle - foot control, 70kg</p> <p>4 or more wheeled passenger vehicle - other than foot control, 40kg</p> <p>4 or more wheeled goods vehicle - other than foot control, 60kg</p> <p>3 wheeled vehicle - foot control, 50kg</p> <p style="text-align: right;">Cont'd ▼</p>	<p>c. The braking ratio of the axles is not, for all values of total brake force less than the friction force ratio (taking account of weight transfer) between axles with the vehicle in running order.</p> <p>d. The calculated secondary brake efficiency</p> <ol style="list-style-type: none"> i. in the case of a 4 or more wheeled passenger vehicle is less than 30% ii. in the case of a 4 or more wheeled goods vehicle is less than 25% iii. in the case of a 3 wheeled vehicle is less than 25% <p style="text-align: right;">Cont'd ▼</p>

16.5* Brakes (cont'd)

(Brake Performance)

Application	Procedure and Standards	Reasons for Failure
	<p>3 wheeled vehicle - other than foot control 40kg.</p> <p>NOTE 1: If the control reaches the end of its travel before the full effort is applied the test should be conducted at maximum travel.</p> <p>Record the brake effort obtained from each wheel (without vacuum assistance). Stop the rollers. Continue with item (f).</p> <p>NOTE 2: This item applies to all service brake controls that actuate a secondary brake system fitted to the vehicle. eg any additional control fitted to a disabled person's vehicle that operates the secondary split system.</p> <p>e. Gradually deplete the stored energy until the pressure warning device operates.</p> <p>Carry out four full stroke applications of the service brake.</p> <p>Start both sets of rollers and gradually depress the service brake until maximum effort is achieved, or until wheel lock. Record the readings at which maximum effort is achieved.</p> <p>Release the service brake.</p>	<p>e. The calculated service brake efficiency after four full applications is less than 30% (in the case of a goods vehicle, 25%).</p>

Brakes (cont'd) 16.5*

(Brake Performance)

Application	Procedure and Standards	Reasons for Failure
	<p>f. If the vehicle has a parking brake, which operates on the axle being tested, repeat the process outlined in 'a' above using this brake and, where possible, keeping the "hold-on" button or trigger in the disengaged position the whole time.</p> <p>NOTE: For testing transmission handbrakes see item 5.3.</p> <p>g. In the case of a three-wheeled vehicle where the same control is used to actuate the parking brake and secondary brake, operate the brake control (as in 'f' above) applying a maximum effort of 40kg to the control. Record the brake effort obtained.</p> <p>h. Release the brakes and drive the vehicle forward until the rear wheels are in the rollers.</p> <p>Repeat operations (a) to (g) for each rear axle recording the brake efforts obtained during each operation.</p> <p>With reference to the annex to this section and using the brake figures recorded, calculate the value of each relevant item listed in the table and assess the result obtained against the minimum requirement.</p> <p style="text-align: right;">Cont'd ▼</p>	<p>f.</p> <p>i. A low braking effort is recorded from the parking brake on any wheel, indicating clearly that the brake is not functioning correctly.</p> <p>ii. The calculated parking brake efficiency is less than 18%.</p> <p>NOTE: The parking brake percentage efficiency is considered satisfactory providing wheel lock occurs on more than half of the wheels braked by the parking brake.</p> <p>g. In the case of a three-wheeled vehicle only, where the secondary brake utilises the park brake control the calculated secondary brake efficiency for a control effort of 40kg is less than 25%</p> <p>NOTE: The secondary brake efficiency is considered satisfactory providing wheel lock occurs on more than half of the wheels braked by the secondary brake.</p> <p style="text-align: right;">Cont'd ▼</p>

16.5* Brakes (cont'd)

(Brake Performance)

Application	Procedure and Standards	Reasons for Failure
<p>All vehicles except</p> <p>Normal Production vehicles, i.e. those which are not</p> <ul style="list-style-type: none"> ▪ an "Amateur Built" vehicle, ▪ a vehicle "Manufactured using parts of a registered vehicle," ▪ a "Rebuilt" vehicle, <p>where the requirements of item 5.2bv only (Longitudinal Brake Distribution) shall not apply if</p> <ul style="list-style-type: none"> ▪ the brakes on the rear wheels are fitted with an anti-lock device which was fitted at the time of manufacture, and ▪ it appears that the anti-lock device complies with the definition in Directive 71/320/EEC or any equivalent standard, eg it comprises sensors, control valve and/or <p style="text-align: right;">Cont'd ▼</p>	<p>i. In the case of a vehicle having a device that adjusts the front/rear braking ratio (as described in the first paragraph of this section), adjust the mechanism to the minimum rear axle braking position.</p> <p>NOTE: The vehicle presenter may be required to adjust the device.</p> <p>For each axle in turn repeat operation "a" recording the brake efforts obtained. With reference to the annex to this section and using the brake figures recorded calculate the service brake efficiency.</p> <p>5.2 Decelerometer Test</p> <p>This method of test must only be used where the vehicle, due to a design characteristic cannot be tested on a Roller Brake Tester.</p> <p>A vehicle that incorporates an adjustment device that adjusts the front/rear braking ratio (longitudinal brake distribution) must be tested in the maximum rear axle braking position.</p> <p>The vehicle presenter may be required to adjust any such device in order to comply with this condition prior to the brake performance test.</p> <p>Set up the decelerometer in the vehicle in accordance with the equipment manufacturer's instructions.</p> <p>a. Drive the vehicle on a level road at a steady speed of approximately 20mph (32km/h) and note the brake efficiency recorded when progressively applying only</p> <ul style="list-style-type: none"> i. the service brake ii. the parking brake. <p style="text-align: right;">Cont'd ▼</p>	<p>i. The calculated service brake efficiency (with the brake distribution adjustment device set to give minimum rear brake effort) is below the minimum requirement.</p> <p>NOTE: The service brake percentage efficiency is considered satisfactory providing wheel lock occurs on more than half of the wheels braked by the service brake.</p> <p style="text-align: center;">5.2</p> <p>a.</p> <ul style="list-style-type: none"> i. The service brake efficiency recorded is below the minimum required ii. In the case of a three-wheeled vehicle where the secondary brake utilises the <p style="text-align: right;">Cont'd ▼</p>

Brakes (cont'd) 16.5*

(Brake Performance)

Application	Procedure and Standards	Reasons for Failure
<p>modulators to modulate the braking force of any wheel(s) that are about to “lock”.</p>	<p>NOTE: If the required efficiencies are seen to be met during application of any brake system under test, release the brake to decrease the effort applied once the required efficiency has been met (if it is deemed safe to do so).</p> <p>b. During the test of the service brake observe (by the use of an assistant if necessary) whether</p> <ul style="list-style-type: none"> i. braking is progressive ii. there is any grab or judder iii. the vehicle deviates to the left or right under braking iv. the brake pedal returns to the fully off position. <p>c. Drive the vehicle on a level road at a steady speed of approximately 20mph (32km/h) and apply the service brake sufficient only to obtain wheel lock. Observe whether all the wheels of the rear axle(s) “lock” prior to both wheels of the front axle indicating an incorrect front/rear brake distribution. It may be necessary to repeat this operation to determine the order of wheel lock.</p> <p>NOTE: The presenter or another person may be required to drive the vehicle under the direction of the examiner.</p> <p>The examiner must then become the observer.</p> <p>d. In the case of a vehicle having a device that adjusts the front/rear braking ratio (as described in the second paragraph of this section), adjust the mechanism to the minimum rear axle braking position.</p> <p>NOTE: The vehicle presenter may be required to adjust the device.</p> <p>Repeat operation ‘a’ applying the service brake and record the efficiency obtained.</p> <p style="text-align: right;">Cont'd ▼</p>	<p>parking brake control, the secondary brake efficiency recorded is less than 25%.</p> <ul style="list-style-type: none"> iii. The parking brake efficiency recorded is less than 18%. <p>b. When the service brake is applied</p> <ul style="list-style-type: none"> i. the brake is not capable of progressive operation ii. there is severe grab or judder iii. the vehicle deviates to the left or right iv. the pedal does not return to the fully off position <p>c. All wheels of the rear axle(s) “lock” prior to both wheels of the front axle.</p> <p>d. The service brake efficiency (with the brake distribution adjustment device set to give minimum rear brake effort) is below the minimum requirement.</p>

16.5* Brakes (cont'd)

(Brake Performance)

Application	Procedure and Standards	Reasons for Failure
<p>All vehicles.</p>	<p>5.3 Transmission Handbrakes</p> <p>a. Place the wheels to be tested in the rollers. Run both sets of rollers together to align the vehicle. Chock the other wheels of the vehicle in front of and behind each wheel. Run both sets of rollers together. Keep the handbrake ratchet disengaged for as long as the brake is applied. Apply the brake slowly and progressively without causing transmission snatch. Record the gauge readings and calculate the brake efficiency.</p> <p>b. In the case of a three-wheeled vehicle where the same control is used to actuate the parking brake and the secondary brake, operate the control (as in 'a' above) using a maximum effort of approximately 40kg. Record the brake effort obtained.</p>	<p>5.3</p> <p>a. The transmission parking brake efficiency is less than 18%.</p> <p>b. A three-wheeled vehicle secondary brake efficiency is less than 25%.</p>

1. LONGITUDINAL BRAKE DISTRIBUTION (Front/Rear braking ratio)

The longitudinal brake distribution (ratio) is calculated using the brake efforts recorded at each wheel for a given pedal effort 'x' using the equation

$$\frac{\text{Total Rear Axle Brake Effort (f}_2\text{)}}{\text{Total Front Axle Brake Effort (f}_1\text{)}} = \text{Braking ratio at 'x' pedal effort}$$

This calculation must be carried out for each pedal effort increment and the ratios obtained compared with the corresponding friction force ratio calculated by using the following equations

- a. Front Axle Max Tyre/Road Friction Force

$$F_1 = \left(W_1 + \left(W_T \times \frac{h}{e} \times \frac{(f_1 + f_2)}{W_T} \right) \right) \frac{(f_1 + f_2)}{W_T}$$

- b. Rear Axle Max Tyre/Road Friction Force

$$F_2 = \left(W_2 - \left(W_T \times \frac{h}{e} \times \frac{(f_1 + f_2)}{W_T} \right) \right) \frac{(f_1 + f_2)}{W_T}$$

Where W = weight in 'running order', h = C of G,
e = wheelbase and f = brake effort,
1, 2 or T (total) = axles.

$$\text{Friction force ratio} = \frac{F_2}{F_1}$$

Application	Procedure and Standards	Reasons for Failure
<p>All vehicles propelled by an internal combustion engine except those subject to the requirements of item E17 of the "Enhanced SVA Requirements".</p>	<ol style="list-style-type: none"> 1. Check the exhaust system is complete, is fitted with a silencer and is secure to the vehicle. NOTE: The following assessment must be completed even in cases where the exhaust system is holed/leaking due to deterioration. 2. Position the vehicle on an unobstructed test site (concrete or asphalt) which covers a rectangular area the sides of which are at least 3 metres from the vehicle sides, front and rear. Ensure the engine is at normal operating temperature. Using a sound level meter of 'Type 1' (as defined in BSEN 5969 or IEC651) to the manufacturers instructions, carry out a static noise check. NOTE: This check may be carried out following the emission test. Place the microphone <ul style="list-style-type: none"> ▪ at the height of the exhaust outlet, or a height of 200mm, whichever is the higher ▪ at an angle of 45° to the exhaust outlet in the direction which gives the greatest possible distance between it and the vehicle contour ▪ at a distance of 500mm from the exhaust outlet. NOTE: If the exhaust has several outlets which are not more than 300mm apart and which are connected to the same silencer, the microphone must face the outlet closest to the vehicle contour or the highest above the ground. In all other cases, separate measurements must be taken, the highest recorded being the test value. 	<ol style="list-style-type: none"> 1. An exhaust system <ul style="list-style-type: none"> ▪ incomplete ▪ not fitted with a silencer ▪ mounting or component insecure ▪ mounting of inadequate strength to support the weight of the system. 2. The measured sound level is more than 101 db(A).

Cont'd ▼

17* Noise (cont'd)

Application	Procedure and Standards	Reasons for Failure
	<p>Run the engine at a constant speed of $\frac{3}{4}$ of its maximum power speed</p> <p>eg. the speed at which maximum power is produced is 6,000 rpm, therefore the test is conducted at 4,500 rpm.</p> <p>Check the level of sound emitted.</p> <p>NOTE: Where the engine maximum power speed is not available, the test may be carried out at $\frac{2}{3}$ engine maximum design speed.</p>	

DRAFT

Exhaust Emissions (Spark Ignition) 18*

Emission Test - General.

1. Application

This section is applicable to all vehicles having a spark ignition engine except

- a) those where the engine is used to generate electricity to propel the vehicle (an electric hybrid vehicle).
- b) those subject to the requirements of item E18 of the "Enhanced SVA Requirements".

2. The Exhaust Emission Test

Two of the exhaust gases are included

- carbon monoxide (CO)
- hydrocarbons (HC)

Assessment on most vehicles is straightforward, but a number of factors covered in the following items should be borne in mind.

3. Conducting the Test

The test should be conducted with the engine warm. Testing a cold engine could lead to an unjustified failure.

It is important to ensure that any enrichment device to aid cold starting is not operating. *see note.

The engine should be idling normally during the test and should not be subject to significant electrical loading such as heated seats or heated rear windows.

If an engine will not idle, an assistant may apply light throttle pedal pressure.

NOTE: If the vehicle is fitted with a remote air/fuel ratio adjustment device

provided to give variable mixture control during vehicle operation it must be tested in both minimum/maximum positions.

4. Engine electric cooling fans - Non Cat Test.

Many modern vehicles are fitted with electric cooling fans which can cut in during an emission test. The extra load on the alternator reduces the idle speed, which causes the engine management system to react. This gives rise to highly variable readings. If this happens during a test, wait until the fan switches off and the readings stabilise before continuing.

Cat. Test.

If during a catalyst test the engine cooling fan cuts in or out, this is not a problem and the test should continue as normal. (All other accessories should be turned off).

5. Unstable readings

Some vehicles give unstable readings due, for example, to their carburetor or fuel injection system design. Before failing a vehicle, it is important to establish that a particular limit has been exceeded constantly for a period of 5 seconds.

6. Holed exhaust

A holed exhaust can allow air to be sucked in causing artificially low readings. In order to carry out the test effectively the exhaust system must be in a satisfactory condition. If the system is holed or leaking such that the result is likely to be affected the emissions test must be deferred until rectification has been carried out.

7. Total gas emitted

The limits prescribed relate to the total exhaust gas being emitted by the vehicle.

If a vehicle has a dual exhaust system, then the emissions from the tailpipes should be averaged. This is done by adding together the readings and dividing by two, e.g.

1st pipe emits 6% CO, 400ppm HC
2nd pipe emits 4% CO, 500ppm HC

Average CO reading is $\frac{6 + 4}{2} = 5\%$

Average HC reading is $\frac{400 + 500}{2} = 450 \text{ ppm}$

i) Single exhaust systems

A single exhaust system has at least one point in the system where all the exhaust gases from the engine travel through the same pipe, even though the system may split at some point to separate silencers or tailpipes. Only one of these need be checked.

ii) Dual exhaust system

A dual exhaust system has two separate pipes from the engine manifold all the way back to the tailpipes. An exhaust system with a balance tube between separate pipes is still considered a dual exhaust.

8. Gas "mono" fueled vehicles

These are vehicles that can run on petrol or gas, but where the petrol system is fitted for emergency purposes or for starting only and the petrol tank has a capacity of not more than 15 litres. These vehicles must be tested only when running on gas.

9. Multi fuel vehicles

Vehicles which run on more than one fuel (e.g. petrol and LPG) should be tested on both fuel options, unless they meet the criteria as a "mono" fueled vehicle as described above.

10. LPG Powered Vehicles

On these vehicles the hydrocarbons emitted are propane rather than hexane, so the HC reading obtained must be divided by the "propane/hexane equivalency factor" (PEF) marked on the gas analyser. For example:

An LPG vehicle gives a reading of 700 ppm.

The PEF marked on the machine is 0.48.

So the actual value is

$$\frac{700}{0.48} = 1458 \text{ (i.e. a fail).}$$

Some exhaust gas analysers have an automatic facility for doing this.

11. Vehicles That Require a Catalyst Test

a) Vehicles that are listed in the current edition of the "In Service Exhaust Emissions Standards for Road Vehicles" publication that are

- petrol fueled "Passenger Cars" having an effective date from 1 August 1992 - 31 July 1995 *see note below.
- petrol fueled other four or more wheeled vehicles having an effective date from 1 August 1994 - 31 July 1997 * see note.

NOTE: A catalyst test is not applicable if it can be demonstrated by the submission of vehicle specific evidence from the manufacturer, that confirms the date of manufacture of the vehicle and that it was not manufactured with a catalyst equipped emission system.

- b) All petrol fueled "Passenger Cars" having an effective date from 1 August 1995.
- c) All petrol fueled other four or more wheeled vehicles having an effective date from 1 August 1997.

d) All gas fueled vehicles having an effective date from 1 October 1999.

12. "Passenger Car" definition

A "Passenger Car" is a motor vehicle which

- is constructed or adapted for use for the carriage of passengers and is not a goods vehicle, and
- has no more than 5 seats (including occasional seats) in addition to the driver's seat, and
- has a maximum gross weight not exceeding 2500kg, and
- has 4 or more wheels.

Exhaust Emissions (Spark Ignition) - visual 18*

Application	Procedure and Standards	Reasons for Failure
<p>This inspection applies to all spark ignition engined vehicles to which this section applies (see para. 1 page 1).</p> <p>Vehicles fitted with modified engines: If an engine has been modified in any way, it still has to meet the exhaust emission requirements according to the "effective date" of the vehicle.</p> <p>The "Effective Date" used to determine the criteria applicable is:- the date of manufacture of the vehicle, except for an "Amateur Built" vehicle, a vehicle "Manufactured using parts of a registered vehicle" or a "Rebuilt vehicle" it shall be 1 January immediately preceding the date of manufacture of the vehicle's engine, if this is earlier.</p> <p>NOTE: For definitions of the above categories see Foreword item 9.</p> <p>Evidence of the date of manufacture could be for example</p> <ul style="list-style-type: none"> ▪ a copy of the donor vehicle registration document (where the engine was the original fitted to the vehicle). ▪ a letter from the manufacturer confirming the date of manufacture or the production period. <p>If the production period spans a critical emission boundary, the</p> <p style="text-align: right;">Cont'd ▼</p>	<p>A. All vehicles</p> <ol style="list-style-type: none"> 1. Raise the engine speed to around 2500rpm or half the maximum engine speed if this is lower. Hold this speed steady for 20 seconds to ensure that the inlet and exhaust system is properly purged. Allow the engine to return to idle and the emissions to stabilise. <ol style="list-style-type: none"> a. Assess the engine idle speed. b. Assess the smoke emitted from the tailpipe at idle. c. Rapidly increase the engine speed to around 2500rpm or half maximum engine speed if this is lower and assess the smoke emitted from the tailpipe. Allow the engine to return to idle. 	<p>A. All vehicles</p> <ol style="list-style-type: none"> 1. The engine <ol style="list-style-type: none"> a. is idling at a speed clearly above its normal idling speed b. emits dense blue or clearly visible black smoke for a continuous period of 5 seconds at idle c. emits excessive smoke or vapour of any colour during acceleration which would obscure the view of other road users.

18*

Exhaust Emissions (Spark Ignition) - visual (cont'd)

Application	Procedure and Standards	Reasons for Failure
<p>vehicle will be tested to the latter standard.</p> <p>If the “effective date” cannot be determined it will be assumed to be after 1 August 1997 in the case of a vehicle running on petrol, and after 1 October 1999 in the case of a vehicle running on gas, (i.e. catalyst emission test)</p> <p>NOTE: The onus is on the vehicle presenter to prove engine age.</p>		

DRAFT

Exhaust Emissions (Spark Ignition) 18*

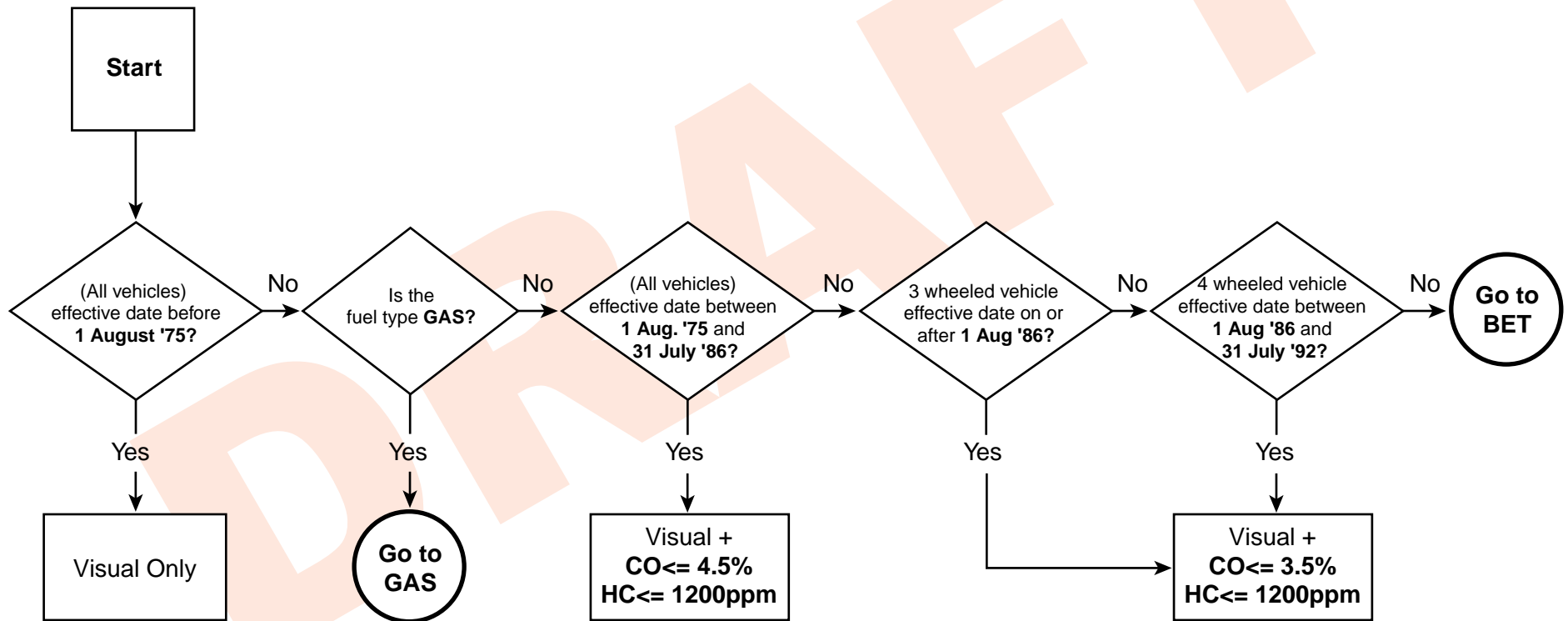

18*

Exhaust Emissions (Spark Ignition) cont'd

Application	Procedure and Standards	Reasons for Failure
<p>All vehicles fitted with a spark ignition engine to which this Section applies (see para. 1 page 1) requiring a non - catalyst test except</p> <ul style="list-style-type: none">a) a rotary piston engined vehicle having an effective date before 1 August 1987.b) a 2 stroke engined vehiclec) vehicles fuelled by CNG (Compressed Natural Gas) in respect of the requirement to check Hydrocarbons	<p>B. Vehicles having an effective date from 1 August 1975</p> <p>NOTE: When checking the exhaust emissions, the engine must be at its normal idle speed and normal operating temperature. Engine speed and temperature can be assessed either subjectively or by reference to manufacturer's or other reliable data.</p> <ul style="list-style-type: none">1. Check that the analyser probe can be inserted into the tailpipe.2. Use a suitable exhaust gas analyser to determine the proportions of carbon monoxide (CO) and hydrocarbons (HC) in the exhaust gas over a period of at least 5 seconds at idle. <p>NOTE: Any residual hydrocarbons (i.e. those indicated by the analyser when it is sampling only clean air) should be deducted from the HC reading obtained from the vehicle.</p> <p>NOTE: If a vehicle meets the CO requirement at its normal idling speed but fails the HC check, re-check the HC level at a high idle speed of 2000rpm. If the HC reading is then 1200ppm or less, the vehicle will meet both the CO and HC requirements.</p> <ul style="list-style-type: none">▪ The CO requirement must be met with the engine running at its normal (low) idling speed. Do not use a cold start/cold running mechanism to achieve a high idle speed, instead, apply light pressure to the throttle pedal.	<p>B. Vehicles having an effective date from 1 August 1975</p> <ul style="list-style-type: none">1. The emissions cannot be measured because a tailpipe accessory is fitted which prevents insertion of the analyser probe2. The exhaust gas contains<ul style="list-style-type: none">a. a carbon monoxide content exceeding the limit for a continuous period of 5 secondsb. a hydrocarbon content exceeding the limit for a continuous period of 5 seconds.

Exhaust Emissions (Spark Ignition) - BET 18*

Application	Procedure and Standards	Reasons for Failure
<p>1996 Specification Analysers</p> <p>All 1996 Specification analysers will prompt when to carry out specific operations, e.g. "run the engine at fast idle". You must follow these prompts closely. The method of inspection opposite is given for reference purposes only.</p> <p>Printouts and check sheets</p> <p>The 1996 specification analysers will produce two printouts. One printout must be retained ideally with the SVA20/SVA30 records and the other printout must be given to the vehicle presenter.</p> <p>Gas analyser probe</p> <p>It is important to ensure that the gas analyser probe is inserted as fully as possible into the exhaust pipe and is secure.</p>	<ol style="list-style-type: none"> 1. <ol style="list-style-type: none"> a. A suitable exhaust gas analyser will be needed to perform this inspection. Check that the analyser probe can be inserted into the tailpipe. b. Ensure that the analyser's daily leak check has been performed. 2. Vehicles having an Effective Date from 1 August 1992 onwards - Basic Emission Test (BET) <ol style="list-style-type: none"> a. Carry out the test using the flowchart. b. Ensure that the engine is hot by checking for example - temperature gauge, cooling fan cut-in or hot coolant hoses. If the engine is not at normal temperature raise the engine speed to between 2000 and 3000rpm and maintain this speed until normal temperature has been reached. c. Attach engine speed measuring device. It is permissible for the purposes of this check to use the vehicle tachometer. d. Ensure the engine is idling normally. e. Perform a HC hang-up check and ensure that HC<20ppm before continuing. Insert the analyser sample probe. f. Fast idle test: Raise the engine speed to a fast idle between 2500 and 3000rpm and hold steady. Note the readings for CO, HC and lambda, and record the results. g. Idle test: Allow the engine to idle. Note the CO reading and record the result. h. Remove analyser sample probe. 	<ol style="list-style-type: none"> 1. The emissions cannot be measured because a tailpipe accessory is fitted which prevents insertion of the analyser probe. 2. If the vehicle does not meet the BET limits go to CAT1 button. <p>NOTE: There is no reason for rejection for vehicles that do not meet the BET limits.</p>

18*

Exhaust Emissions (Spark Ignition) - BET (cont'd)

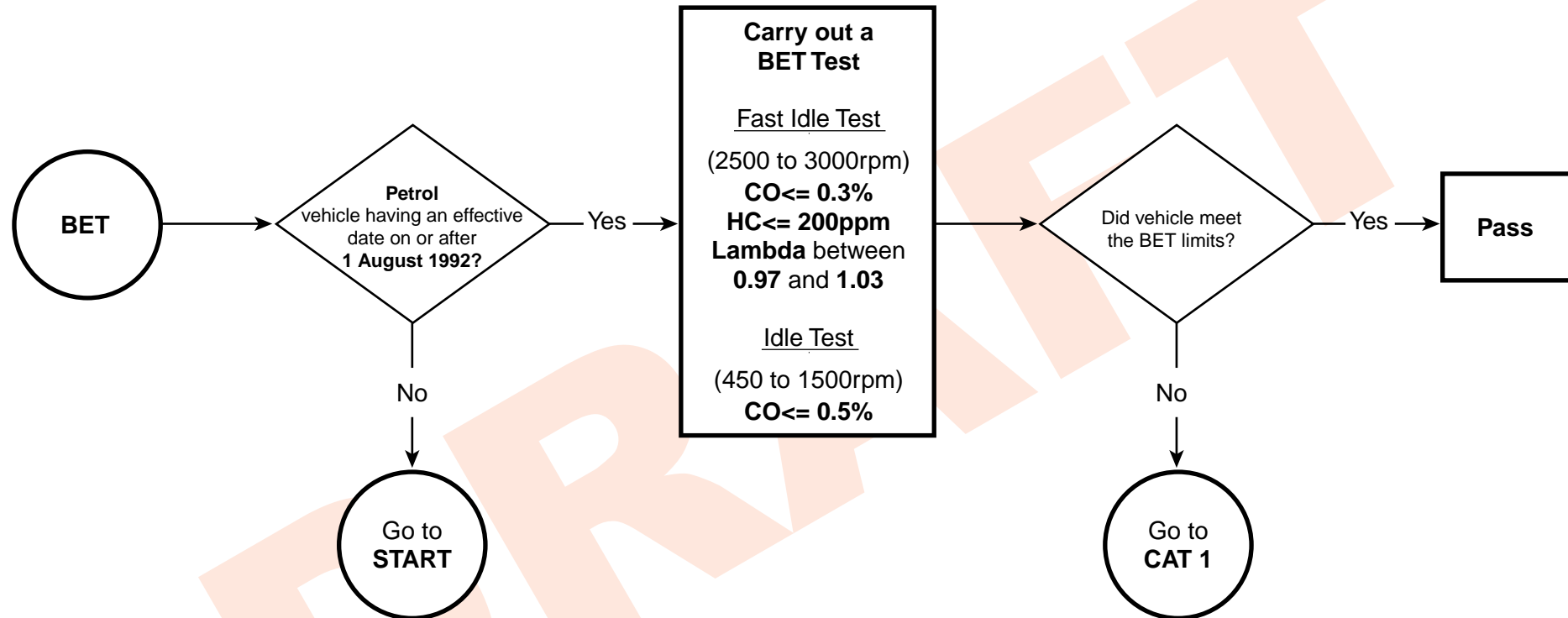

Notes for BET

1. Ensure that the engine is hot enough to test
e.g. temperature gauge, cooling fan cut-in or hot coolant hoses.
2. Ensure that the engine idle speed is normal.
3. For the purposes of this test an engine speed measuring device should be used.

Exhaust Emissions (Spark Ignition) - cat test 18*

Application	Procedure and Standards	Reasons for Failure
<p>All vehicles fitted with a spark ignition engine to which this Section applies (see para. 1 page 1) except</p> <ul style="list-style-type: none"> a) vehicles fueled by LPG or CNG (liquid petroleum gas or compressed natural gas) in respect of the requirement to check the value of lambda. b) vehicles fueled by CNG in respect of the requirement to check Hydrocarbons. c) vehicles fueled by LPG or CNG having an effective date <ul style="list-style-type: none"> ▪ in the case of a "passenger car" from 1 August 1992 - 30 September 1999 ▪ in the case of an other four or more wheeled vehicle from 1 August 1994 - 30 September 1999 to which the requirements apply when running on LPG/CNG as if the vehicle had an effective date of 1 August 1986 (i.e. non-catalyst test). d) vehicles that are listed in the current edition of the "In Service Exhaust Emission Standards for Road Vehicles" publication that are <ul style="list-style-type: none"> ▪ passenger cars having an effective date from 1 August 1992 - 31 July 1995 <p style="text-align: right;">Cont'd ▼</p>	<ul style="list-style-type: none"> 1. A suitable exhaust gas analyser will be needed to perform this inspection. Check that the analyser probe can be inserted into the tailpipe. 2. <ul style="list-style-type: none"> a. Ensure that the analyser's daily leak check has been performed. b. Identify the vehicle specific test limits using the flow charts. c. Connect the engine speed measuring device and insert the engine oil temperature measuring probe into the dipstick hole <p>NOTE: Engine speed and engine oil temperature must be measured whenever possible. If engine speed cannot be measured then the vehicle tachometer should be used if fitted. Otherwise, a subjective estimate should be made. If engine oil temperature cannot be measured, see note in paragraph "d" below</p> d. Engine pre-conditioning: Check the engine oil temperature. If it is below the minimum vehicle specific requirement, raise the engine speed to between 2000 and 3000rpm and maintain this speed until the minimum engine oil temperature has been reached. Remove <p style="text-align: right;">Cont'd ▼</p>	<ul style="list-style-type: none"> 1. The emissions cannot be measured because a tailpipe accessory is fitted which prevents insertion of the analyser probe. 2. <ul style="list-style-type: none"> a. The engine idle speed is clearly above the vehicle specific limit. <p>Note: If the engine speed is clearly above the vehicle specific limit and this can be easily adjusted, the presenter may be given the opportunity to adjust the setting.</p> b. In the 2nd fast idle test, one or more of the following exceeds the vehicle specific or default limits (as appropriate) continuously for the last 5 seconds of the 30 second countdown: <ul style="list-style-type: none"> - Carbon monoxide (CO) - Hydrocarbons (HC) - Lambda (λ) c. In the idle test, the following gas exceeds the vehicle specific or default limit (as appropriate) continuously for the last 5 seconds of the 30 second countdown: <ul style="list-style-type: none"> - Carbon monoxide (CO).

18*

Exhaust Emissions (Spark Ignition) - cat test (cont'd)

Application	Procedure and Standards	Reasons for Failure
<p>▪ other four or more wheeled vehicles having an effective date from 1 August 1994 - 31 July 1997</p> <p>where it can be demonstrated by the submission of vehicle specific documentary evidence from the manufacturer that confirms the date of manufacture of the vehicle and that it was not manufactured with a catalyst equipped emission system.</p> <p>When to do the test</p> <p>It is recommended that the extended test is carried out as soon as possible after the BET. This allows the test to be carried out on a fully warmed up engine.</p> <p>Printouts and check sheets</p> <p>The 1996 specification analysers will produce two printouts. One printout must be retained ideally with the SVA20/SVA30 records and the other printout must be given to the vehicle presenter.</p> <p>Working environment</p> <p>To prevent the build up of fumes, the test should be carried out in a well ventilated area.</p> <p>Gas analyser probe</p> <p>It is important to ensure that the gas analyser probe is inserted as fully as possible into the exhaust tail-pipe and is secure.</p> <p style="text-align: right;">Cont'd ▼</p>	<p>temperature measuring probe and replace dipstick</p> <p>NOTE: Where, in exceptional circumstances, the engine oil temperature cannot be measured (e.g. in the case of a dry sump engine), check one of the following; temperature gauge shows warm engine, cooling fan has cut in or coolant pipes are hot.</p> <p>e. Perform a HC hang-up check and ensure that HC<20ppm before continuing. Insert the analyser sample probe</p> <p>f. 1st Fast Idle Test: Raise the engine speed to the vehicle specific fast idle speed and maintain for 30 seconds. If the engine speed drifts outside the fast idle speed range, begin the 30 second countdown again. During the last 5 seconds note the readings for CO, HC and lambda, and record the results</p> <p>g. If the vehicle has passed the first fast idle test, then go to paragraph "j", otherwise go to paragraph "h"</p> <p>h. Additional engine pre-conditioning: Run the engine between 2000-3000rpm for 3 minutes or until all the emissions are within limits. If the engine speed goes outside the fast idle range, then freeze the countdown until the engine speed is within range once again</p> <p>i. 2nd Fast Idle Test: Repeat the procedure as laid down in paragraph "f", then go to paragraph "j"</p> <p>j. Catalyst stabilisation: Raise the engine speed to the vehicle specific fast idle speed and maintain for 30 seconds. If the engine speed drifts outside the fast idle speed range then begin the 30 second countdown again</p> <p style="text-align: right;">Cont'd ▼</p>	

Exhaust Emissions (Spark Ignition) - cat test 18*

Application	Procedure and Standards	Reasons for Failure
<p>Cosmetic engine covers</p> <p>Where engine speed can only be measured by the removal of a cosmetic engine cover, the engine speed must be measured if the cover can be easily un-clipped. Otherwise, engine speed measurement may be by-passed.</p>	<ul style="list-style-type: none">k. Idle test: Allow the engine to idle during a 30 second countdown. During the last 5 seconds, note the CO reading and record the resultl. Remove analyser sample probe and engine speed measuring device.	

DRAFT

18*

Exhaust Emissions (Spark Ignition) cont'd

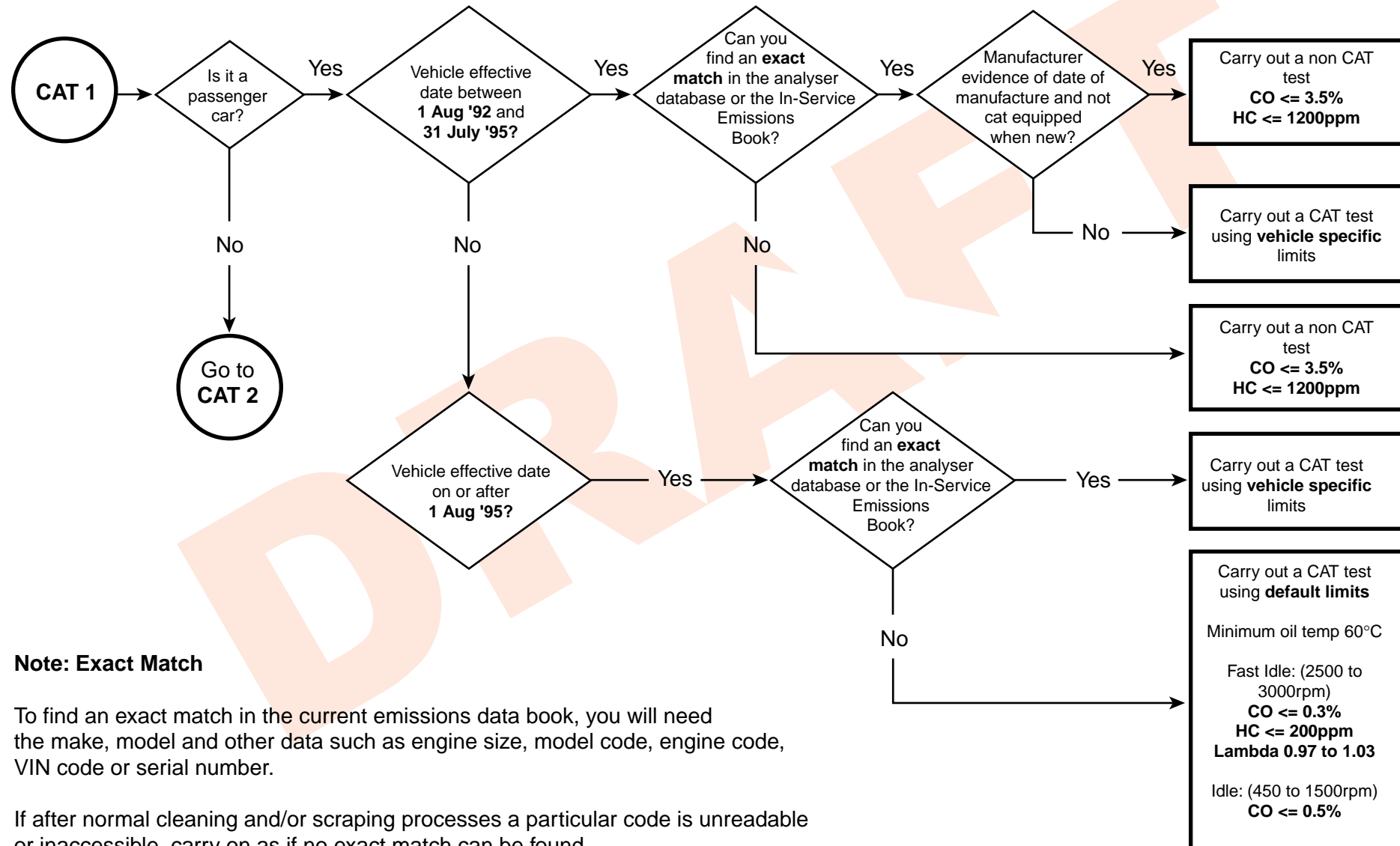

Exhaust Emissions (Spark Ignition) cont'd 18*

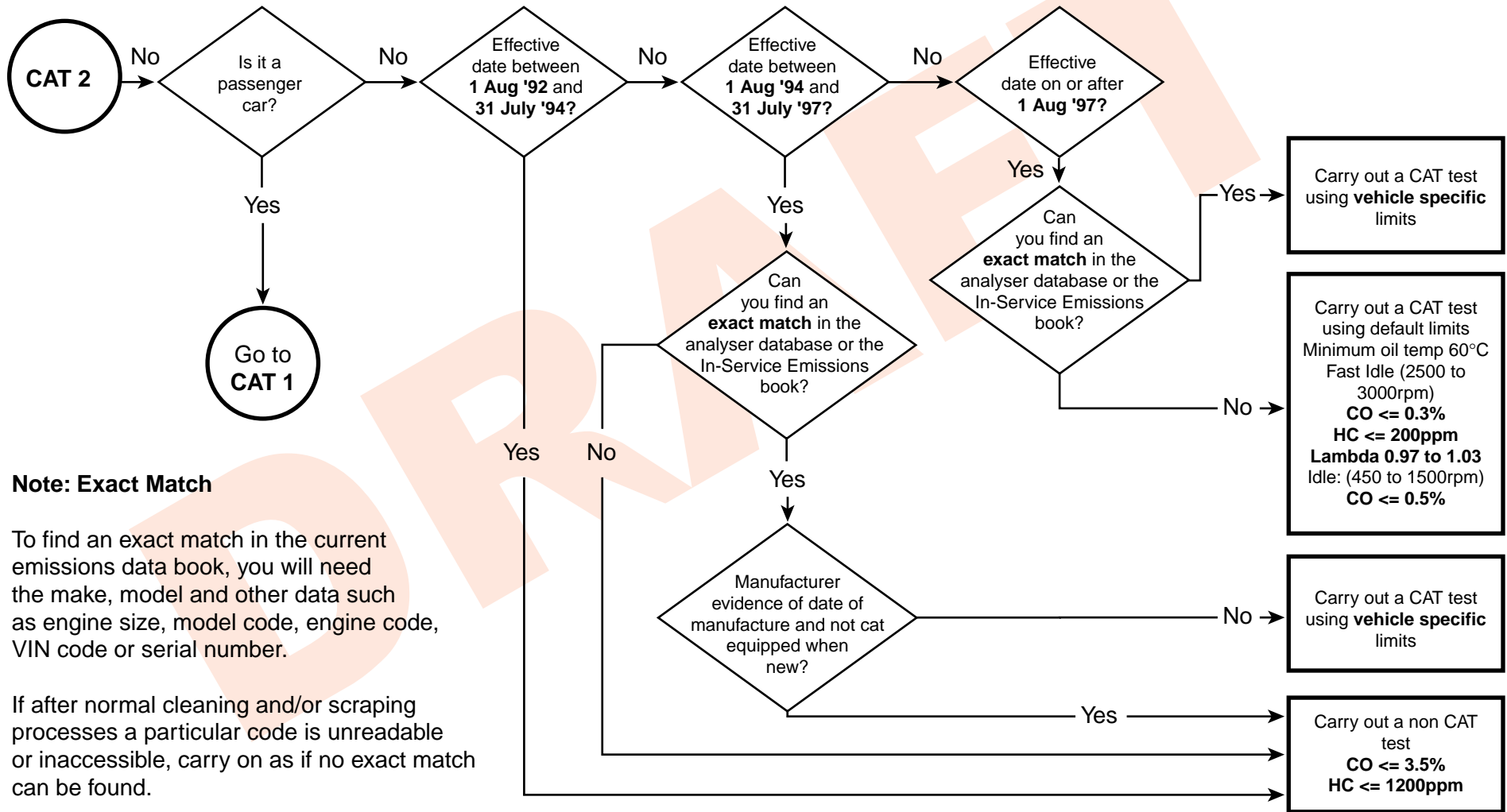

Note: Exact Match

To find an exact match in the current emissions data book, you will need the make, model and other data such as engine size, model code, engine code, VIN code or serial number.

If after normal cleaning and/or scraping processes a particular code is unreadable or inaccessible, carry on as if no exact match can be found.

18*

Exhaust Emissions (Spark Ignition) - Gas

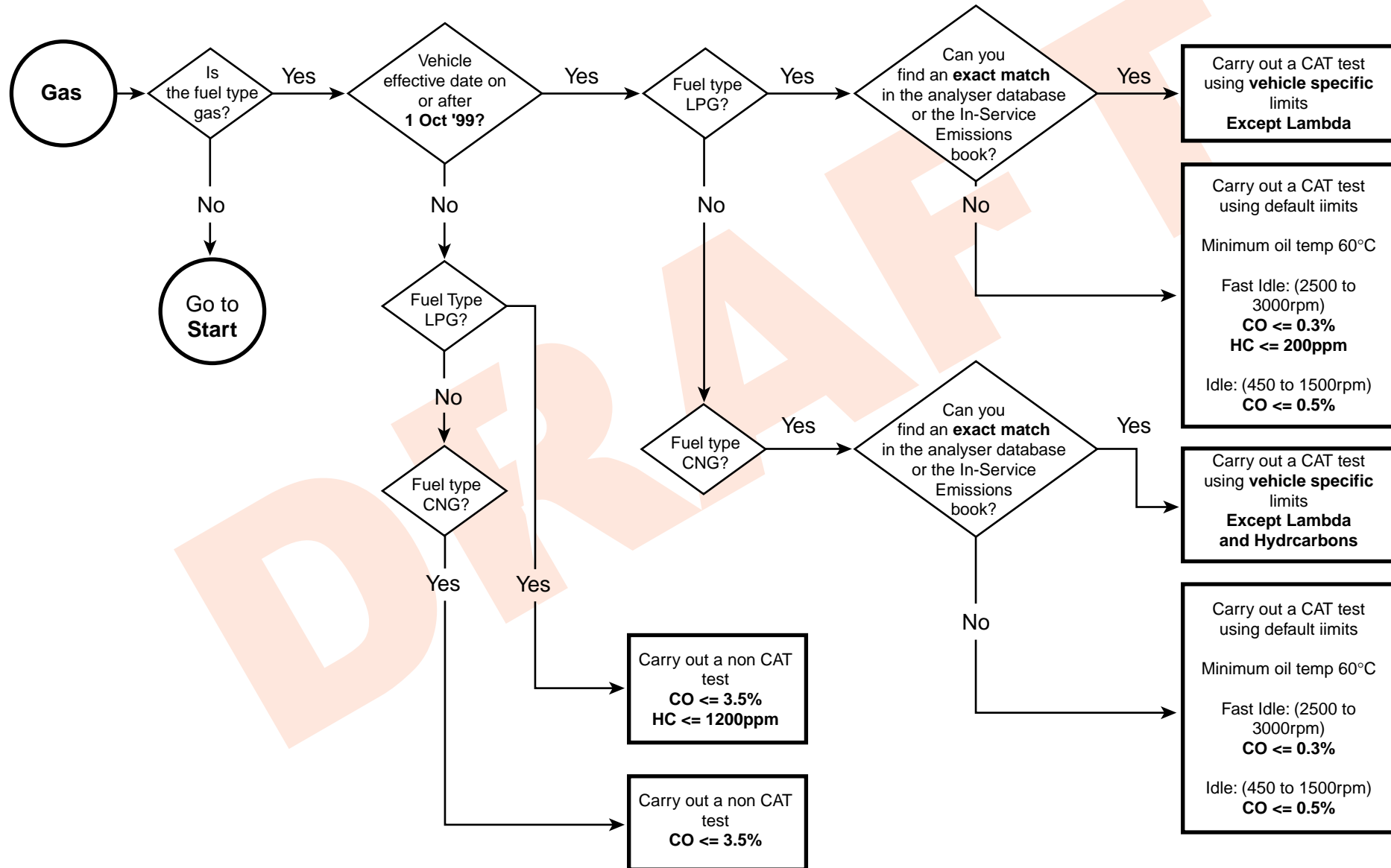

Exhaust Emissions (Diesel) 19*

Application	Procedure and Standards	Reasons for Failure
<p>This inspection applies to all vehicles with compression ignition (diesel) engines having an “effective date” on or after 1 August 1979.</p> <p>“Effective Date”</p> <p>The “effective date” used to determine the criteria applicable is - the date of manufacture of the vehicle, except for an “Amateur Built” vehicle, or a “Vehicle manufactured using parts of a registered vehicle” where it shall be 1 January immediately preceding the date of manufacture of the vehicle’s engine if this is earlier.</p> <p>If the “effective date” cannot be determined, it must be assumed to be on or after 1 August 1979.</p> <p>Reasons for not carrying out a smoke test.</p> <p>Do not carry out a smoke test if the engine is not in a safe condition to do so. This will involve questioning the vehicle presenter and a brief examination of the engine condition. A smoke test must not be carried out if the oil temperature is below 60°C. The reason for not conducting a smoke test must be clearly recorded on the Notification of Refusal (SVA30).</p> <p style="text-align: right;">Cont'd ▼</p>	<ol style="list-style-type: none"> 1. Where possible check that: <ul style="list-style-type: none"> ▪ there is sufficient oil in the engine, ▪ the oil pressure is not too low, ▪ the camshaft belt is in a satisfactory condition, ▪ there is no abnormal engine noise, ▪ the governor has not been tampered with, ▪ the engine is at normal operating temperature, (see Application column). a. If appropriate, remove oil temperature probe. Raise the engine speed to around 2500rpm, or half the maximum engine speed if this is lower and hold for 30 seconds to fully purge the inlet and exhaust system. b. Raise the engine speed slowly to maximum to check the operation of the governor. Once the engine speed has stabilised or if it becomes clear that the governor is not working, release the pedal, return to idle and stop the engine. c. Prompt the meter to carry out a zero check . d. Check that the smoke meter probe can be inserted into the tailpipe. e. Insert the probe fully and securely, in line with the gas flow. Restart the engine. <p style="text-align: right;">Cont'd ▼</p>	<ol style="list-style-type: none"> 1. <ol style="list-style-type: none"> a. The emissions cannot be measured because a tailpipe accessory is fitted or a deliberate modification has been made which prevents insertion of the smoke meter probe. <p style="text-align: right;">Cont'd ▼</p>

19*

Exhaust Emissions (Diesel) cont'd

Application	Procedure and Standards	Reasons for Failure
<p>Automatic transmission</p> <p>When testing vehicles fitted with automatic transmission care must be taken to avoid overheating the transmission system.</p> <p>Do not carry out unnecessary engine acceleration or prolonged high revving of the engine. Reference to vehicle manufacturers instructions may be necessary.</p>	<p>Fast Pass</p> <ul style="list-style-type: none">f. Following the meter prompts, depress the accelerator pedal quickly and continuously but not violently, to reach full fuel position in less than 1 second.g. Hold it there until a release prompt is given, then immediately release the pedal. Allow the engine, and any turbocharger fitted, to return to idle speed.h. At the end of the 1st acceleration read the smoke level displayed on the meter. If it is at or below 1.50m¹ the vehicle has passed this part of the test and a pass result will be displayed on the meter. Go to Procedure and Standards "m."	<p>NOTE: There is no reason for rejection for vehicles that do not meet the fast pass criteria.</p>

Cont'd ▼

Cont'd ▼

Exhaust Emissions (Diesel) cont'd 19*

Application	Procedure and Standards	Reasons for Failure
	<ul style="list-style-type: none"> i. If the 1st acceleration smoke level is greater than 1.50m^{-1} carry out two further accelerations following the meter prompts. j. At the end of the 3rd acceleration, read the mean smoke level displayed on the meter. If it is at or below the appropriate limit, the vehicle has passed this part of the test and a pass result will be displayed on the meter. Go to Procedure and Standards "m." k. If the mean smoke level is too high, carry out further accelerations up to a maximum of 6 in total. l. After each acceleration, check the mean reading. This part of the test is complete when either: <ul style="list-style-type: none"> ▪ the mean of any 3 consecutive smoke readings is at or below the appropriate limit, or ▪ six accelerations have been performed. m. Assess whether the smoke emitted from the exhaust, regardless of measured density, is likely to obscure the vision of other road users. 	<ul style="list-style-type: none"> b. After 6 free accelerations, the mean of the last 3 smoke levels is: <ul style="list-style-type: none"> i for a non-turbocharged engine, more than 2.50m^{-1} ii for a turbocharged engine, more than 3.00m^{-1}. c. Exhaust emits excessive smoke or vapour of any colour to an extent likely to obscure the vision of other road users <p>NOTE: The criterion is density and not volume of smoke. The description 'dense smoke' includes smoke or vapour which largely obscures vision.</p>

Speedometer 20

Application	Procedure and Standards	Reasons for Failure
<p>All vehicles having a maximum speed exceeding 25mph except Goods vehicles.</p>	<ol style="list-style-type: none"> 1. Check that a speedometer is fitted and is capable of indicating the vehicle speed in miles per hour (mph) at uniform intervals not exceeding 20mph for all speeds up to the maximum design speed of the vehicle. <p>NOTE 1: Both the increments and units of measurement eg mph, m/h must be displayed.</p> <p>NOTE 2: It is acceptable if the maximum speed of the vehicle is indicated by the last increment on the speedometer which must not be more than 19mph beyond the last 20mph increment.</p> <p>NOTE 3: It is acceptable for the speedometer needle "rest" position to be between the zero position and first marked increment.</p> 2. Check that the speedometer is capable of being read at all times of the day or night, eg by illumination. <p>NOTE: Temporary obstruction by the steering wheel is acceptable.</p> 	<ol style="list-style-type: none"> 1. A speedometer <ul style="list-style-type: none"> ▪ not fitted ▪ inoperative ▪ does not indicate the speed in mph ▪ indicates speed at intervals exceeding 20mph ▪ not capable of recording speeds up to the vehicle maximum design speed. 2. A speedometer not capable of being read at all times.

Cont'd ▼

Cont'd ▼

20 Speedometer (cont'd)

Application	Procedure and Standards	Reasons for Failure																		
	<p>3. Where the accuracy of the device is in question, and with the vehicle positioned on, or fitted with a speed measurement device, operated to the manufacturer's instructions, drive the vehicle at a stable speedometer indicated speed of 35mph and note the true speed.</p> <p>Compare the indicated speed recorded with the true speed. Repeat the test at various speeds, as necessary to confirm compliance.</p> <p>The speedometer must not indicate a speed less than the true speed.</p> <p>At speedometer indicated speeds between 35mph and 70mph (or the maximum design speed if lower) the true speed must not be less than that shown in the following table.</p> <table border="1" data-bbox="799 823 1209 1197"> <thead> <tr> <th>Indicated Speed (mph)</th> <th>Min True Speed (mph)</th> </tr> </thead> <tbody> <tr><td>35</td><td>26</td></tr> <tr><td>40</td><td>30</td></tr> <tr><td>45</td><td>35</td></tr> <tr><td>50</td><td>39</td></tr> <tr><td>55</td><td>44</td></tr> <tr><td>60</td><td>48</td></tr> <tr><td>65</td><td>53</td></tr> <tr><td>70</td><td>57</td></tr> </tbody> </table> <p>NOTE: Where the accuracy of the speedometer cannot be measured on the equipment available, the vehicle presenter may be required to provide documentary evidence of compliance.</p>	Indicated Speed (mph)	Min True Speed (mph)	35	26	40	30	45	35	50	39	55	44	60	48	65	53	70	57	<p>3. A speedometer indicates a speed</p> <ul style="list-style-type: none"> ▪ which is less than the true speed of the vehicle ▪ in excess of the true speed plus the permitted tolerance. <p>NOTE: If for a given indicated speed the true speed is less than the minimum requirement shown in the table this confirms that the recorded speed is in excess of the true speed by more than the permitted tolerance calculated by the equation</p> $\frac{\text{true speed}}{10} + 6.25\text{mph}$
Indicated Speed (mph)	Min True Speed (mph)																			
35	26																			
40	30																			
45	35																			
50	39																			
55	44																			
60	48																			
65	53																			
70	57																			

Manufacturer's Plate 22*

Application	Procedure and Standards	Reasons for Failure
Goods vehicles only	<ol style="list-style-type: none"> 1. Check the vehicle is fitted with a "manufacturer's" plate securely attached in a conspicuous and readily accessible position that displays the <ul style="list-style-type: none"> ▪ manufacturer's name ▪ vehicle identification (chassis) number ▪ maximum permitted laden weight for each axle ▪ maximum permitted laden weight of the vehicle ▪ maximum permitted laden weight for the combination (if equipped to tow a trailer). 2. Check the plate <ul style="list-style-type: none"> ▪ is of a durable material ▪ details are of an indelible marking ▪ VIN characters are not less than 4mm in height. <p>NOTE: In the case of a vehicle that at the time of manufacture complied with the FMVSS requirements and which is fitted with a plate produced by the manufacturer the VIN characters may be less than 4mm in height.</p> 3. Check <ul style="list-style-type: none"> ▪ in the case of a vehicle not subject to "down-plating" that the vehicle is accompanied by evidence that the weights displayed are those allocated by the manufacturer (see note 1) ▪ in the case of a "down-plated" vehicle that the vehicle is accompanied by evidence that the axle weights displayed are those allocated by the manufacturer, (see note 2) and ▪ in either case, the design gross weight displayed on the manufacturers plate does not exceed 3500kg <p style="text-align: right;">Cont'd ▼</p>	<ol style="list-style-type: none"> 1. A Manufacturer's plate <ul style="list-style-type: none"> ▪ not fitted ▪ not in a suitable position ▪ insecure ▪ not displaying the required details. 2. A plate <ul style="list-style-type: none"> ▪ not of a durable material ▪ not indelibly marked ▪ having a VIN character less than 4mm in height. 3. The vehicle <ul style="list-style-type: none"> ▪ was not accompanied by evidence that the design weights displayed are those allocated by the manufacturer ▪ design gross weight displayed exceeds 3500kg ▪ is not fitted with power braking to operate the trailer brakes and the displayed maximum combination weight exceeds the vehicle design weight + 3500kg (or the manufacturer's combination design limit).

22* Manufacturer's Plate (cont'd)

Application	Procedure and Standards	Reasons for Failure
	<ul style="list-style-type: none"> ▪ in the case of a “down-plated” vehicle with no power braking to operate trailer brakes that the maximum permitted combination weight displayed is not more than the vehicle design weight + 3500kg. (subject to manufacturer’s design limit). <p>NOTE 1: This requirement will be deemed to have been met if the plate displaying the weights was fitted by the manufacturer at the time of manufacture.</p> <p>NOTE 2: Where the vehicle is subject to voluntary down-plating to a weight less than the manufacturer’s design weight evidence of the original design weights must be provided.</p> <p>NOTE 3: Where the vehicle is subject to voluntary down-plating,</p> <ul style="list-style-type: none"> ▪ the manufacturer’s original design gross weight must not exceed 5500kg ▪ the kerbside weight must not exceed 3425kg ▪ the vehicle must be of the same “family of types” as a vehicle previously issued a Minister’s Approval Certificate <p>NOTE: “Family of Types” means vehicles that do not differ in the following respects;-</p> <ul style="list-style-type: none"> ▪ manufacturer ▪ chassis/floor pan (obvious or fundamental differences) ▪ power plant (Internal combustion/Electric/Hybrid) 	

Glossary of Terms

Air Bag

A flexible bag fitted to a vehicle designed to be filled with gas under pressure in order to protect the driver or a front seat passenger in the event of a collision involving the front of the vehicle.

Blunted Edge

An edge not likely to cause injury whatever the circumstances under finger/thumb pressure. (contact is not likely to puncture the skin).

Body Platform

The area resulting from the vertical projection of the complete body onto a horizontal surface; and for the purposes of this definition "complete body" means all parts of the bodywork and chassis, including any separate wheel guards but not including running gear such as wheels, axles, suspension, brakes and steering.

Brake Efficiency

Maximum total brake force expressed as a percentage of maximum gross weight.

CNG

Compressed Natural Gas.

Convertible Car

A vehicle where, in certain configurations, there is no rigid part of the vehicle body above the belt line with the exception of the front roof supports and/or the roll-over bars and/or the seat belt anchorage points.

Date of Manufacture

In the case of an Amateur Built Vehicle is, unless otherwise stated in the regulations or Inspection Manual:-

- the date on which the vehicle is presented for examination; or
- a date prior to the date the vehicle is presented for examination if there is conclusive evidence the vehicle was

completed and included all the parts which it needs to comply with the prescribed requirements and was in such a condition as to be acceptable to test on that date.

Designated Seating Position

A position where there is a seat designated for normal use while the vehicle is travelling on a road.

Disabled Persons Belt

A seat belt which has been specially designed or adapted for use by an adult or young person suffering from some physical defect or disability and which is intended for use solely by such a person.

External Surface

The outward facing surface of the vehicle at any height from the floor line up to a height of 2m from the horizontal surface on which the vehicle is standing.

Extreme Outer Edge

In relation to the side of a vehicle, the vertical plane parallel with the longitudinal axis of the vehicle and coinciding with its lateral outer edge, disregard the projection of

- a. distortion of any tyre due to the weight of the vehicle
- b. connections for tyre pressure gauges
- c. anti-skid devices mounted on the wheels
- d. rear view mirrors
- e. lamps and reflectors
- f. customs seals and devices for securing and protecting such seals
- g. special equipment
- h. in respect of Section 13 (Exterior Projections) only; windows, handles,

hinges, push buttons and fuel tank filler caps.

NOTE: In respect of item 'g', "Special Equipment" is – a movable platform fitted to a vehicle; the apparatus for moving the platform and any jacks fitted to the vehicle for stabilising it while the platform is moving.

Hard Parts

Parts made of a material of hardness exceeding 60 shore A. (Item 13)

Harness Belt

Means an adult belt which is a harness belt comprising a lap belt and shoulder straps.

Ignition Switch

A key operated switch normally used to start the engine.

In Running Order

In relation to the vehicle weight, means

- with all fluids (such as oils and engine coolant) necessary for the vehicle to be driven, the fuel tanks full, a spare wheel and tool kit
- carrying a driver weighing 68kg but no other passenger or load.

Insecure

A component or its fixing is, due to its design or a construction feature, not completely attached to the vehicle structure or to another associated component as intended.

Kerbside Weight

The weight of the vehicle with no driver or passengers, a full fuel tank, an adequate supply of the necessary oils, water, fluids etc and no load other than tools and equipment normally carried.

Glossary of Terms

Lambda

The ratio by mass of air to petrol vapour in the mixture entering the combustion chamber, divided by 14.7.

Lap Belt

A seat belt which passes across the front of the wearer's pelvic region and which is designed for use by an adult.

Lateral Brake Distribution

In relation to an axle, means the ratio (expressed as a percentage) of the lower to the higher of the braking forces transmitted by the tyres to the road surface for two wheels, on opposite sides of the vehicle on the same axle.

Longitudinal Brake Distribution

The ratio of the braking forces transmitted by the tyres to the road surface through the front and rear wheels respectively when the vehicle is in running order and being braked on a level surface.

Longitudinal Plane

A vertical plane parallel to the longitudinal axis of a vehicle.

LPG

Liquid Petroleum Gas.

Manufacturer's Plate

A piece of durable material eg metal or plastic that is likely to last the life of the vehicle and which is permanently marked with the required markings.

Power Braking

A system that requires the use of stored energy to operate.

Production Vehicle

A vehicle of a make, model and type mass produced by the vehicle manufacturer.

Rigid Material

A material which has a hardness of no less than 50 shore A.

Rotary Piston Engine

An engine in which the torque is provided by means of one or more rotary pistons and not by any reciprocating pistons and which is deemed to be a four stroke engine.

Seat Displacement Device

A device to permit forward tipping of a seat or the back rest to fold down.

Servo Assisted

A system where the muscular energy of the driver is supplemented by another energy source.

Side Screen

An item of glazing wholly or partly on either side of the driver's seat that does not slide or move relative to the vehicle or any of its parts (including glazing) in a manner likely to cause abrasion to any glazing surface.